

4.32 H

automotive lift date: 8/98

manual date: 25.11.99

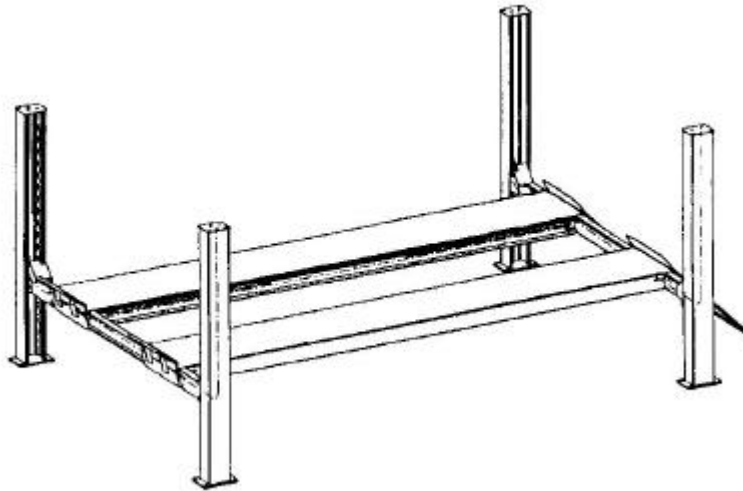

Operating Instruction and Documentation

serial number:.....

Retailer address / phone



Nußbaum
HEBETECHNIK

Contents

Foreword.....	3
Record of installation.....	5
Record of handing over.....	6
1. Introduction.....	7
1.1 Installation and check of the automotive lift.....	7
1.2 Information of Warning.....	7
2. Master of the document.....	8
2.1 Lift-manufacturer.....	8
2.2 Application.....	8
2.3 Changes at the construction.....	8
2.4 Displacement of the automotive-lift.....	8
2.5 CE-certificate/attestation of conformity.....	9
3. Technische Information.....	10
3.1 Technical ratings.....	10
3.2 Safety devices.....	10
3.3 Datasheet.....	11
3.4 Foundationplan.....	12
3.5 Electrical diagram	13
3.6 Hydraulic diagram	14
4. Safety regulations.....	15
5. Operating instructions.....	15
5.1 Lifting the vehicle with the automotive lift.....	15
5.2 Lowering the vehicle with the automotive lift.....	16
5.3 Lowering the automotive lift in the ratchet strip.....	17
5.4 Raise the automotive lift out of the ratchet strip.....	17
5.5 Driving on a obstacle.....	17
6. Troubleshooting.....	18
6.1 Emergency lowering in case of power failure or defective valve.....	18
7. Maintenance.....	19
7.1 Inspection and Maintenance of Nussbaum lifts.....	20
7.2 Cleaning the automotive-lift.....	21
8. Security check.....	22
9. Installation and Initiation.....	22
9.1 Regulations for the installation.....	22
9.2 Erection and doweling of the lift.....	23
9.3 Adjusting the rail.....	25
9.4 Initiation.....	25
9.5 Changing the installation place.....	26

Appendix

Position of the columns.....	27
Connections of the hydraulic tubes.....	28
Selection of Dowels.....	29
Document "First security check before Installation".....	31
Document "Regular security check".....	32
Document "Extraordinary security check".....	40

Foreword

Nußbaum-Lifts are a result of long-standing experiences.

The high quality and the superior concept guarantee them reliability, a long lift time and the economic business.

To avoid unnecessary damages and dangers, read the operating instruction attentive and observe the contents.

Another or the described purpose going out use is not valid when not as agreed.

This is valid particularly for climb and go.

Company Nußbaum is not liable for damages arising from this. The user carries the risk alone.

For the use belonged:

- to observe all the notice in the operating instruction and
- the following of the inspection and maintenance work and the prescribed tests.
- The instruction for use have to be observed by all persons working with the lift.
- Especially the chapter "Safety/accident Prevention" has to be observed.
- In addition to the safety remarks of the instructions for use the regulations and instructions being valid at the place of operation have to be considered.

Obligations of the operator:

The operator is obliged to allow only those persons complying to the following requirement to work at the unit

- being well acquainted with the basic regulations concerning labour safety and accident prevention and being trained to operate the unit.
- having read and understood the chapter concerning safety and warning instructions and confirmed that by their signature.

Dangers when operating with the lift:

The Nußbaum-Lifts are designed and built according to technical standard and the approved regulations for technical security. Yet, danger for body and life of the operator may turn up when using the lift inexpertly.

The lift must only be operated :

- for its appropriate use
- in unobjectionable condition concerning technical security.

Organising requirements

- The instructions for use are constantly to be kept at the place of operation being at hand at any time.
- In addition to the instructions for use rules pertaining to other regulations i.e. accident prevention and environmental rules are to be observed and directed.
- Safety- and danger alert operation of personal is occasionally and by observing the instructions for use to be controlled.
- As far as required and ordered by regulations personal protective equipment is to be used
- All safety- and danger-hints at the lift are to be observed!
- Spare parts must comply with technical requirements laid down by the manufacturer. This is only warranted with original parts.
Consider time intervals given or fixed in instructions for use for repeated tests/inspections.

Maintenanceworks, remedy of faults and disposal

- Fixed Adjusting-, maintenance- and inspectionworks and time intervals including Details for exchange of parts/part components as mentioned in the instructions for use are to be adhered.
These works must only be carried out by expert personal.
- After maintenance- and repair works loose screw connections must always be firmly tightend!



Filling out and undersigned and copying this sheet and send the original to the lift manufacturer. The copy remains in the Manual.

Otto Nußbaum Hebetechnik GmbH & Co.KG

Korker Strasse. 24

77694 Kehl-Bodersweier

Germany

Record of installation

The automotive lift 4.32 H with the

serial number:..... was installed on:.....

at the firm:..... at:.....

the safety was checked and the lift was started.

The installation was effected from the operating authority/competent (please delete as applicable).

The safety of the automotive lift was checked from the competent before the initial operation.

The operating authority attest the installation of the automotive lift, the competent attest the correct initial operation.

.....
date name of the operating authority signature of the operating authority

.....
date name of the competent person signature of the competent person

Your customer service is the company:.....

.....

automotive lift date: 898 manual date: 25.11.99

Record of handing over

The automotive lift 4.32 H with the

serial number:..... was installed on:.....

at the firm:..... at:.....

the safety was checked and the lift was started.

The persons below were introduced after the installation of the automotive lift. The introduction was carried out from an erector of the lift-manufacturer or from a franchised dealer (competent person).

.....
date	name	signature

.....
date	name	signature

.....
date	name	signature

.....
date	name	signature

.....
date	name	signature

.....
date	name	signature

.....
date	name of competent	signature of the competent

Your customer service is the company:.....

.....

1. Introduction

The document "Operating Instructions and Documentation" contains important information about installation, operation and maintenance of the lift.

To furnish proof of **installation of the automotive lift** the form "Record of Installation" must be signed and returned to the manufacturer.

To furnish proof of the singular, felt this documentation contains forms. The forms should be used to document the checks. They should not be removed from this documentation.

Every **Changes to the construction and displacement** of the automotive lift must be registered in the "Master document" of the lift.

1.1 Installation and check of the automotive lift

Only specialist staff is allowed to do work concerning safety and to do the safety checks of the lift. They are called experts and competent person in this document.

Experts are persons (for example self-employed engineers, experts) which have received instruction and have experience to check and to test automotive lifts. They know the relevant labour and accidents prevention regulations.

Competent person are persons who have acquired adequate knowledge and experience with automotive lifts. They took part in training from the lift-manufacturer (servicing technicians of the manufacturer or dealer, are competent)

1.2 Information of Warning

To show danger and to show important information the three symbols below are used. Pay attention to those passages, which are marked with these symbols



Danger! This sign indicates danger to life. Inexpert handling of the described operation may be dangerous to life.



Caution! This sign cautions against possible damage to the automotive lift or other material defects in case of inexpert handling.



Attention! This sign indicates for an important function or other important notes.

2. Master document of the automotive lift

2.1 Lift –manufacturer Otto Nussbaum Hebeteknik GmbH & Co. KG
Korker Straße 24
D-77694 Kehl-Bodersweier

2.2 Application

The automotive lift **4.32 H** is a lifting mechanism for lifting motor vehicles with a laden weight of up to 3200 kg. The max. load distribution is 2:1 in or against drive-on direction. The automotive lift is only designed for servicing vehicles. It is not allowed to carry persons with the lift.

It's not allowed to install the standard-automotive lift in a hazardous location or washing bays.

2.3 Changes at the construction

Changes at the construction, expert checking, resumption of work (date, kind of change, signature of the expert)

.....
.....
.....
.....

name, address of the expert

.....
place, date

.....
signature of the expert

2.4 Displacement of the automotive-lift

Displacement of the automotive-lift, expert checking, resumption of work (date, kind of change, signature of the competent)

.....
.....

name, address of the competent

.....
place, date

.....
signature of the competent

2.5 CE-certificate/attestation of conformity

The automotive lift 4.32 H with the serial number.....

is in accordance with the tested lift (CE-Certificate-number 04 205-2498/98).

.....
place,date

.....
company stamp, signature

ZERTIFIKAT
CERTIFICATE



Registrier-Nr./Registered No.:
04 205-2498/98

EG-Baumusterprüfbescheinigung gemäß Anhang VI der EG-Richtlinie 98/37/EG
EC-type approval according to annex VI of the EC-Directive 98/37/EC

Zeichen des Auftraggebers Reference of applicant	Auftragsdatum Date of application	Aktenzeichen File reference	Prüfbericht Nr. Test-report No.	Ausstellungsdatum Date of issue	Gültigkeits- Expiry date
Hr. Müller	18.05.1998	2.4-985/98	2496/98 u. 2497/98	14.09.2000	14.09.2005

Hiermit wird bestätigt, daß das nachfolgend genannte Produkt den grundlegenden Anforderungen der Richtlinie des Rates vom 22.06.98 zur Angleichung der Rechts- und Verwaltungsvorschriften der Mitgliedstaaten über Maschinen entspricht.
We hereby certify that the product mentioned below meets the basic requirements of the council directive dated 22.06.98 on the approximation of the laws, regulations and administrative provisions of the member states relating to machinery.



Antragsteller
Applicant: Otto Nußbaum GmbH & Co. KG
Korker Straße 24, D-77695 Kehl

Fertigungsstätte: s.o.
Manufacturing plant:

Produktbeschreibung: Kfz.-Hebebühne (car lifter): 4.32 H
Product description: Nutzlast (nominal load): 3200 kg
max. Hubhöhe (nominal height): 1850 mm

Zertifizierungsstelle des RWTÜV e.V.
für Gerätesicherheit, Aufzüge
und Medizintechnik, notifiziert bei der
EG-Kommission unter Nr. 0044

Rheinisch-Westfälischer
Technischer Überwachungs-
Verein e.V., Sitz: Essen
Langemarkstraße 20
D-45141 Essen
Postfach 10 32 61
D-45022 Essen
Telephone +49(0)1 8 25-0
Telefax +49(0)1 8 25-33 56

3. Technical Information

3.1 Technical ratings

Capacity automotive lift:	3200 kg
Load distribution:	2:1 in or against drive-on direction
Lifting time automotive lift:	approx. 22 sec.
Lowering time automotive lift:	approx. 13 sec.
Max. height of lifting:	max. 1960mm
Line voltage:	3 x 400 Volt , 50Hz
Driving voltage	24 Volt
Power rating:	3 kW
Motor speed:	2800 rotation/min
Pump capacity:	3 ccm/revolution
Hydraulic pressure:	approx. 245 bar
Pressure relief valve:	approx. 300 bar
Oiltank:	approx. 14 litre - viscosity 32 cst.
Sound level:	≤ 75 dBA
Connection by customer (standard)	3~/N+PE, 400V, 50 Hz with fuse 16A T (Pay attention to the tension of your state)

3.2 Safety device

1. safety ratchets
safety device against unintentional lowering.
2. safety switch
when the ropes are flabby or torn, the lift switched off.
3. pressure relief valve
overpressure safety of the hydraulic system
4. roll-off safety at the runways
safety device of the vehicle against falling down
5. foot protection
safety device against squeeze

3.3 Datasheet

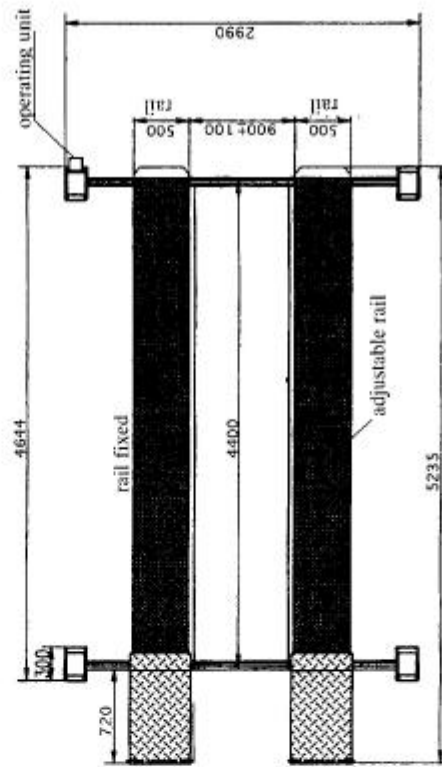
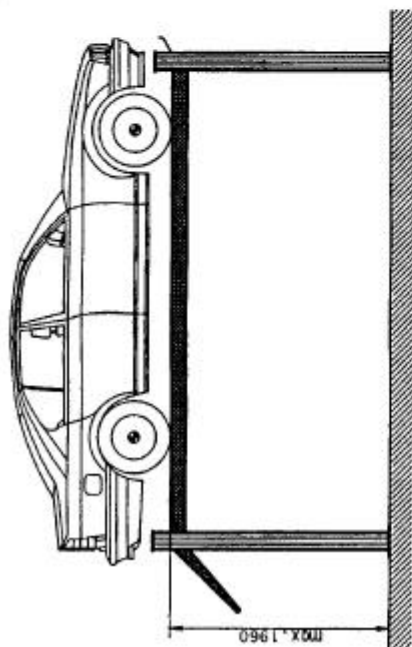
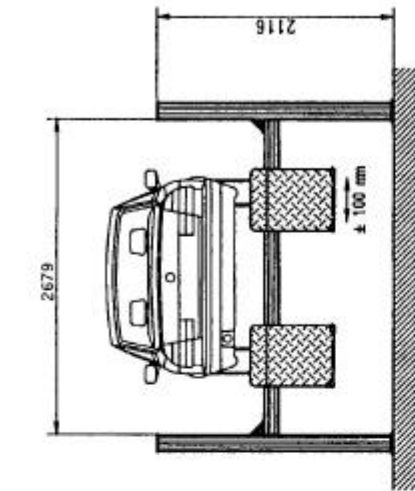

the rail is max. 100mm adjustable
to the right or the left side

- capacity: 3200kg
- length of the rail : 4400 mm
- lifting height: max. 1960 mm
- Lifting time: app. 30sec.
- lifting height: app. 1960 mm;
- motor: 3kw



Data sheet 4.32 H
Masstab 1:40

subject alteration

3.4 Foundation plan

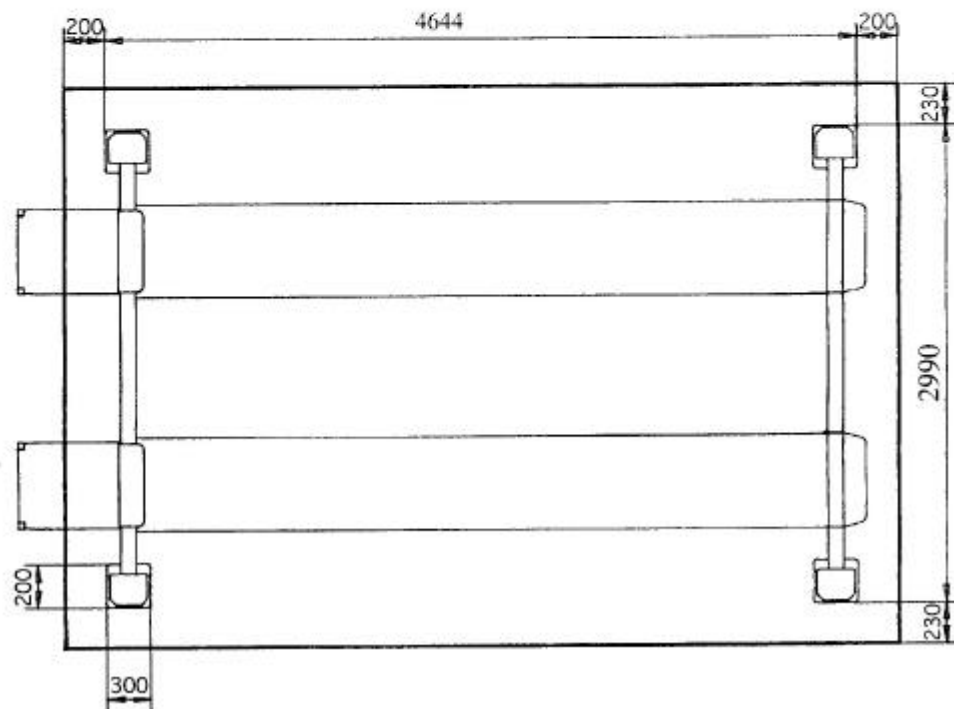
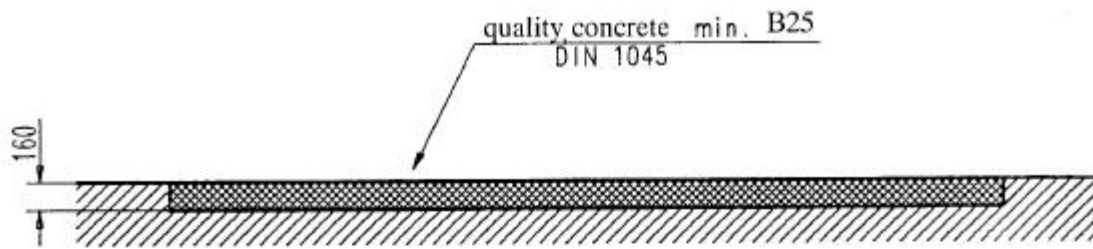

Foundation plan: quality of the concrete minimum. B25
thickness minimum 160 mm

If the concrete is available the quality B25 and the thickness minimum 160 mm must be guaranteed.

3.5 Electrical-diagram drawing

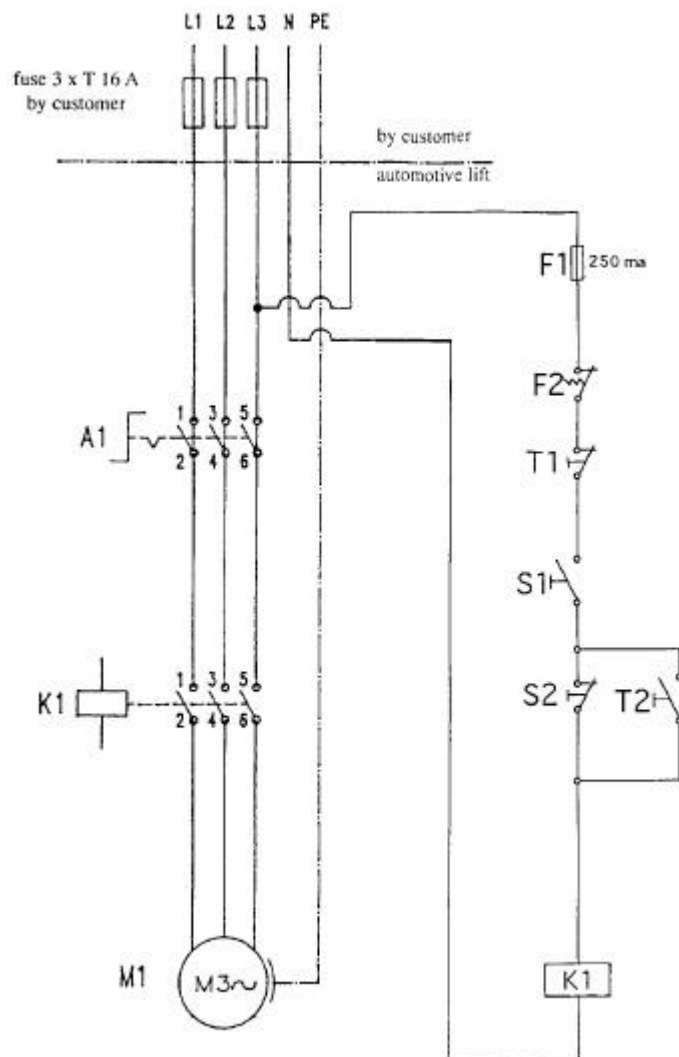

Electrical part list

- A1: main switch
- F1: control fuse 250 mA
- F2: thermo fuse in the motor
- T1: Button "lowering in the ratchet"
- S1: switch "motor for lifting or lowering"
- S2: rope slack switch
- T2: override switch "torn slack"

3.5 Hydraulic diagram

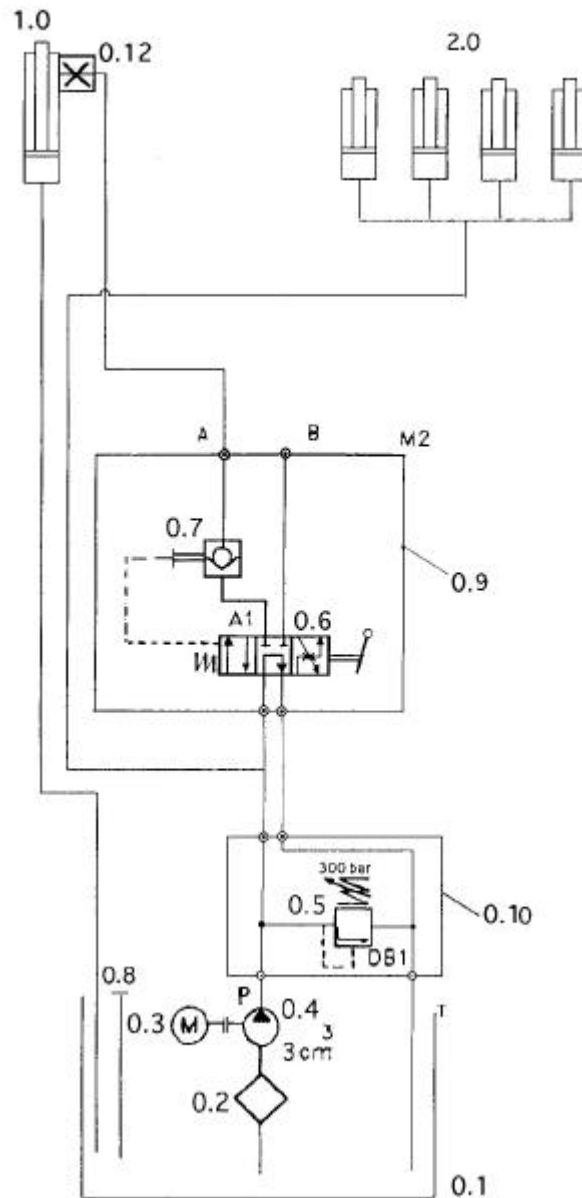

Hydraulic parts list

- 0.1 oil tank
- 0.2 filter
- 0.3 motor
- 0.4 gear pump
- 0.5 pressure control valve
- 0.6 4/3 way valve
- 0.7 holding valve
- 0.8 oil level gauge
- 0.9 hydraulic block
- 0.10 hydraulic block complete
- 0.12 screen
- 1.0 hydraulic cylinder
- 2.0 hydraulic cylinder

4. Safety regulations

Using automotive lifts for working the Regulations of Accident Prevention (VBG1: General Regulations, VBG14: Automotive lifts) must be observed.

Especially the following regulations are very important:

- During working with the lift the operating instructions must be followed.
- The laden weight of the lifted vehicle mustn't be more than 3200 kg for automotive lift
The maximum load sharing is 2:1 in drive in direction or against drive in direction.
- Only trained personnel over the age of 18 years old are to operate this lift.
- During lifting or lowering the vehicle it must be observed from the operator.
- It's not allowed to stay under the lifted or lowered vehicle (except for the operator).
- It's not allowed to transport passengers on the lift or in the vehicle.
- It's not allowed to climb onto the lift or onto a lifted vehicle.
- The automotive lift must be checked from an expert after changes in construction or after repairing.
- It's not allowed to start with operations at the lift before the main switch is switched off.
- It's not allowed to install the standard-automotive lift in hazardous location.

5. Operating instructions



The Safety Regulations must be observed during working with the automotive lift. Read the safety regulations in chapter 4 carefully before working with the lift!

The operating element are shown in picture 1.

5.1 Lifting the vehicle with automotive lift

- Drive the vehicle on the lift, longitudinal direction and transverse direction in centre.



Each wheel must stand completely on the rail, otherwise the vehicle might fall down.

- Safe the vehicle against rolling away, switch into gear.
- Check the dangerous places of the lift and be sure that there are no objects or people in the immediate area of the lift or on the lift.
- Switch on the main switch on position "1".
- Put the lever on the rail on position "lifting" (see pic.1) observe the position of the lever.
- Lift the vehicle to the working height. Observe the complete process.

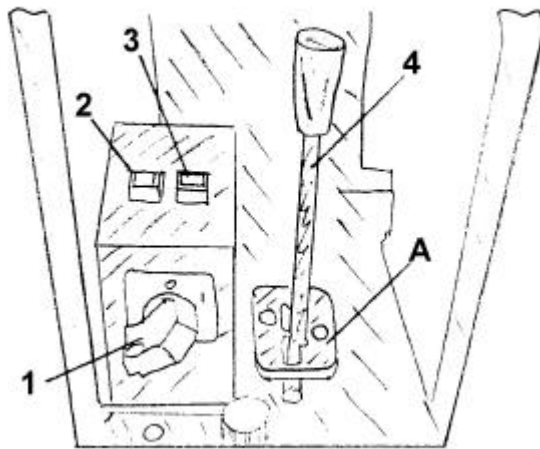

pic. 1 operating unit
1 main switch
2 override switch
3 button (lowering in the ratchet)
4 the lever
A position of the lever

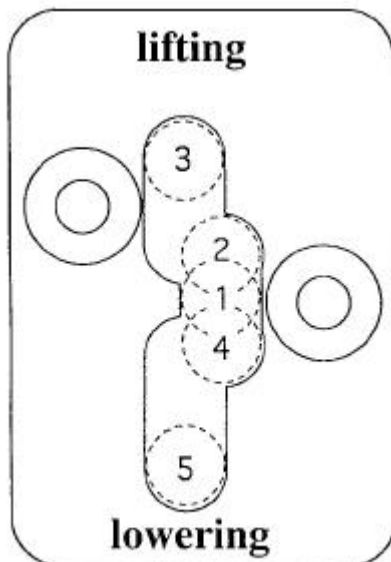

pic 2: the position of the lever
1 neutral position
2 unlocking of the ratchet
3 the lift is raising – the ratchets are must be free
4 unlocking of the ratchet
5 the lift is lowering – the ratchets are must be free

5.2 Lowering the vehicle with the automotive lift

- Check the dangerous places of the lift and be sure that there are no objects or people in the immediate area of the lift or on the lift.
- Push the lever slowly on position “lowering” (see. Pic.2; pos. 5) until the ratchets are free. Then push the lever on position (5). The lift starts to lower.
- If the lift is in the ratchet; first: push the lever on position (2); second: on position (3) until the ratchets are free and then lower the lift how described in the manual.
- Lower the lift on the lift working height or the lowest position. Observe the complete process.
- If the lift is in the lowest position drive the vehicle from the lift.

5.3 Lowering the automotive lift in the ratchet strip

- Check the dangerous places of the lift and be sure that there are no objects or people in the immediate area of the lift or on the lift.
- Press the button “lowering in the ratchet” (see pic.1, pos. 3 on the operating unit) and hold it. Then push the lever slowly on position (5) (see pic. 2)
- Press the button so long until all four ratchets are locked. The lift is lowering in the next possible ratchet.

5.4 Raise the automotive lift out of the ratchet strip

- Check the dangerous places of the lift and be sure that there are no objects or people in the immediate area of the lift or on the lift.
- The lift switched off , if the lift is in the ratchets and the ropes are slack. Check the ropes whether the ropes are flabby or torn. (visual inspection and touch inspection).
If the ropes are flabby, press the override switch (see pic.1) and the lever on position “lifting”
- If the ropes are not torn, all four sides of the lift will raising. The lift has the normal function. Push the lever on position (3) until the ratchets are free. Then lower the lift, push the lever slowly on position (4) and then on position (5). The lift starts the lowering. If necessary press the override button.



Press only the override switch, if the ropes are flabby. Do not press the override switch if the ropes are torn! Otherwise it exist the danger for the health and the life, for damage the automotive lift and the vehicle.

- If one rope is torn, only three sides of the lift will raising! Switch off the lift and lock the main switch. Call the technical service.

5.5 Driving on a obstacle

If the lift is running onto an obstacle during the lowering, it stops automatically (flabby switch). In this case push the lever “lifting” until the obstacle can be removed.

6. Troubleshooting

If the lift does not work properly, the reason for this might be quite simple. Please check the lift for the potential reasons mentioned on the following pages. If the cause of trouble cannot be found, please call the technical service.



Repairs at the lifts security devices, repairs and examinations of the electrical fittings may only be performed by specialists.

Problem: Motor does not start!

- Potential causes:
- *Main switch is not engaged.*
 - *The feed line is cut.*
 - *Power failure.*
 - *Thermofuse in the motor is activ (let it cool down approx. 10 min).*
 - *The rope is torn and the limit switch is pressed.*

Problem: Motor starts, lift does not raise!

- Potential causes:
- *The vehicle is too heavy*
 - *Level of the oil is too low.*
 - *The emergency lowering screws are not closed.*
 - *The hydraulic hoses are dirty.*
 - *The level is not in the right position*

Problem: The lift does not lowered!

- Potential causes:
- *The lift is standing on a obstacle.*
 - *The hydraulic valve is defective.*
 - *The level is not in the right position*
 - *The lift is in the ratchet.*

6.1 Emergency lowering in case of power failure or defective valve

In this case of power failure , the ratchets can not more open. Therefore the lift can not be lowered. In this case there is possible to lower the lift by opening the hydraulic valve manually, so the vehicle can be driven off.



The emergency lowering can only be performed by persons instructed to use the lift. Please refer to the regulation „Lowering the vehicle“.



Every kind of external leakage must be removed. This is necessary particularly before emergency lowering. The emergency lowering must be carried out in this order. Otherwise a malfunction can lead to damage or lead to danger for body and lives.



In the case of power failure, the emergency lowering can only be performed when the ratchets are not engaged. (when the ratchets can be pulled back manually)

- Pull back the ratchets manually and lay a suitable support (wood) between the ratchet strip and the ratchet. Or fix the ratchet with the help of a wire. This step should be taken at all four ratchets.
- Control the dangerous places of the lift and be sure that there are no objects or people in the immediate area of the lift or on the lift.
- Push the lever slowly on position “lowering”. Observe the complete process.
- Lower the lift in the lowest position.
- If the lift is in the lowest position, remove the supports at the ratchets



After finishing the emergency lowering, remove the supports at the ratchets. Otherwise a malfunction of the lift can occur.



To guarantee the safe running of the lift, the supports must be removed.

- Do not work with the lift until the faulty parts are exchanged. Call the service-partner.



Switch off the main switch and lock it. Do not work with the lift until the faulty parts are exchanged.

7. Maintenance

A regular service has to be performed every three months by the lift operator according to the following schedule. If the lift is in continuous operation or in a dirty environment, the maintenance rate has to be increased.

During daily operation the lift has to be watched carefully for its correct function. In case of any malfunction the technical service of the retailer has to be informed.

7.1 Inspection and Maintenance of Nussbaum lifts

Nussbaum lifts have been designed and manufactured for longevity and safe operation. Proper installation and operation, regular inspections and ensuing preventative maintenance by authorized personnel and product care, are the key to operators safety, product reliability, low overall repair costs, qualified warranty claims and finally, longevity of the lift. Our lifts are German TÜV and European CE certified and meet or surpass the safety standards of the countries in which we sell. European regulations for instance, oblige inspection by qualified personnel, every 12 months during the life span of the lift.

Whatever the regulations are in a given country, the following are the minimum, requirements regarding the maintenance of Nussbaum lifts.

1. Product care. On an daily/weekly basis by lift operator

Always contact qualified service personnel whenever there is a safety issue. Check for anomalies at all times in particular after electrical power failure or flooding of the shop floor (check sealing of the canister of in-ground TOP lifts). Execute equalization procedure of lifts with master/slave system (JUMBO- and UNI Lifts). Check for leaky and kinked pipes and hoses. Clean the lift and the floor with a non-aggressive detergent. Prevent corrosion by oiling metallic parts or paint retouch. Check filters, grease/lubrication needs and air pressure. Check condition of lifting pads/polymer supports.

2. Inspection. At least once a year by qualified technician

Safety related:

- Check the proper functioning of all mechanical, electrical, hydraulic and pneumatic safety locking functions
- Check for proper anchoring of the lift to the floor and floor cracks
- Check for potential structural failures, in particular of welded parts
- Check for bending or distortion of mechanical parts

Maintenance related:

- Check for hydraulic/air leaks and condition of pipes/hoses
- Check electrical connections, switches and fuses
- Check for wear of all bearings, hinge points and shafts
- Check condition of lifting pads
- Check for leakage to the in-ground lift canister
- Check for corrosion building

3. Preventative maintenance by qualified technician

- Replace **hydraulic oil** once every year. 14 litre , 32 cst.
- Replace **hydraulic hoses** at least once every 6 years
- Take proper **product care** as recommended in point 1
- Replace **safety related** parts whenever there is the slightest doubt
- Replace or repair worn or improper functioning **maintenance related** parts, before they break down. This avoids costly repairs at a later date

- Clean the drip pan for waste oil (under the cylinder)
- Check the condition of the ropes. If torn wires can be discovered the complete rope-set must be exchanged.
- Clean the piston rods of the hydraulic cylinder from sand and dirt
- Clean and lubricate the running pieces of the lift (hinge bolts, sliding pieces, sliding surfaces).

Inspection, repair and maintenance may be done by technicians from Nussbaum, Nussbaum's distributor or end-user. This personnel must be trained on the particular models of lift which they service. They must be able to make a judgment as to the repair or maintenance that needs to be done in order to ensure full safety, operational reliability and structural integrity during the life time of the lift. Proper maintenance records should be kept to back up possible warranty claims.

7.2 Cleaning of the automotive lift

A regular and appropriate maintenance served the preservation of the lift.

It can be a prerequisite for claims at possible corrosion.

The best protection for the lift is the regular cleaning of dirt of all manner.

- Including this:

- de-icing salt
- sand, pebble stone, naturail soil
- industrial dust of all manner
- water ; also in connection with other environmental influences
- aggressive deposit of all manner
- constant humidity by insufficient ventilation

How often must the lift be cleaned ?

This is dependent on the use, of the working with the lift, of the cleanness of the workshop and location of the lift. The degree of the dirt is dependent on the season, of the weather conditions and the ventilation of the workshop.

Under bad circumstances it is necessary to clean the lift every week, but a cleaning every month can suffice.

Clean the lift and the floor with a non-aggressive and non-abrasive detergent. Use gentle detergent to clean the parts. Use an standard washing-up liquid and lukewarm water.

- Do not use for cleaning a steam jet cleaning.
- Remove all dirt careful with a sponge if necessary with a brush.
- Pay attention that are no remains of the washing-up liquids on the lift after cleaning.

- Do not use aggressive means for cleaning the workshop floor and the automotive lift.
- A permanent contact with every kind of liquid is forbidden. Do not use any high pressure device for cleaning the lift.

8. Security check

The security check is necessary to guarantee the safety of the lifting during use. It has to be performed in the following cases:

1. Before the initial operation, after the first installation
Use the form “First security check before initiation”
2. In regular intervals after the initial operation, at least annually.
Use the form “Regular security check at least annually”
3. Every time the construction of that particular lift has been changed.
Use the form “Extraordinary security check”



The first and the regular security check must be performed by a competent person. It is recommended to service the lift at this occasion.



After the construction of the lift has been changed (changing the lifting height or capacity for example) and after serious maintenance works (welding on carrying parts) an extraordinary security check must be performed by an expert.

This manual contains form with a schedule for the security checks. Please use the adequate form for the security checks. The form should remain in this manual after they have been filled out. In the following there is a short description about special safety devices.

9. Installation and Initiation

9.1 Regulations for the installation

- The installation of the lift is performed by trained technicians of the manufacturer or its distribution partner. If the operator can provide trained mechanics, he can install the lift by himself. The installation has to be done according to this regulation.
- The standard lift must not be installed in hazardous locations or washing areas.
- Before installation a sufficient foundation must be proved or constructed.
- An even installation place has to be provided. The foundations must be based in a frost resistance depth, both outside and indoors, where you must reckon with frost.
- An electrical supply 3~/N+PE, 400 V, 50 Hz has to be provided (standard version). The supply line must be protected with T16A (VDE0100 German regulation). The minimum diameter amounts to 2,5 mm².
- All cable ducts have to be equipped with protective coverings to prevent accidents.

9.2 Erection and doweling of the lift

It is necessary to dowel the columns at 4 points and to safe the lift against slipping. Normally for this a concrete floor without reinforcement, thickness of 160 mm and quality B 25 is needed. The reinforcement must be checked and calculate by an engineer engaged in statical calculations. In case of doubt a test drill is necessary and a dowel is to put in. Afterwards the dowel is to fasten with a specified torque (example: Liebig 50 Nm). If the necessary torque is too low or if there are cracks in the concrete floor, a foundation in accordance with the sheet "foundation plan" is to erected. As well it must be paid attention that the installation place is even to guarantee a horizontal erection of the lift.

- Put runways on two erection trestles at installation place, pay attention of exactly difference between the runways (refer to data sheet).
- Position the crossbeams on the face of the runways, and connect the hydraulic tubes (see pic. 6.)
- Mount ropes (see pic. 3)

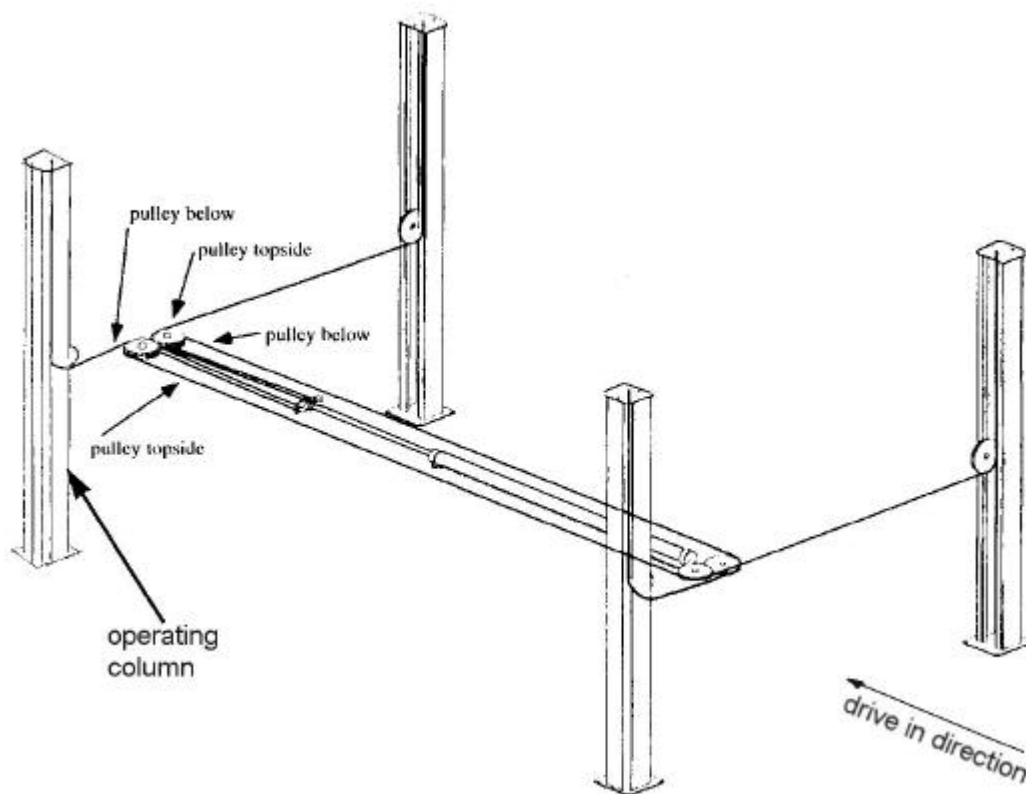

- Position the columns at the ends of the crossbeams.
- Line up operating column (with bubble level) and drill holes for dowel-fixing through four bore-holes of base plates. Clean bore-holes with pressure air. Put in the safety dowels with washers in bore hole.
- Mount the operating unit on the column and connect the hydraulic tubes (see pic 6/7)
- Take carrying ropes through columns to upper side and fix them in the head plate.
- Check the position of the lift and the position of the operating columns again.

- Bore holes to fix the dowels through the borings of the base plates. Clean holes with pressure air. Put in safety dowels with washers in borings.

The manufacturer demands LIEBIG safety dowels type B 15 (german dowel manufacturer) or equal dowels of another manufacturer (with allowance) but observe their regulations! Before doweling check concrete floor with quality B 25 if the concrete floor goes to the top edge of the floor. In this case the dowels have to be chosen according to **picture 8**. If the ground is covered with floor tiles, the dowels have to be chosen according to **picture 9**.

- Tighten the dowels a little.
- Connect power supply:
- Tighten the screws at the crossbeam.
- Fill in the hydraulic-oil, approx. 14 litre.
- Raise the lift a little with the lever (push the lever on position “lifting”)
- Remove the erection trestles.
- Mount the safety ratchets in the column - if necessary lower the lift.

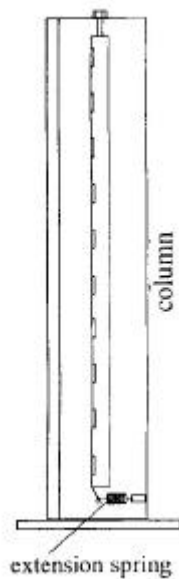

- Lower the lift in the ratchet (read chapter “lowering in the ratchet”)
- Line up the columns with a help of a bubble level again.
- Tighten the dowels with the dynamometric key (example Liebig-dowels $M = 50Nm$)



Each dowel must be tightened with the demanded torque. Otherwise the normal function of the lift can not guaranteed.

- Mount the ramps, the foot protections and the loading ramps.
- Adjust the sliding guidance at the crossbeam (approx. 4-5 mm movement between the sliding guidance and the column).

- Adjust regular height of the rails at all of the four columns by moving the nuts, which fix the carrying ropes in the head plate. For demanded measuring accuracy of all important vehicle manufacturer it is necessary to install the lift very exactly and to line it up. For this to the following points should be paid attention.
- Lift the automotive lift to eye level and lower it down in the ratchet (refer to operating instructions).
- Position each of the measuring scales on the traverse and check niveau of the two rails (if they have got the same level) with land leveler.
- Adjust the rails with the screws of the ratchet-rod (on the "head-plate" at the top of the column).
- Raise and lower the lift several times with load. Check the torque of the dowels and check the hydraulic parts for tightness.
- Mount the covers.

9.3 Adjusting the rail

The standard measure between the rails is 950 mm. It is possible to adjust the rails +/-100 mm (see the datasheet). Lower the lift in the ratchets until there is no tractive power on the ropes .

- Lower the lift in the ratchet.
- Remove the ramp and the roll-off of the rail (only the adjustable rail)
- Remove both cover of the crossbeam.
- Remove the screws and if necessary position supports under the rail.
- Adjust the rail.
- Tighten the screw.
- Mount the cover.
- Mount the ramp and the roll-off safety
- Raise the lift out of the ratchets.

9.4 Initiation



Before the initiation a security check must be performed. therefore use form: First security check.

If the lift is installed by a competent person, he will perform this security check. If the operator installs the lift by himself, he has to instruct a competent person to perform the security check.

The competent confirms the faultless function of the lift in the installation record and form for the security check and allows the lift to be used.



Please send the filled installation record to the manufacturer after installation.

9.5 Changing the installation place

If the place of installation shall be changed, the new place has to be prepared in according to the regulations of the first installation. The changing should be performed in accordance with the following points:

- Position erection trestles under the rails.
- Lower the lift until the rails are lay on the erection trestles.
- Disconnect the hydraulic lines.
- Disconnect electrical current supply from the lift.
- Loose the fixing nuts of the carrying ropes on the head plate and remove them.
- Remove the columns.
- Loose the crossbeams from the rails and pull carrying ropes out of the crossbeams.
- Transport the lift to the new installation place.
- Install lift in accordance with chapter "Installation and Initiation" of the lift.



Use new dowels, the used dowels can not be used anymore.



A security check must be performed before reinitiation by a competent person. Use form "Regular security check".

pic. 5 Position of the columns

it is also possible
to install the operating
unit at this side
of the column

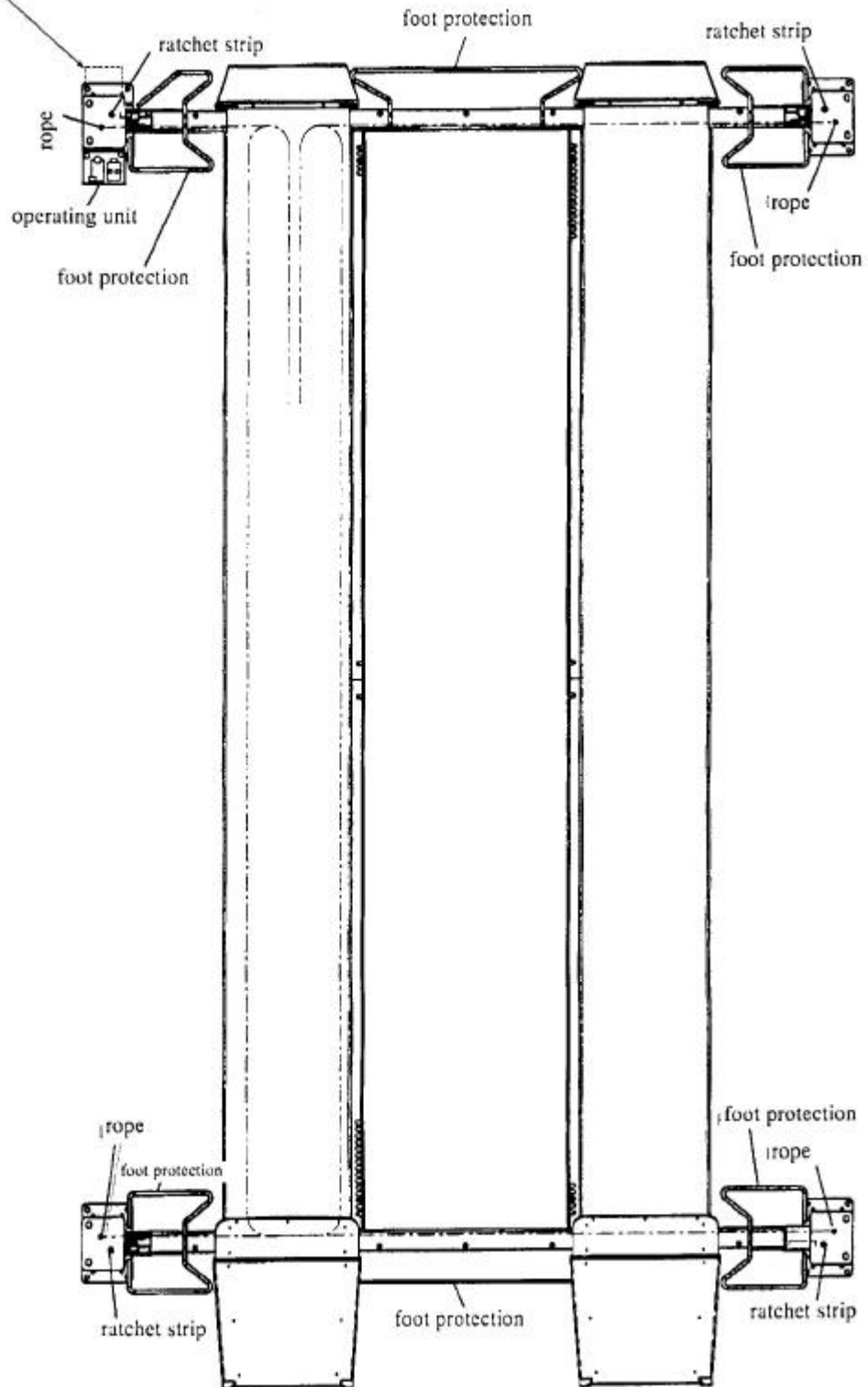

Connections of the hydraulic tubes

pic: 6

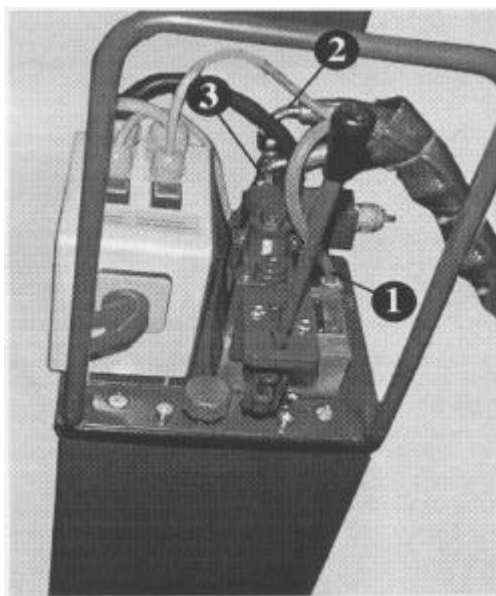
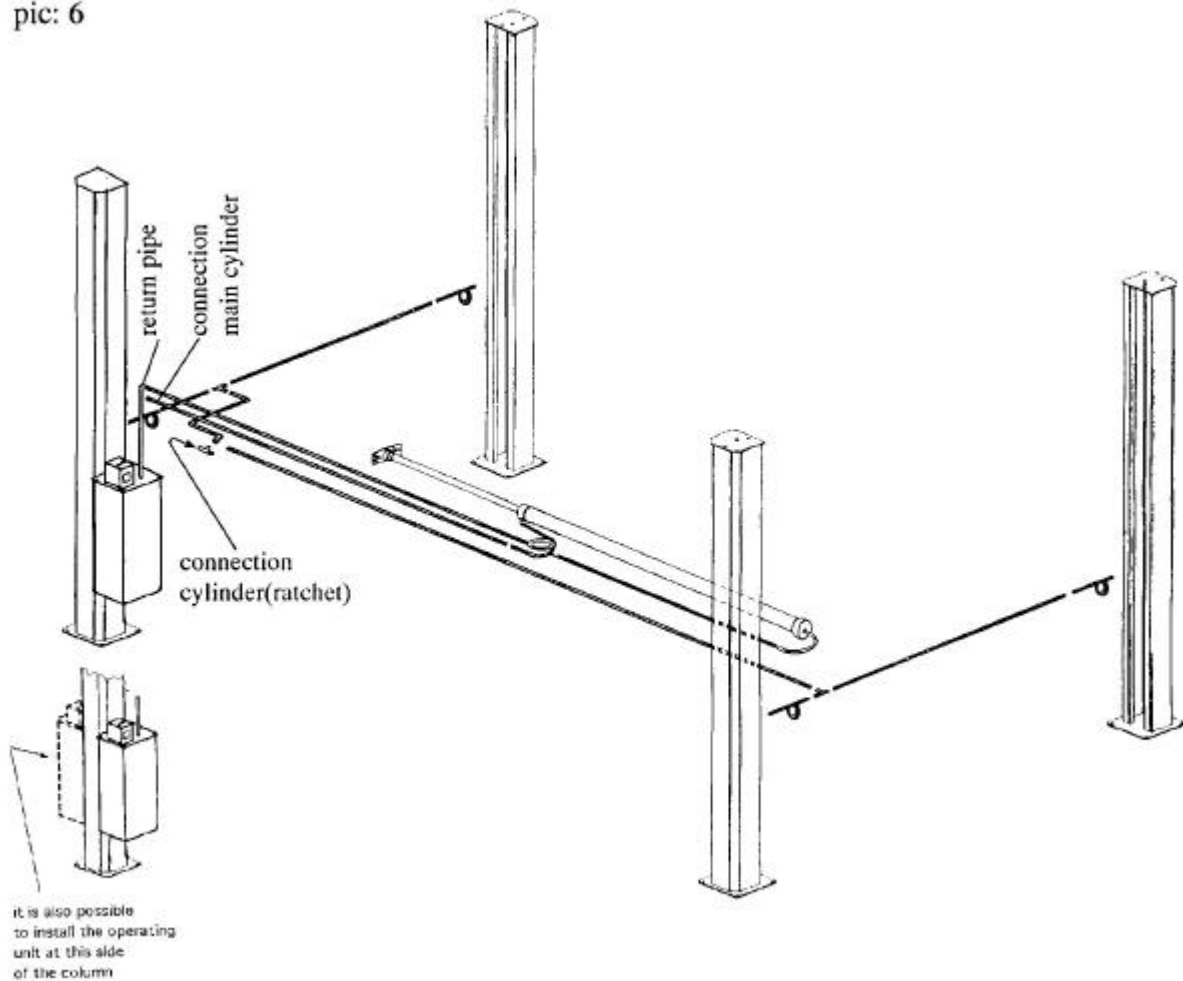

Pic.7

Connection at the operating unit

- 1 return pipe – back from the cylinder in the tank
- 2 hydraulic tube for the cylinder (ratchets)
connect it at the aluminium block.
- 3 hydraulic tube for the main cylinder connect it
at the hand valve (lever).

Pic. 10: choice of the dowel length without floor pavement or tile surface

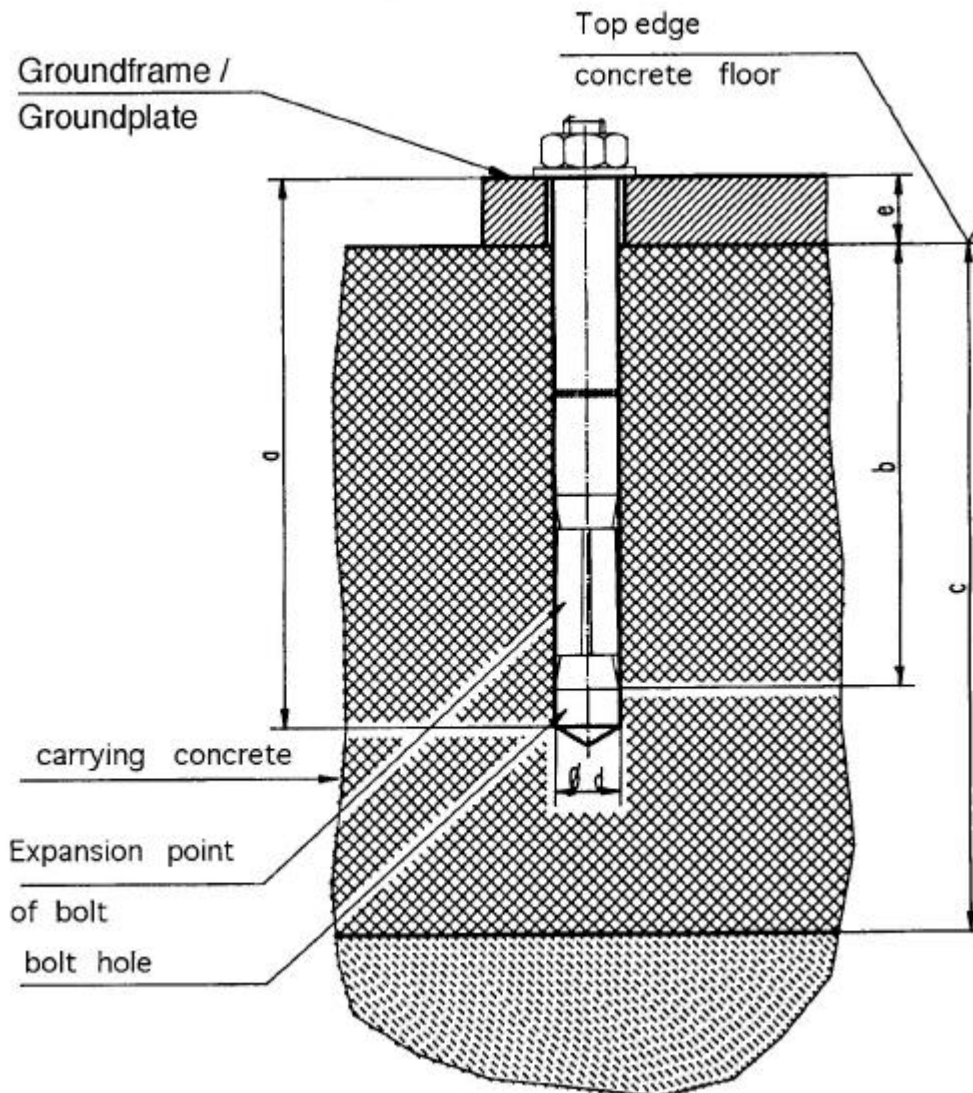

Table to pic. 17

Liebig-dowels

Dowel type		B15/75	B15/95
Drilling depth	a	112	112
Min. anchorage depth	b	72	72
Thickness of concrete	c	160	160
Diameter of bore	d	15	15
Thickness of the lift-pieces	e	0-40	40-65
Number of dowels		16	16
Starting torque		according to dowel manufacturer	



You can use equivalent dowels from another dowel manufacturer (with license) but observe their.

Pic. 11: choice of the dowel length with floor pavement or tile surface

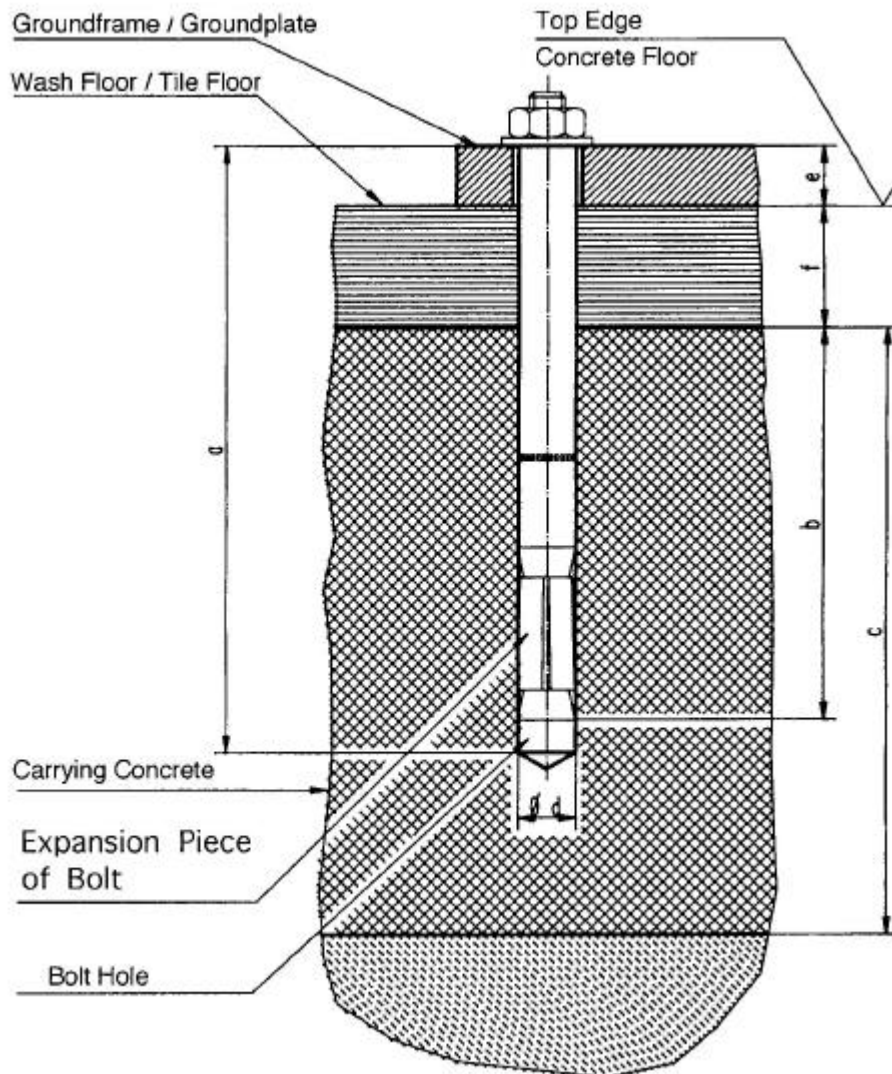

Table to pic. 18

Liebig-dowels

Doweltyp		B15/70	B15/95	B15/120	B15/145
Drilling depth	a	112	137	162	187
Min. anchorage depth	b	72	72	72	72
Thickness of concrete	c	160	160	160	160
Diameter of bore	d	15	15	15	15
Thickness of the lift-pieces	e	0-40	40-65	65-90	90-115
Number of dowels		16	16	16	16
Starting torque		according to dowel manufacturer			



You can use equivalent dowels from another dowel manufacturer (with license) but observe their.

First security check before installation

 Filling out and leave in this manual

kind of check	all right	defect missing	verification	remark
Type plate.....	<input type="checkbox"/>	<input type="checkbox"/>	<input type="checkbox"/>
Short operating instruction.....	<input type="checkbox"/>	<input type="checkbox"/>	<input type="checkbox"/>
Warning designation.....	<input type="checkbox"/>	<input type="checkbox"/>	<input type="checkbox"/>
Designation lifting/lowering.....	<input type="checkbox"/>	<input type="checkbox"/>	<input type="checkbox"/>
Detailed operating instruction.....	<input type="checkbox"/>	<input type="checkbox"/>	<input type="checkbox"/>
Function operating lever.....	<input type="checkbox"/>	<input type="checkbox"/>	<input type="checkbox"/>
Safety device of hinge bolt.....	<input type="checkbox"/>	<input type="checkbox"/>	<input type="checkbox"/>
Condition/Function Ramps.....	<input type="checkbox"/>	<input type="checkbox"/>	<input type="checkbox"/>
Condition automotive lift.....	<input type="checkbox"/>	<input type="checkbox"/>	<input type="checkbox"/>
Securing of bolts.....	<input type="checkbox"/>	<input type="checkbox"/>	<input type="checkbox"/>
Construction (deformation, cracking)	<input type="checkbox"/>	<input type="checkbox"/>	<input type="checkbox"/>
Torque of the dowels	<input type="checkbox"/>	<input type="checkbox"/>	<input type="checkbox"/>
Fixed seat of the screws.....	<input type="checkbox"/>	<input type="checkbox"/>	<input type="checkbox"/>
Condition operating unit.....	<input type="checkbox"/>	<input type="checkbox"/>	<input type="checkbox"/>
Condition surface piston rod	<input type="checkbox"/>	<input type="checkbox"/>	<input type="checkbox"/>
Condition coverings.....	<input type="checkbox"/>	<input type="checkbox"/>	<input type="checkbox"/>
Condition electrical wires	<input type="checkbox"/>	<input type="checkbox"/>	<input type="checkbox"/>
Level of hydraulic oil	<input type="checkbox"/>	<input type="checkbox"/>	<input type="checkbox"/>
Closeness of the hydraulic system.....	<input type="checkbox"/>	<input type="checkbox"/>	<input type="checkbox"/>
Condition hydraulic hoses.....	<input type="checkbox"/>	<input type="checkbox"/>	<input type="checkbox"/>
Function test with vehicle.....	<input type="checkbox"/>	<input type="checkbox"/>	<input type="checkbox"/>
Function torn rope switch.....	<input type="checkbox"/>	<input type="checkbox"/>	<input type="checkbox"/>
Function/condition ratchets.....	<input type="checkbox"/>	<input type="checkbox"/>	<input type="checkbox"/>
Function/condition pulleys.....	<input type="checkbox"/>	<input type="checkbox"/>	<input type="checkbox"/>
Function/condition slide-guidance.....	<input type="checkbox"/>	<input type="checkbox"/>	<input type="checkbox"/>
Condition runways.....	<input type="checkbox"/>	<input type="checkbox"/>	<input type="checkbox"/>
Condition columns.....	<input type="checkbox"/>	<input type="checkbox"/>	<input type="checkbox"/>

(mark here applicable, in case of verification mark in addition to the first mark!)

Security check carried out:.....

Carried out the company:.....

Name, address of the competent:.....

Result of the Check:

- Initiation not permitted, verification necessary
- Initiation possible, repair failures until.....
- No failings, Initiation possible

.....
signature of the expert

.....
signature of the operator

If failures must be repaired:

Failures repaired at:signature of the operator
(Use another form for verification!)

Regular security check

 Filling out and leave in this manual

kind of check	all right	defect missing	ver-ification	remark
Type plate.....	<input type="checkbox"/>	<input type="checkbox"/>	<input type="checkbox"/>
Short operating instruction.....	<input type="checkbox"/>	<input type="checkbox"/>	<input type="checkbox"/>
Warning designation.....	<input type="checkbox"/>	<input type="checkbox"/>	<input type="checkbox"/>
Designation lifting/lowering.....	<input type="checkbox"/>	<input type="checkbox"/>	<input type="checkbox"/>
Detailed operating instruction.....	<input type="checkbox"/>	<input type="checkbox"/>	<input type="checkbox"/>
Function operating lever.....	<input type="checkbox"/>	<input type="checkbox"/>	<input type="checkbox"/>
Safety device of hinge bolt.....	<input type="checkbox"/>	<input type="checkbox"/>	<input type="checkbox"/>
Condition/Function Ramps.....	<input type="checkbox"/>	<input type="checkbox"/>	<input type="checkbox"/>
Condition automotive lift.....	<input type="checkbox"/>	<input type="checkbox"/>	<input type="checkbox"/>
Securing of bolts.....	<input type="checkbox"/>	<input type="checkbox"/>	<input type="checkbox"/>
Construction (deformation, cracking)	<input type="checkbox"/>	<input type="checkbox"/>	<input type="checkbox"/>
Torque of the dowels	<input type="checkbox"/>	<input type="checkbox"/>	<input type="checkbox"/>
Fixed seat of the screws.....	<input type="checkbox"/>	<input type="checkbox"/>	<input type="checkbox"/>
Condition operating unit.....	<input type="checkbox"/>	<input type="checkbox"/>	<input type="checkbox"/>
Condition surface piston rod	<input type="checkbox"/>	<input type="checkbox"/>	<input type="checkbox"/>
Condition coverings.....	<input type="checkbox"/>	<input type="checkbox"/>	<input type="checkbox"/>
Condition electrical wires	<input type="checkbox"/>	<input type="checkbox"/>	<input type="checkbox"/>
Level of hydraulic oil	<input type="checkbox"/>	<input type="checkbox"/>	<input type="checkbox"/>
Closeness of the hydraulic system.....	<input type="checkbox"/>	<input type="checkbox"/>	<input type="checkbox"/>
Condition hydraulic hoses.....	<input type="checkbox"/>	<input type="checkbox"/>	<input type="checkbox"/>
Function test with vehicle.....	<input type="checkbox"/>	<input type="checkbox"/>	<input type="checkbox"/>
Function torn rope switch.....	<input type="checkbox"/>	<input type="checkbox"/>	<input type="checkbox"/>
Function/condition ratchets.....	<input type="checkbox"/>	<input type="checkbox"/>	<input type="checkbox"/>
Function/condition pulleys.....	<input type="checkbox"/>	<input type="checkbox"/>	<input type="checkbox"/>
Function/condition slide-guidance.....	<input type="checkbox"/>	<input type="checkbox"/>	<input type="checkbox"/>
Condition runways.....	<input type="checkbox"/>	<input type="checkbox"/>	<input type="checkbox"/>
Condition columns.....	<input type="checkbox"/>	<input type="checkbox"/>	<input type="checkbox"/>

(mark here applicable, in case of verification mark in addition to the first mark!)

Security check carried out:.....

Carried out the company:.....

Name, address of the competent:.....

Result of the Check:

- Initiation not permitted, verification necessary
- Initiation possible, repair failures until.....
- No failings, Initiation possible

.....
signature of the expert

.....
signature of the operator

If failures must be repaired:

Failures repaired at:signature of the operator
(Use another form for verification!)

Regular security check

 Filling out and leave in this manual

kind of check	all right	defect missing	verification	remark
Type plate.....	<input type="checkbox"/>	<input type="checkbox"/>	<input type="checkbox"/>
Short operating instruction.....	<input type="checkbox"/>	<input type="checkbox"/>	<input type="checkbox"/>
Warning designation.....	<input type="checkbox"/>	<input type="checkbox"/>	<input type="checkbox"/>
Designation lifting/lowering.....	<input type="checkbox"/>	<input type="checkbox"/>	<input type="checkbox"/>
Detailed operating instruction.....	<input type="checkbox"/>	<input type="checkbox"/>	<input type="checkbox"/>
Function operating lever.....	<input type="checkbox"/>	<input type="checkbox"/>	<input type="checkbox"/>
Safety device of hinge bolt.....	<input type="checkbox"/>	<input type="checkbox"/>	<input type="checkbox"/>
Condition/Function Ramps.....	<input type="checkbox"/>	<input type="checkbox"/>	<input type="checkbox"/>
Condition automotive lift.....	<input type="checkbox"/>	<input type="checkbox"/>	<input type="checkbox"/>
Securing of bolts.....	<input type="checkbox"/>	<input type="checkbox"/>	<input type="checkbox"/>
Construction (deformation, cracking)	<input type="checkbox"/>	<input type="checkbox"/>	<input type="checkbox"/>
Torque of the dowels	<input type="checkbox"/>	<input type="checkbox"/>	<input type="checkbox"/>
Fixed seat of the screws.....	<input type="checkbox"/>	<input type="checkbox"/>	<input type="checkbox"/>
Condition operating unit.....	<input type="checkbox"/>	<input type="checkbox"/>	<input type="checkbox"/>
Condition surface piston rod	<input type="checkbox"/>	<input type="checkbox"/>	<input type="checkbox"/>
Condition coverings.....	<input type="checkbox"/>	<input type="checkbox"/>	<input type="checkbox"/>
Condition electrical wires	<input type="checkbox"/>	<input type="checkbox"/>	<input type="checkbox"/>
Level of hydraulic oil	<input type="checkbox"/>	<input type="checkbox"/>	<input type="checkbox"/>
Closeness of the hydraulic system.....	<input type="checkbox"/>	<input type="checkbox"/>	<input type="checkbox"/>
Condition hydraulic hoses.....	<input type="checkbox"/>	<input type="checkbox"/>	<input type="checkbox"/>
Function test with vehicle.....	<input type="checkbox"/>	<input type="checkbox"/>	<input type="checkbox"/>
Function torn rope switch.....	<input type="checkbox"/>	<input type="checkbox"/>	<input type="checkbox"/>
Function/condition ratchets.....	<input type="checkbox"/>	<input type="checkbox"/>	<input type="checkbox"/>
Function/condition pulleys.....	<input type="checkbox"/>	<input type="checkbox"/>	<input type="checkbox"/>
Function/condition slide-guidance.....	<input type="checkbox"/>	<input type="checkbox"/>	<input type="checkbox"/>
Condition runways.....	<input type="checkbox"/>	<input type="checkbox"/>	<input type="checkbox"/>
Condition columns.....	<input type="checkbox"/>	<input type="checkbox"/>	<input type="checkbox"/>

(mark here applicable, in case of verification mark in addition to the first mark!)

Security check carried out:.....

Carried out the company:.....

Name, address of the competent:.....

Result of the Check:

- Initiation not permitted, verification necessary
- Initiation possible, repair failures until.....
- No failings, Initiation possible

.....
signature of the expert

.....
signature of the operator

If failures must be repaired:

Failures repaired at:signature of the operator
(Use another form for verification!)

Regular security check

 Filling out and leave in this manual

kind of check	all right	defect missing	ver- ification	remark
Type plate.....	<input type="checkbox"/>	<input type="checkbox"/>	<input type="checkbox"/>
Short operating instruction.....	<input type="checkbox"/>	<input type="checkbox"/>	<input type="checkbox"/>
Warning designation.....	<input type="checkbox"/>	<input type="checkbox"/>	<input type="checkbox"/>
Designation lifting/lowering.....	<input type="checkbox"/>	<input type="checkbox"/>	<input type="checkbox"/>
Detailed operating instruction.....	<input type="checkbox"/>	<input type="checkbox"/>	<input type="checkbox"/>
Function operating lever.....	<input type="checkbox"/>	<input type="checkbox"/>	<input type="checkbox"/>
Safety device of hinge bolt.....	<input type="checkbox"/>	<input type="checkbox"/>	<input type="checkbox"/>
Condition/Function Ramps.....	<input type="checkbox"/>	<input type="checkbox"/>	<input type="checkbox"/>
Condition automotive lift.....	<input type="checkbox"/>	<input type="checkbox"/>	<input type="checkbox"/>
Securing of bolts.....	<input type="checkbox"/>	<input type="checkbox"/>	<input type="checkbox"/>
Construction (deformation, cracking)	<input type="checkbox"/>	<input type="checkbox"/>	<input type="checkbox"/>
Torque of the dowels	<input type="checkbox"/>	<input type="checkbox"/>	<input type="checkbox"/>
Fixed seat of the screws.....	<input type="checkbox"/>	<input type="checkbox"/>	<input type="checkbox"/>
Condition operating unit.....	<input type="checkbox"/>	<input type="checkbox"/>	<input type="checkbox"/>
Condition surface piston rod	<input type="checkbox"/>	<input type="checkbox"/>	<input type="checkbox"/>
Condition coverings.....	<input type="checkbox"/>	<input type="checkbox"/>	<input type="checkbox"/>
Condition electrical wires	<input type="checkbox"/>	<input type="checkbox"/>	<input type="checkbox"/>
Level of hydraulic oil	<input type="checkbox"/>	<input type="checkbox"/>	<input type="checkbox"/>
Closeness of the hydraulic system.....	<input type="checkbox"/>	<input type="checkbox"/>	<input type="checkbox"/>
Condition hydraulic hoses.....	<input type="checkbox"/>	<input type="checkbox"/>	<input type="checkbox"/>
Function test with vehicle.....	<input type="checkbox"/>	<input type="checkbox"/>	<input type="checkbox"/>
Function torn rope switch.....	<input type="checkbox"/>	<input type="checkbox"/>	<input type="checkbox"/>
Function/condition ratchets.....	<input type="checkbox"/>	<input type="checkbox"/>	<input type="checkbox"/>
Function/condition pulleys.....	<input type="checkbox"/>	<input type="checkbox"/>	<input type="checkbox"/>
Function/condition slide-guidance.....	<input type="checkbox"/>	<input type="checkbox"/>	<input type="checkbox"/>
Condition runways.....	<input type="checkbox"/>	<input type="checkbox"/>	<input type="checkbox"/>
Condition columns.....	<input type="checkbox"/>	<input type="checkbox"/>	<input type="checkbox"/>

(mark here applicable, in case of verification mark in addition to the first mark!)

Security check carried out:.....

Carried out the company:.....

Name, address of the competent:.....

Result of the Check:

- Initiation not permitted, verification necessary
- Initiation possible, repair failures until.....
- No failings, Initiation possible

.....
signature of the expert

.....
signature of the operator

If failures must be repaired:

Failures repaired at:
(Use another form for verification!)

.....signature of the operator

Regular security check

 Filling out and leave in this manual

kind of check	all right	defect missing	ver-ification	remark
Type plate.....	<input type="checkbox"/>	<input type="checkbox"/>	<input type="checkbox"/>
Short operating instruction.....	<input type="checkbox"/>	<input type="checkbox"/>	<input type="checkbox"/>
Warning designation.....	<input type="checkbox"/>	<input type="checkbox"/>	<input type="checkbox"/>
Designation lifting/lowering.....	<input type="checkbox"/>	<input type="checkbox"/>	<input type="checkbox"/>
Detailed operating instruction.....	<input type="checkbox"/>	<input type="checkbox"/>	<input type="checkbox"/>
Function operating lever.....	<input type="checkbox"/>	<input type="checkbox"/>	<input type="checkbox"/>
Safety device of hinge bolt.....	<input type="checkbox"/>	<input type="checkbox"/>	<input type="checkbox"/>
Condition/Function Ramps.....	<input type="checkbox"/>	<input type="checkbox"/>	<input type="checkbox"/>
Condition automotive lift.....	<input type="checkbox"/>	<input type="checkbox"/>	<input type="checkbox"/>
Securing of bolts.....	<input type="checkbox"/>	<input type="checkbox"/>	<input type="checkbox"/>
Construction (deformation, cracking)	<input type="checkbox"/>	<input type="checkbox"/>	<input type="checkbox"/>
Torque of the dowels	<input type="checkbox"/>	<input type="checkbox"/>	<input type="checkbox"/>
Fixed seat of the screws.....	<input type="checkbox"/>	<input type="checkbox"/>	<input type="checkbox"/>
Condition operating unit.....	<input type="checkbox"/>	<input type="checkbox"/>	<input type="checkbox"/>
Condition surface piston rod	<input type="checkbox"/>	<input type="checkbox"/>	<input type="checkbox"/>
Condition coverings.....	<input type="checkbox"/>	<input type="checkbox"/>	<input type="checkbox"/>
Condition electrical wires	<input type="checkbox"/>	<input type="checkbox"/>	<input type="checkbox"/>
Level of hydraulic oil	<input type="checkbox"/>	<input type="checkbox"/>	<input type="checkbox"/>
Closeness of the hydraulic system.....	<input type="checkbox"/>	<input type="checkbox"/>	<input type="checkbox"/>
Condition hydraulic hoses.....	<input type="checkbox"/>	<input type="checkbox"/>	<input type="checkbox"/>
Function test with vehicle.....	<input type="checkbox"/>	<input type="checkbox"/>	<input type="checkbox"/>
Function torn rope switch.....	<input type="checkbox"/>	<input type="checkbox"/>	<input type="checkbox"/>
Function/condition ratchets.....	<input type="checkbox"/>	<input type="checkbox"/>	<input type="checkbox"/>
Function/condition pulleys.....	<input type="checkbox"/>	<input type="checkbox"/>	<input type="checkbox"/>
Function/condition slide-guidance.....	<input type="checkbox"/>	<input type="checkbox"/>	<input type="checkbox"/>
Condition runways.....	<input type="checkbox"/>	<input type="checkbox"/>	<input type="checkbox"/>
Condition columns.....	<input type="checkbox"/>	<input type="checkbox"/>	<input type="checkbox"/>

(mark here applicable, in case of verification mark in addition to the first mark!)

Security check carried out:.....

Carried out the company:.....

Name, address of the competent:.....

Result of the Check:

- Initiation not permitted, verification necessary
- Initiation possible, repair failures until.....
- No failings, Initiation possible

.....
signature of the expert

.....
signature of the operator

If failures must be repaired:

Failures repaired at:
(Use another form for verification!)

.....signature of the operator

Regular security check

 Filling out and leave in this manual

kind of check	all right	defect missing	ver-ification	remark
Type plate.....	<input type="checkbox"/>	<input type="checkbox"/>	<input type="checkbox"/>
Short operating instruction.....	<input type="checkbox"/>	<input type="checkbox"/>	<input type="checkbox"/>
Warning designation.....	<input type="checkbox"/>	<input type="checkbox"/>	<input type="checkbox"/>
Designation lifting/lowering.....	<input type="checkbox"/>	<input type="checkbox"/>	<input type="checkbox"/>
Detailed operating instruction.....	<input type="checkbox"/>	<input type="checkbox"/>	<input type="checkbox"/>
Function operating lever.....	<input type="checkbox"/>	<input type="checkbox"/>	<input type="checkbox"/>
Safety device of hinge bolt.....	<input type="checkbox"/>	<input type="checkbox"/>	<input type="checkbox"/>
Condition/Function Ramps.....	<input type="checkbox"/>	<input type="checkbox"/>	<input type="checkbox"/>
Condition automotive lift.....	<input type="checkbox"/>	<input type="checkbox"/>	<input type="checkbox"/>
Securing of bolts.....	<input type="checkbox"/>	<input type="checkbox"/>	<input type="checkbox"/>
Construction (deformation, cracking)	<input type="checkbox"/>	<input type="checkbox"/>	<input type="checkbox"/>
Torque of the dowels	<input type="checkbox"/>	<input type="checkbox"/>	<input type="checkbox"/>
Fixed seat of the screws.....	<input type="checkbox"/>	<input type="checkbox"/>	<input type="checkbox"/>
Condition operating unit.....	<input type="checkbox"/>	<input type="checkbox"/>	<input type="checkbox"/>
Condition surface piston rod	<input type="checkbox"/>	<input type="checkbox"/>	<input type="checkbox"/>
Condition coverings.....	<input type="checkbox"/>	<input type="checkbox"/>	<input type="checkbox"/>
Condition electrical wires	<input type="checkbox"/>	<input type="checkbox"/>	<input type="checkbox"/>
Level of hydraulic oil	<input type="checkbox"/>	<input type="checkbox"/>	<input type="checkbox"/>
Closeness of the hydraulic system.....	<input type="checkbox"/>	<input type="checkbox"/>	<input type="checkbox"/>
Condition hydraulic hoses.....	<input type="checkbox"/>	<input type="checkbox"/>	<input type="checkbox"/>
Function test with vehicle.....	<input type="checkbox"/>	<input type="checkbox"/>	<input type="checkbox"/>
Function torn rope switch.....	<input type="checkbox"/>	<input type="checkbox"/>	<input type="checkbox"/>
Function/condition ratchets.....	<input type="checkbox"/>	<input type="checkbox"/>	<input type="checkbox"/>
Function/condition pulleys.....	<input type="checkbox"/>	<input type="checkbox"/>	<input type="checkbox"/>
Function/condition slide-guidance.....	<input type="checkbox"/>	<input type="checkbox"/>	<input type="checkbox"/>
Condition runways.....	<input type="checkbox"/>	<input type="checkbox"/>	<input type="checkbox"/>
Condition columns.....	<input type="checkbox"/>	<input type="checkbox"/>	<input type="checkbox"/>

(mark here applicable, in case of verification mark in addition to the first mark!)

Security check carried out:.....

Carried out the company:.....

Name, address of the competent:.....

Result of the Check:

- Initiation not permitted, verification necessary
- Initiation possible, repair failures until.....
- No failings, Initiation possible

.....
signature of the expert

.....
signature of the operator

If failures must be repaired:

Failures repaired at:signature of the operator
(Use another form for verification!)

Regular security check

 Filling out and leave in this manual

kind of check	all right	defect missing	verification	remark
Type plate.....	<input type="checkbox"/>	<input type="checkbox"/>	<input type="checkbox"/>
Short operating instruction.....	<input type="checkbox"/>	<input type="checkbox"/>	<input type="checkbox"/>
Warning designation.....	<input type="checkbox"/>	<input type="checkbox"/>	<input type="checkbox"/>
Designation lifting/lowering.....	<input type="checkbox"/>	<input type="checkbox"/>	<input type="checkbox"/>
Detailed operating instruction.....	<input type="checkbox"/>	<input type="checkbox"/>	<input type="checkbox"/>
Function operating lever.....	<input type="checkbox"/>	<input type="checkbox"/>	<input type="checkbox"/>
Safety device of hinge bolt.....	<input type="checkbox"/>	<input type="checkbox"/>	<input type="checkbox"/>
Condition/Function Ramps.....	<input type="checkbox"/>	<input type="checkbox"/>	<input type="checkbox"/>
Condition automotive lift.....	<input type="checkbox"/>	<input type="checkbox"/>	<input type="checkbox"/>
Securing of bolts.....	<input type="checkbox"/>	<input type="checkbox"/>	<input type="checkbox"/>
Construction (deformation, cracking)	<input type="checkbox"/>	<input type="checkbox"/>	<input type="checkbox"/>
Torque of the dowels	<input type="checkbox"/>	<input type="checkbox"/>	<input type="checkbox"/>
Fixed seat of the screws.....	<input type="checkbox"/>	<input type="checkbox"/>	<input type="checkbox"/>
Condition operating unit.....	<input type="checkbox"/>	<input type="checkbox"/>	<input type="checkbox"/>
Condition surface piston rod	<input type="checkbox"/>	<input type="checkbox"/>	<input type="checkbox"/>
Condition coverings.....	<input type="checkbox"/>	<input type="checkbox"/>	<input type="checkbox"/>
Condition electrical wires	<input type="checkbox"/>	<input type="checkbox"/>	<input type="checkbox"/>
Level of hydraulic oil	<input type="checkbox"/>	<input type="checkbox"/>	<input type="checkbox"/>
Closeness of the hydraulic system.....	<input type="checkbox"/>	<input type="checkbox"/>	<input type="checkbox"/>
Condition hydraulic hoses.....	<input type="checkbox"/>	<input type="checkbox"/>	<input type="checkbox"/>
Function test with vehicle.....	<input type="checkbox"/>	<input type="checkbox"/>	<input type="checkbox"/>
Function torn rope switch.....	<input type="checkbox"/>	<input type="checkbox"/>	<input type="checkbox"/>
Function/condition ratchets.....	<input type="checkbox"/>	<input type="checkbox"/>	<input type="checkbox"/>
Function/condition pulleys.....	<input type="checkbox"/>	<input type="checkbox"/>	<input type="checkbox"/>
Function/condition slide-guidance.....	<input type="checkbox"/>	<input type="checkbox"/>	<input type="checkbox"/>
Condition runways.....	<input type="checkbox"/>	<input type="checkbox"/>	<input type="checkbox"/>
Condition columns.....	<input type="checkbox"/>	<input type="checkbox"/>	<input type="checkbox"/>

(mark here applicable, in case of verification mark in addition to the first mark!)

Security check carried out:.....

Carried out the company:.....

Name, address of the competent:.....

Result of the Check:

- Initiation not permitted, verification necessary
- Initiation possible, repair failures until.....
- No failings, Initiation possible

.....
signature of the expert

.....
signature of the operator

If failures must be repaired:

Failures repaired at:
(Use another form for verification!)

.....signature of the operator

Regular security check

 Filling out and leave in this manual

kind of check	all right	defect missing	ver-ification	remark
Type plate.....	<input type="checkbox"/>	<input type="checkbox"/>	<input type="checkbox"/>
Short operating instruction.....	<input type="checkbox"/>	<input type="checkbox"/>	<input type="checkbox"/>
Warning designation.....	<input type="checkbox"/>	<input type="checkbox"/>	<input type="checkbox"/>
Designation lifting/lowering.....	<input type="checkbox"/>	<input type="checkbox"/>	<input type="checkbox"/>
Detailed operating instruction.....	<input type="checkbox"/>	<input type="checkbox"/>	<input type="checkbox"/>
Function operating lever.....	<input type="checkbox"/>	<input type="checkbox"/>	<input type="checkbox"/>
Safety device of hinge bolt.....	<input type="checkbox"/>	<input type="checkbox"/>	<input type="checkbox"/>
Condition/Function Ramps.....	<input type="checkbox"/>	<input type="checkbox"/>	<input type="checkbox"/>
Condition automotive lift.....	<input type="checkbox"/>	<input type="checkbox"/>	<input type="checkbox"/>
Securing of bolts.....	<input type="checkbox"/>	<input type="checkbox"/>	<input type="checkbox"/>
Construction (deformation, cracking)	<input type="checkbox"/>	<input type="checkbox"/>	<input type="checkbox"/>
Torque of the dowels	<input type="checkbox"/>	<input type="checkbox"/>	<input type="checkbox"/>
Fixed seat of the screws.....	<input type="checkbox"/>	<input type="checkbox"/>	<input type="checkbox"/>
Condition operating unit.....	<input type="checkbox"/>	<input type="checkbox"/>	<input type="checkbox"/>
Condition surface piston rod	<input type="checkbox"/>	<input type="checkbox"/>	<input type="checkbox"/>
Condition coverings.....	<input type="checkbox"/>	<input type="checkbox"/>	<input type="checkbox"/>
Condition electrical wires	<input type="checkbox"/>	<input type="checkbox"/>	<input type="checkbox"/>
Level of hydraulic oil	<input type="checkbox"/>	<input type="checkbox"/>	<input type="checkbox"/>
Closeness of the hydraulic system.....	<input type="checkbox"/>	<input type="checkbox"/>	<input type="checkbox"/>
Condition hydraulic hoses.....	<input type="checkbox"/>	<input type="checkbox"/>	<input type="checkbox"/>
Function test with vehicle.....	<input type="checkbox"/>	<input type="checkbox"/>	<input type="checkbox"/>
Function torn rope switch.....	<input type="checkbox"/>	<input type="checkbox"/>	<input type="checkbox"/>
Function/condition ratchets.....	<input type="checkbox"/>	<input type="checkbox"/>	<input type="checkbox"/>
Function/condition pulleys.....	<input type="checkbox"/>	<input type="checkbox"/>	<input type="checkbox"/>
Function/condition slide-guidance.....	<input type="checkbox"/>	<input type="checkbox"/>	<input type="checkbox"/>
Condition runways.....	<input type="checkbox"/>	<input type="checkbox"/>	<input type="checkbox"/>
Condition columns.....	<input type="checkbox"/>	<input type="checkbox"/>	<input type="checkbox"/>

(mark here applicable, in case of verification mark in addition to the first mark!)

Security check carried out:.....

Carried out the company:.....

Name, address of the competent:.....

Result of the Check:

- Initiation not permitted, verification necessary
- Initiation possible, repair failures until.....
- No failings, Initiation possible

.....
signature of the expert

.....
signature of the operator

If failures must be repaired:

Failures repaired at:signature of the operator
(Use another form for verification!)

Regular security check

 Filling out and leave in this manual

kind of check	all right	defect missing	ver-ification	remark
Type plate.....	<input type="checkbox"/>	<input type="checkbox"/>	<input type="checkbox"/>
Short operating instruction.....	<input type="checkbox"/>	<input type="checkbox"/>	<input type="checkbox"/>
Warning designation.....	<input type="checkbox"/>	<input type="checkbox"/>	<input type="checkbox"/>
Designation lifting/lowering.....	<input type="checkbox"/>	<input type="checkbox"/>	<input type="checkbox"/>
Detailed operating instruction.....	<input type="checkbox"/>	<input type="checkbox"/>	<input type="checkbox"/>
Function operating lever.....	<input type="checkbox"/>	<input type="checkbox"/>	<input type="checkbox"/>
Safety device of hinge bolt.....	<input type="checkbox"/>	<input type="checkbox"/>	<input type="checkbox"/>
Condition/Function Ramps.....	<input type="checkbox"/>	<input type="checkbox"/>	<input type="checkbox"/>
Condition automotive lift.....	<input type="checkbox"/>	<input type="checkbox"/>	<input type="checkbox"/>
Securing of bolts.....	<input type="checkbox"/>	<input type="checkbox"/>	<input type="checkbox"/>
Construction (deformation, cracking)	<input type="checkbox"/>	<input type="checkbox"/>	<input type="checkbox"/>
Torque of the dowels	<input type="checkbox"/>	<input type="checkbox"/>	<input type="checkbox"/>
Fixed seat of the screws.....	<input type="checkbox"/>	<input type="checkbox"/>	<input type="checkbox"/>
Condition operating unit.....	<input type="checkbox"/>	<input type="checkbox"/>	<input type="checkbox"/>
Condition surface piston rod	<input type="checkbox"/>	<input type="checkbox"/>	<input type="checkbox"/>
Condition coverings.....	<input type="checkbox"/>	<input type="checkbox"/>	<input type="checkbox"/>
Condition electrical wires	<input type="checkbox"/>	<input type="checkbox"/>	<input type="checkbox"/>
Level of hydraulic oil	<input type="checkbox"/>	<input type="checkbox"/>	<input type="checkbox"/>
Closeness of the hydraulic system.....	<input type="checkbox"/>	<input type="checkbox"/>	<input type="checkbox"/>
Condition hydraulic hoses.....	<input type="checkbox"/>	<input type="checkbox"/>	<input type="checkbox"/>
Function test with vehicle.....	<input type="checkbox"/>	<input type="checkbox"/>	<input type="checkbox"/>
Function torn rope switch.....	<input type="checkbox"/>	<input type="checkbox"/>	<input type="checkbox"/>
Function/condition ratchets.....	<input type="checkbox"/>	<input type="checkbox"/>	<input type="checkbox"/>
Function/condition pulleys.....	<input type="checkbox"/>	<input type="checkbox"/>	<input type="checkbox"/>
Function/condition slide-guidance.....	<input type="checkbox"/>	<input type="checkbox"/>	<input type="checkbox"/>
Condition runways.....	<input type="checkbox"/>	<input type="checkbox"/>	<input type="checkbox"/>
Condition columns.....	<input type="checkbox"/>	<input type="checkbox"/>	<input type="checkbox"/>

(mark here applicable, in case of verification mark in addition to the first mark!)

Security check carried out:.....

Carried out the company:.....

Name, address of the competent:.....

Result of the Check:

- Initiation not permitted, verification necessary
- Initiation possible, repair failures until.....
- No failings, Initiation possible

.....
signature of the expert

.....
signature of the operator

If failures must be repaired:

Failures repaired at:signature of the operator
(Use another form for verification!)

Extraordinary security check

 Filling out and leave in this manual

kind of check	all right	defect missing	verification	remark
Type plate.....	<input type="checkbox"/>	<input type="checkbox"/>	<input type="checkbox"/>
Short operating instruction.....	<input type="checkbox"/>	<input type="checkbox"/>	<input type="checkbox"/>
Warning designation.....	<input type="checkbox"/>	<input type="checkbox"/>	<input type="checkbox"/>
Designation lifting/lowering.....	<input type="checkbox"/>	<input type="checkbox"/>	<input type="checkbox"/>
Detailed operating instruction.....	<input type="checkbox"/>	<input type="checkbox"/>	<input type="checkbox"/>
Function operating lever.....	<input type="checkbox"/>	<input type="checkbox"/>	<input type="checkbox"/>
Safety device of hinge bolt.....	<input type="checkbox"/>	<input type="checkbox"/>	<input type="checkbox"/>
Condition/Function Ramps.....	<input type="checkbox"/>	<input type="checkbox"/>	<input type="checkbox"/>
Condition automotive lift.....	<input type="checkbox"/>	<input type="checkbox"/>	<input type="checkbox"/>
Securing of bolts.....	<input type="checkbox"/>	<input type="checkbox"/>	<input type="checkbox"/>
Construction (deformation, cracking)	<input type="checkbox"/>	<input type="checkbox"/>	<input type="checkbox"/>
Torque of the dowels	<input type="checkbox"/>	<input type="checkbox"/>	<input type="checkbox"/>
Fixed seat of the screws.....	<input type="checkbox"/>	<input type="checkbox"/>	<input type="checkbox"/>
Condition operating unit.....	<input type="checkbox"/>	<input type="checkbox"/>	<input type="checkbox"/>
Condition surface piston rod	<input type="checkbox"/>	<input type="checkbox"/>	<input type="checkbox"/>
Condition coverings.....	<input type="checkbox"/>	<input type="checkbox"/>	<input type="checkbox"/>
Condition electrical wires	<input type="checkbox"/>	<input type="checkbox"/>	<input type="checkbox"/>
Level of hydraulic oil	<input type="checkbox"/>	<input type="checkbox"/>	<input type="checkbox"/>
Closeness of the hydraulic system.....	<input type="checkbox"/>	<input type="checkbox"/>	<input type="checkbox"/>
Condition hydraulic hoses.....	<input type="checkbox"/>	<input type="checkbox"/>	<input type="checkbox"/>
Function test with vehicle.....	<input type="checkbox"/>	<input type="checkbox"/>	<input type="checkbox"/>
Function torn rope switch.....	<input type="checkbox"/>	<input type="checkbox"/>	<input type="checkbox"/>
Function/condition ratchets.....	<input type="checkbox"/>	<input type="checkbox"/>	<input type="checkbox"/>
Function/condition pulleys.....	<input type="checkbox"/>	<input type="checkbox"/>	<input type="checkbox"/>
Function/condition slide-guidance.....	<input type="checkbox"/>	<input type="checkbox"/>	<input type="checkbox"/>
Condition runways.....	<input type="checkbox"/>	<input type="checkbox"/>	<input type="checkbox"/>
Condition columns.....	<input type="checkbox"/>	<input type="checkbox"/>	<input type="checkbox"/>

(mark here applicable, in case of verification mark in addition to the first mark!)

Security check carried out:.....

Carried out the company:.....

Name, address of the competent:.....

Result of the Check:

- Initiation not permitted, verification necessary
- Initiation possible, repair failures until.....
- No failings, Initiation possible

.....
signature of the expert

.....
signature of the operator

If failures must be repaired:

Failures repaired at:signature of the operator
(Use another form for verification!)