

## Operating instruction and documentation

Automotive lift date: 06/2017

Manual date: 02/2021

Original Instructions

UNI LIFT 3500 NT / 3500 NT PLUS  
HYMAX X 3500 PH / 3500 PH PLUS

Optional with SPID

Serial Nr.:

Art: 975395



## Table of contents

Foreword .....	4
Record of installation .....	6
Record of handing over .....	7
<b>1. Introduction.....</b>	<b>8</b>
1.1 Installation and check of the automotive lift .....	8
1.2 Information of Warning .....	8
<b>2. Master document of the automotive lift .....</b>	<b>9</b>
2.1 Lift–manufacturer .....	9
2.2 Application .....	9
2.3 Changes at the construction.....	9
2.4 Displacement of the automotive-lift .....	9
2.5 Declaration of conformity.....	10
<b>3. Technical information .....</b>	<b>11</b>
3.1 Technical ratings .....	11
3.2 Safety devices .....	11
3.3 Datasheet .....	12
3.4 Foundation plan.....	17
3.5 Dowel drilling pattern .....	27
3.6 Hydraulic diagram (without wheel free lift) .....	29
3.7 Hydraulic diagram (with wheel free lift) .....	31
3.8 Hydraulic diagram (with wheel free lift and play detector) .....	33
3.9 Electrical diagram drawing (without wheel free lift) .....	35
3.10 Electrical diagram drawing (with wheel free lift) .....	41
3.11 Electrical diagram SPID .....	47
<b>4. Safety regulations .....</b>	<b>53</b>
<b>5. Operating instructions .....</b>	<b>53</b>
5.1 Lifting the vehicle.....	53
5.2 Lowering the vehicle.....	54
5.3 Equalization of the platforms .....	54
<b>6. Troubleshooting .....</b>	<b>56</b>
6.1 Driving on an obstacle .....	57
6.2 Emergency lowering of the main lift/ wheel free lift .....	57
<b>7. Inspection and Maintenance .....</b>	<b>58</b>
7.1 Maintenance plan of the lift .....	58
7.2 Cleaning of the automotive lift .....	61
7.3 Cleaning and care of galvanised surfaces .....	61
Influence factors for discolourations of the surface .....	62
Touch-up after incidence of white rust: .....	62
Traces of usage due to tyre wear .....	62
Spotting due to spilling liquids .....	62
Cleaning and care .....	63
<b>8. Security check .....</b>	<b>63</b>
<b>9. Installation and Initiation .....</b>	<b>63</b>
9.1 Regulations for the installation .....	64
9.2 Erection and doweling of the lift .....	64
9.3 Deaerate the hydraulic system (main lift) .....	65
9.4 Initiation .....	66
9.5 Changing the installation place .....	66
First security check before installation .....	71
Regular security check .....	72
Extraordinary security check .....	84

## Foreword

Nussbaum-Lifts are a result of long-standing experiences.

The high quality and the superior concept guarantee them reliability, a long lift time and the economic business. To avoid unnecessary damages and dangers, read the operating instruction attentive and observe the contents. Another or the described purpose going out use is not valid when not as agreed. This is valid particularly for climb and go.

***Nussbaum Custom Lifts GmbH is not liable for damages arising from this. The user carries the risk alone.***

### For the use belonged:

- to observe all the notice in the operating instruction and
- the following of the inspection and maintenance work and the prescribed tests.
- The instruction for use have to be observed by all persons working with the lift.
- Especially the chapter "Safety/accident Prevention" has to be observed.
- In addition to the safety remarks of the instructions for use the regulations and instructions being valid at the place of operation have to be considered.

### Obligations of the operator:

The operator is obliged to allow only those persons complying to the following requirement to work at the unit

- being well acquainted with the basic regulations concerning labour safety and accident prevention and being trained to operate the unit.
- having read and understood the chapter concerning safety and warning instructions and confirmed that by their signature.

### Dangers when operating with the lift:

The Nussbaum-Lifts are designed and built according to technical standard and the approved regulations for technical security. Yet, danger for body and life of the operator may turn up when using the lift inexpertly.

### The lift must only be operated :

- for its appropriate use
- in unobjectionable condition concerning technical security.



### **Organising requirements**

- The instructions for use are constantly to be kept at the place of operation being at hand at any time.
- In addition to the instructions for use rules pertaining to other regulations i.e. accident prevention and environmental rules are to be observed and directed.
- Safety- and danger alert operation of personal is occasionally and by observing the instructions for use to be controlled.
- As far as required and ordered by regulations personal protective equipment is to be used
- All safety- and danger-hints at the lift are to be observed!
- Spare parts must comply with technical requirements laid down by the manufacturer. This is only warranted with original parts.  
Consider time intervals given or fixed in instructions for use for repeated tests/inspections.

### **Maintenance works, remedy of faults and disposal**

- Fixed Adjusting-, maintenance- and inspection works and time intervals including Details for exchange of parts/part components as mentioned in the instructions for use are to be adhered.  
These works must only be carried out by expert personal.
- After maintenance- and repair works loose screw connections must always be firmly tightened!

### **Guarantee and liability**

- Our „General conditions of selling and delivering“ are in force.  
There will be no guarantee or liability for injuries of persons or things if these injuries are caused by one or by some of the following reasons.
- Inappropriate use of the lift
- Inappropriate installation, initiation, operation and maintenance of the lift.
- Use of the lift while one or several security devices do not work or do not work correctly or are not installed correctly.
- Not to follow the regulations of the operating instruction concerning transport, storing, installation, initiation, operation and maintenance of the lift.
- Changes of the construction of the lift without asking the producer.
- Changes of important adjustments of the lift (e.g. driving elements, power rating, motor speed, etc)
- Wrong or incorrect maintenance.
- Catastrophes, acts of God or external reasons.



**Fill out, undersign and copy this sheet and send the original to the lift manufacturer. The copy remains in the manual.**

**Nussbaum Custom Lifts GmbH**

**Hertzstr. 6**

**D-77694 Kehl**

**Record of installation**

The automotive lift with the

serial number:..... was installed on:.....

at the firm:..... at:.....

The initial safety check was carried out and the lift was started.

The installation was carried out by the operating authority/competent (please delete as applicable).

The initial safety check was carried out by a competent person before the initial operation.

The operating authority confirms the correct installation of the automotive lift, the competent person confirms the correct initial operation.

Used Dowels(\*):.....(Type/Name)

Minimum anchorage depth (\*) kept: .....mm  ok

Starting torque (\*) kept: .....NM  ok

.....  
date name of the operating authority signature of the operating authority

.....  
date name of the competent person signature of the competent person

Your customer service:.....(stamp)

*(\*) see supplement of the dowel manufacturers*

Automotive Lift date: 06/2017 Manual date: 15.02.2021

### Record of handing over

The automotive lift with the

serial number:..... was installed on:.....

at the firm:..... at:.....

the safety was checked and the lift was started.

The persons below were introduced after the installation of the automotive lift. The introduction was carried out from an erector of the lift-manufacturer or from a franchised dealer (competent person).

.....  
date name signature

.....  
date name signature

.....  
date name signature

.....  
date name signature

.....  
date name signature

.....  
date name signature

.....  
date name of competent signature of the competent

Your customer service:.....

## 1. Introduction

The document "**Operating Instruction and Documentation**" contains important information about installation, operation and maintenance of the lift.

To furnish proof of the **installation of the automotive lift** the form "Record of Installation" must be signed and returned to the manufacturer.

To furnish proof of the singular, regular and extraordinary check this documentation contains forms. The forms should be used to document the checks. They should not be removed from this documentation.

Every **change of the construction** and **displacement** of the automotive lift has to be registered in the "**Master document**" of the lift.

### 1.1 Installation and check of the automotive lift

Only specialist staff is allowed to do work concerning safety and to do the safety checks of the lift. They are called experts and competent persons in this document.

Experts are persons (for example self-employed engineers, experts) which have received instruction and have experience to check and to test automotive lifts. They know the relevant regulations concerning both labour and accidents prevention.

Competent persons are persons who have acquired adequate knowledge and experience with automotive lifts. They took part in training from the lift-manufacturer (servicing technicians of the manufacturer or dealer are competent)

### 1.2 Information of Warning

To show danger and to show important information the three symbols below are used. Pay attention to those passages, which are marked with these symbols



***Danger! This sign indicates danger to life. Inexpert handling of the described operation may be dangerous to life.***



***Caution! This sign cautions against possible damage to the automotive lift or other material defects in case of inexpert handling .***



***Attention! This sign indicates an important function or another important note.***

## 2. Master document of the automotive lift

### 2.1 Lift–manufacturer

Nussbaum Custom Lifts GmbH  
Hertzstr. 6  
D-77694 Kehl

### 2.2 Application

The automotive lift UNI-LIFT 3500 NT / Plus / Spid is a lifting mechanism for lifting motor vehicles with a laden weight of up to 4000 kg (with wheel free lift 3500 kg). The max. load distribution is 2:1 in or against drive-on direction.

The wheel free lift is a lifting mechanism for lifting motor vehicles with a laden weight of up to 3500 kg. The max. load distribution is 2:1 in or against drive-on direction.

The lift is equipped with a detector (called SPID) which is able to detect play in the axes and on single wheel suspensions. The detection is possible up to an axle load of 2300 kg.

The automotive lift is only designed for servicing vehicles. It is not allowed to carry persons with the lift. It is not allowed to climb on the lift or on the vehicle. It's not allowed to install the standard-automotive lift in a hazardous location or washing bays.

After changes of the construction and after essential maintenance work on carrying parts and after changing the installation place, an expert has to check the lift and to confirm its correctness and security.

### 2.3 Changes at the construction

#### Changes at the construction, expert checking, resumption of work

(date, kind of change, signature of the expert)

.....  
.....  
.....

name, address of the expert

.....  
place, date

.....  
signature of the expert

### 2.4 Displacement of the automotive-lift

#### Displacement of the automotive-lift, expert checking, resumption of work

(date, kind of change, signature of the expert)

.....  
.....  
.....

name, address of the expert

.....  
place, date

.....  
signature of the expert

## 2.5 Declaration of conformity

### EG- Konformitätserklärung



gemäß Maschinenrichtlinie Anhang II 1A

Declaration of Conformity according Machinery Directive 2006/42/EG ANNEX II 1A  
Déclaration de conformité selon directive machines annexe II 1A  
Declaración de conformidad según Directiva Maquinaria 2006/42/EG ANNEX II 1A  
Dichiarazione di conformità in accordo alla direttiva 2006/42/EG ANNEX II 1A

Hiermit erklären wir, daß die Hebebühne, Modell:  
Hereby we declare that the lift model:  
Par la présente nous déclarons que le pont élévateur modèle  
Por la presente declara, que el elevador modelo:  
Con la presente si dichiara che il sollevatore:

UNI LIFT 3500 NT  
UNI LIFT 3500 NT PLUS  
  
HYMAX X 3500 PH  
HYMAX X 3500 PH PLUS

allen einschlägigen Bestimmungen der folgenden Richtlinien entspricht:  
fulfils all the relevant provisions of the following Directives:  
correspond aux normes suivantes:  
cumple todas las disposiciones pertinentes de las Directivas siguientes:  
adempie a tutte le richieste delle seguenti direttive:

Maschinenrichtlinie / Machinery Directive	2006/42/EG
EMV Richtlinie / EMC Directive	2014/30/EU
Niederspannungsrichtlinie / Low Voltage Directive	2014/35/EU

in Übereinstimmung mit den folgenden harmonisierten Normen gefertigt wurde  
was manufactured in conformity with the harmonized norms  
fabriqué en conformité selon les normes harmonisées en vigueur.  
producido de acuerdo a las siguientes normas armonizadas.  
è stato fabbricato in conformità con le norme armonizzate

Fahrzeug- Hebebühnen / Vehicle lifts	EN 1493: 2010
--------------------------------------	---------------

Beauftragter für die Technische Dokumentation Authorised to compile the technical file	Nussbaum Custom Lifts GmbH
---	----------------------------

Baujahr Year of manufacture	20__
--------------------------------	------

Seriennummer Serial number	_____
	Seriennummer

Kehl- Sundheim, 15.07.2020

  
Steffen Nollbaum  
Geschäftsführer

DoC-NCL\_UNILIFT-3500-NT-PLUS\_2020-07



Nussbaum Custom Lifts GmbH | Hertzstraße 6 | 77694 Kehl-Sundheim |



### 3. Technical information

#### 3.1 Technical ratings

capacity without wheel free lift	4000 kg
with wheel free lift	3500 kg
load distribution	max. 2:1 in or against drive-on direction
Lifting time (main lift)	approx. 30 sec. with load
Lowering time (main lift)	approx. 30 sec. with load
capacity wheel free lift	3500 kg
load distribution	max 2:1 in or against drive- in-direction
Lifting time (wheel free lift)	approx. 5 sec. with load
Lowering time (wheel free lift)	approx. 12 sec. with load
capacity detector „SPID“	max. axle load 2300 kg
Line Volthage	3 x 400 Volt , 50Hz
Power rating	3 kW
Motor speed	3000 rot./min.
Pump capacity	3 cm <sup>3</sup> /rot.
Hydraulic pressure	ca. 270 bar
pressure relief valve	ca. 300 bar
Oil tank	approx. 14 Litre
Sound level L <sub>PA</sub>	≤ 70 dB
Connection by customer	3~/N+PE, 400V, 50 Hz (standard version) with fuse T16A (Pay attention to the voltage of your country)

#### 3.2 Safety devices

1. Pressure relief valve  
Overprint-safety of the hydraulic system
2. Holding valve  
safety device against unintentional lowering
3. Lockable main switch  
safety device against unauthorised operation
4. Foot protection  
safety device against bruises in the area of the feet
5. Two independent cylinders  
(each side master- and slave-cylinder)  
safety device against unintentional lowering
6. Seat valves at the cylinders of the wheel free lift  
safety device against unintentional lowering of the wheel free lift
7. CE-STOP  
safety device against squeeze

**3.3 Datasheet**

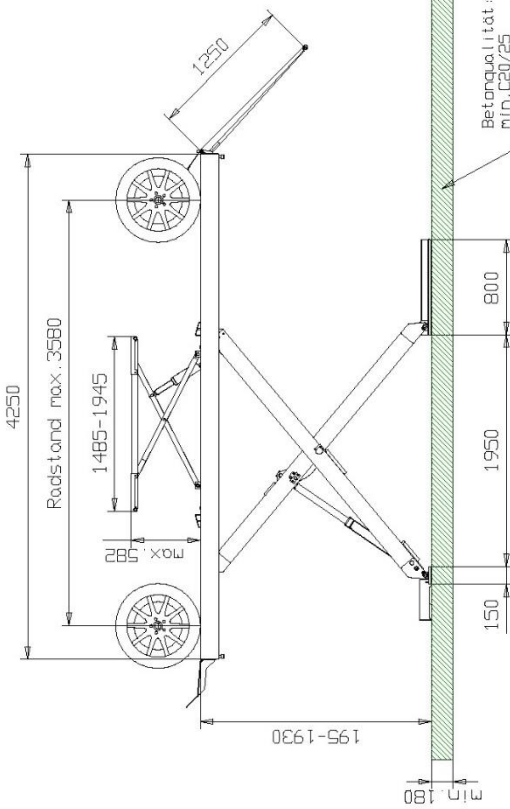

Radstrecke max. 3580  
1485-1945  
max. 582  
195-1930  
4250  
1950  
800  
min. 180

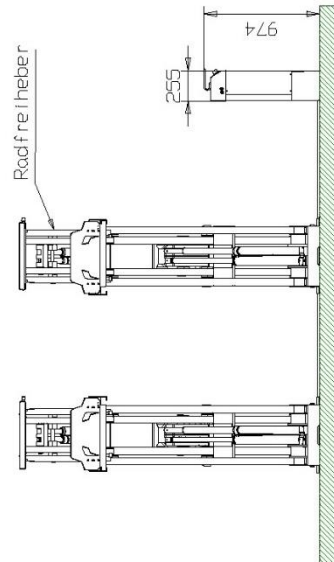

Radfahreheber  
974  
255

Betonqualität: min. C20/25 normal bewehrt.

Tragfähigkeit: Hebebühne 3500kg, Radfahreheber 3500kg

Die Position des Bedienagregates kann den örtlichen Gegebenheiten angepasst werden, ggf. sind die Versorgungsleitungen, Kabelkanäle zu verlängern.

Bei Bestellung ist der Einbau-, Fundamentplan beizulegen oder die Zeichnungsnummer immer anzugeben.

Mir weisen in unseren Plänen auf die Mindestanforderung des Fundamentes hin, jedoch der Zustand der örtlichen Gegebenheiten (z.B. Untertur) obliegt nicht unserer Verantwortung. Im Bedarfsfall ist ein Architekt, Statiker hinzuzuziehen.

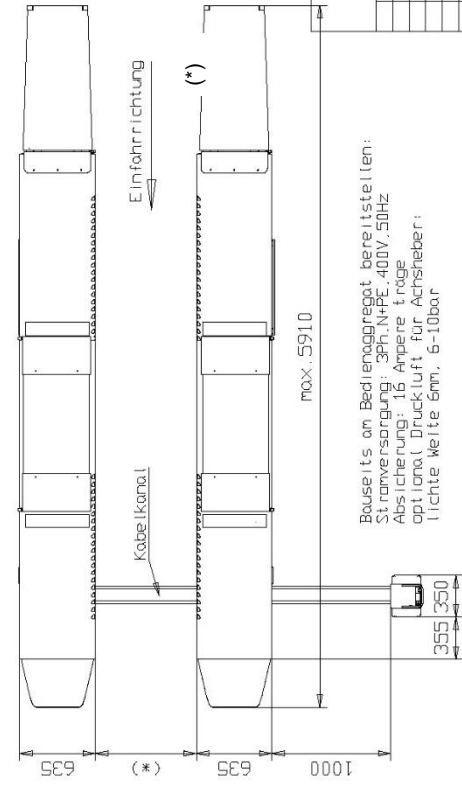

Einrichtung (\*)  
Kabelkanal  
max. 5910  
1000  
355, 350

Boards als Bedienagregat bereithalten:  
Stromversorgung 3Ph.N/PE, 400V, 50Hz  
Absicherung: 16 Ampere träge  
optimal Druckluft für Achsheber:  
lichte Weite 6mm, 6-10bar

MöB- und Konstruktionsänderungen vorbehalten!

Messwerte / Toleranzen			Messstab:			Gewicht:		
Maß	ohne Toleranzen	Angabe	Werkstoff	Halbzeug		kg		
Datum	Verf.	Urspr.	–	–		–		
Beib.	29.04.11	M.G.	Bezeichnung			UNI-LIFT 3500 NT PLUS		
Verf.			Schienerlänge			4200mm		
Name			Zeichnungsnummer			7139-1-NB		
Nussbaum			Ersatz durch:			Blatt von		



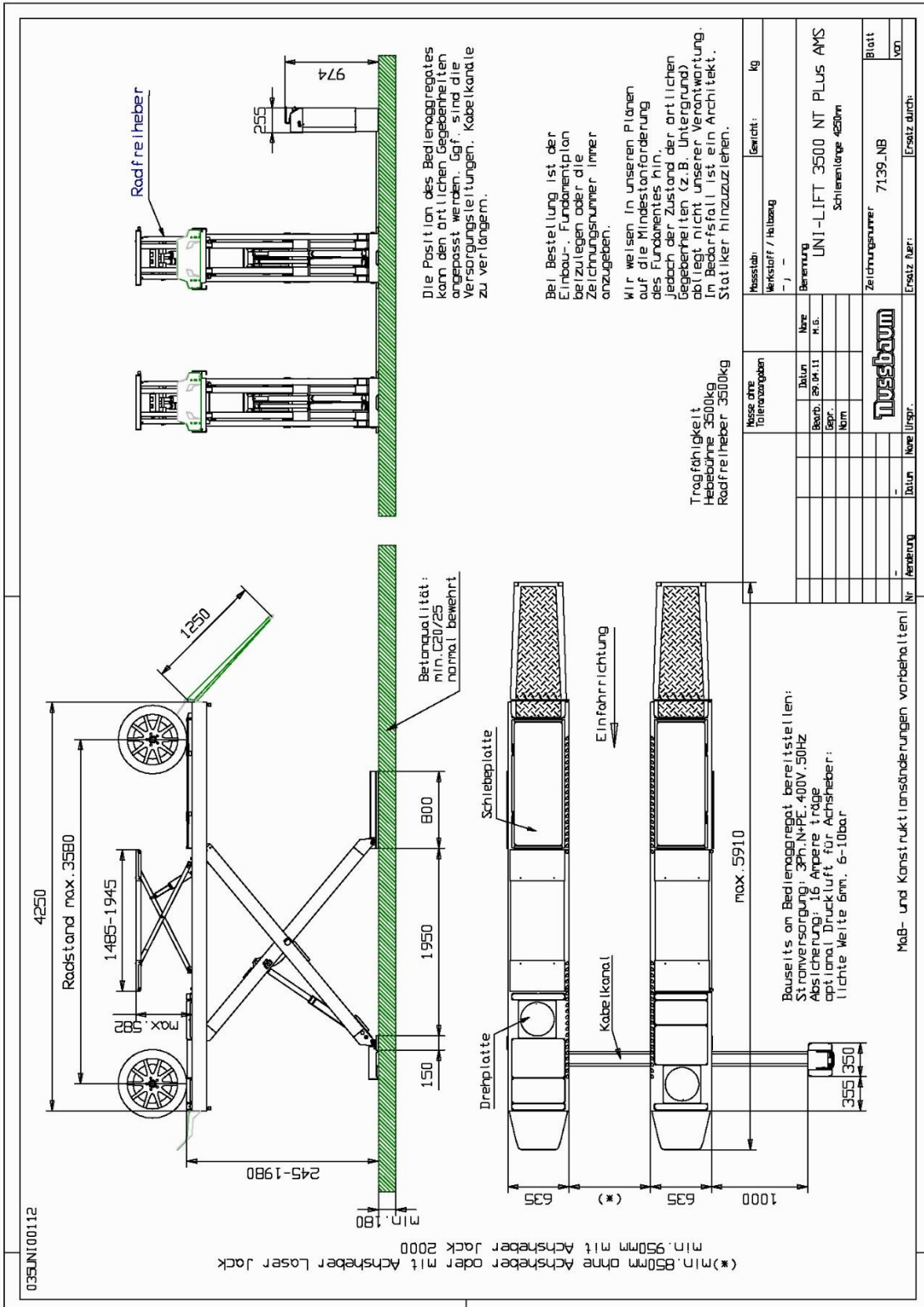

Technical data:

- Tragfähigkeit : 4000 kg
- Aufhöhe : 195 mm
- Aufstiegszeit : 1.920 mm
- Hubzeit max. : ca. 31 sec
- Senkzeit : ca. 19 sec
- Motorleistung : 3 kW

(\* ) min 850mm ohne Achsheber  
min 950mm mit Achsheber

Radstand max. 4050

max. 1920

min. 195

830

639

639

405

4500

6155

1250

Alle Masse in mm.  
Mass- und Konstruktionsänderungen vorbehalten.  
Der genaue Lieferumfang ist der Preisliste zu entnehmen.

Datenblatt UNI LIFT 3500 NT

30.08.2000 / Veid

2216-1 EINBAU

**Nussbaum**  
**HEBETECHNIK**  
TEL: +49 30 639 11 11  
WWW.NUSSBAUM-LIFTS.DE  
77694 KEHL-BODERSWEILER

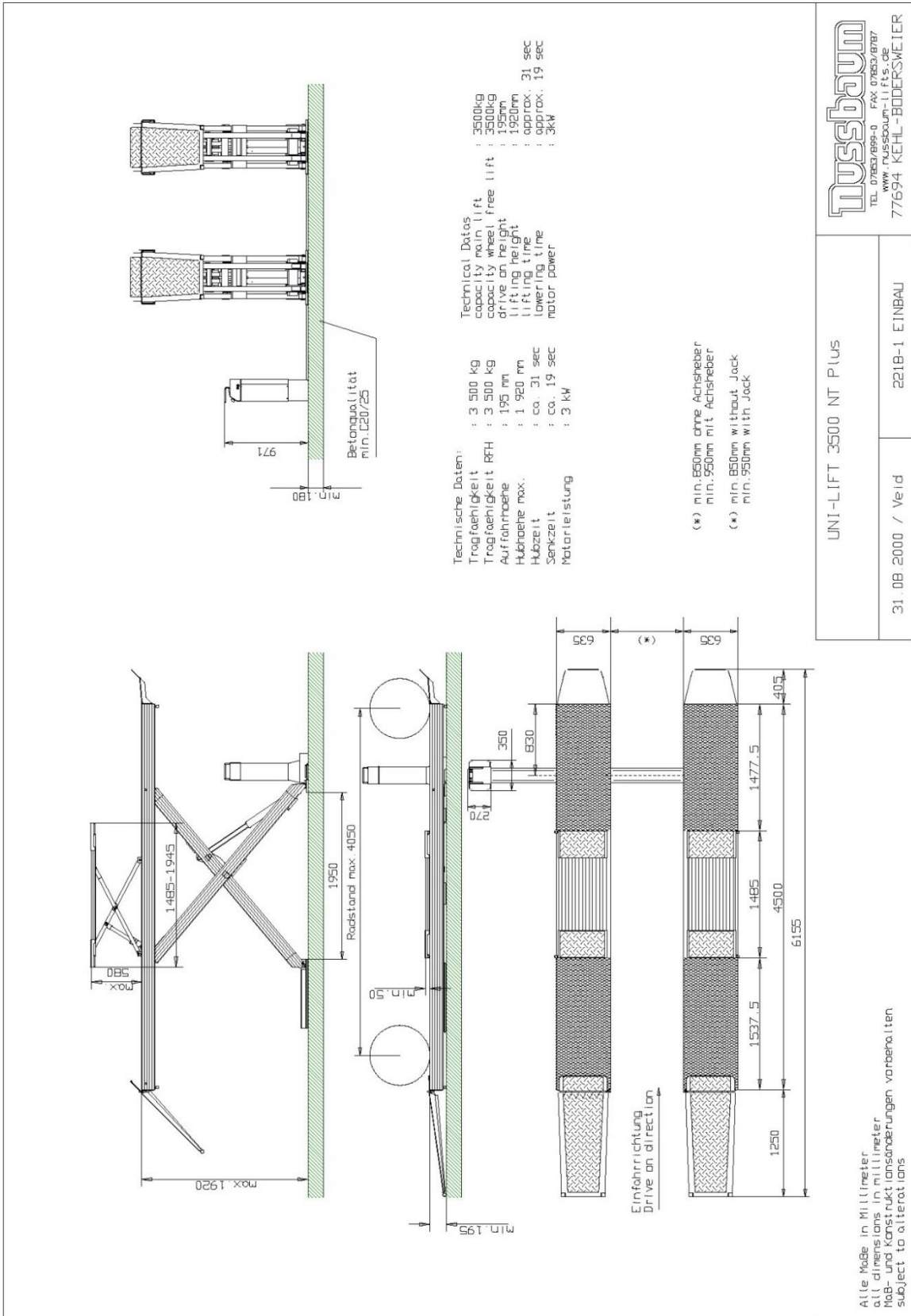

**Nussbaum**  
TELEFON: 089 999-0 FAX: 089 999-07  
WWW.NUSSBAUM.LIFTS.COM  
77694 KEHL-BODERSWEILER

UNI-LIFT 3500 NT PLUS	
31.08.2000 / Verid	221B-1 EINBAU

Alle Maße in Millimeter  
all dimensions in millimeter  
Maß- und Konstruktionsänderungen vorbehalten  
subject to alterations

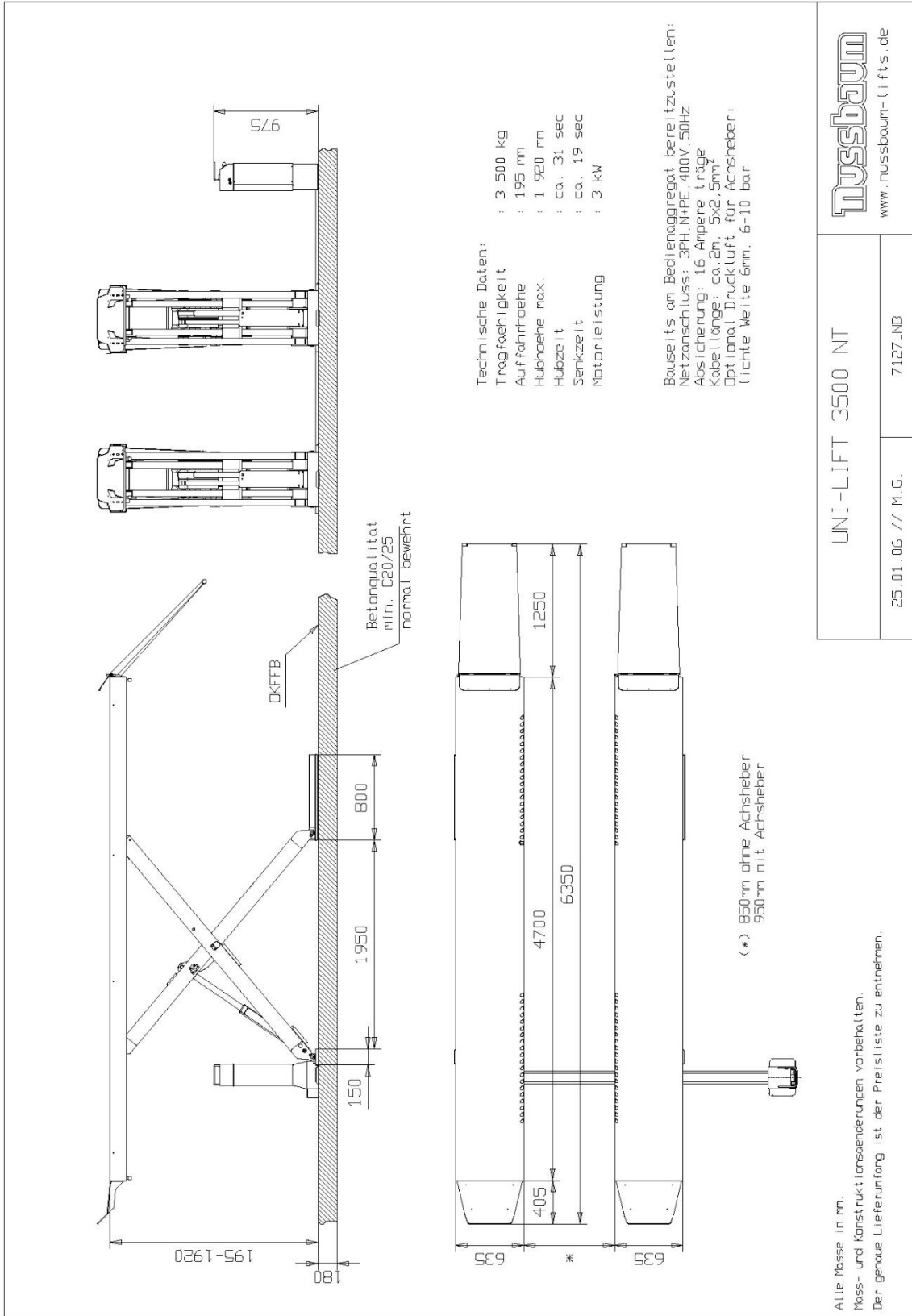



**3.4 Foundation plan**

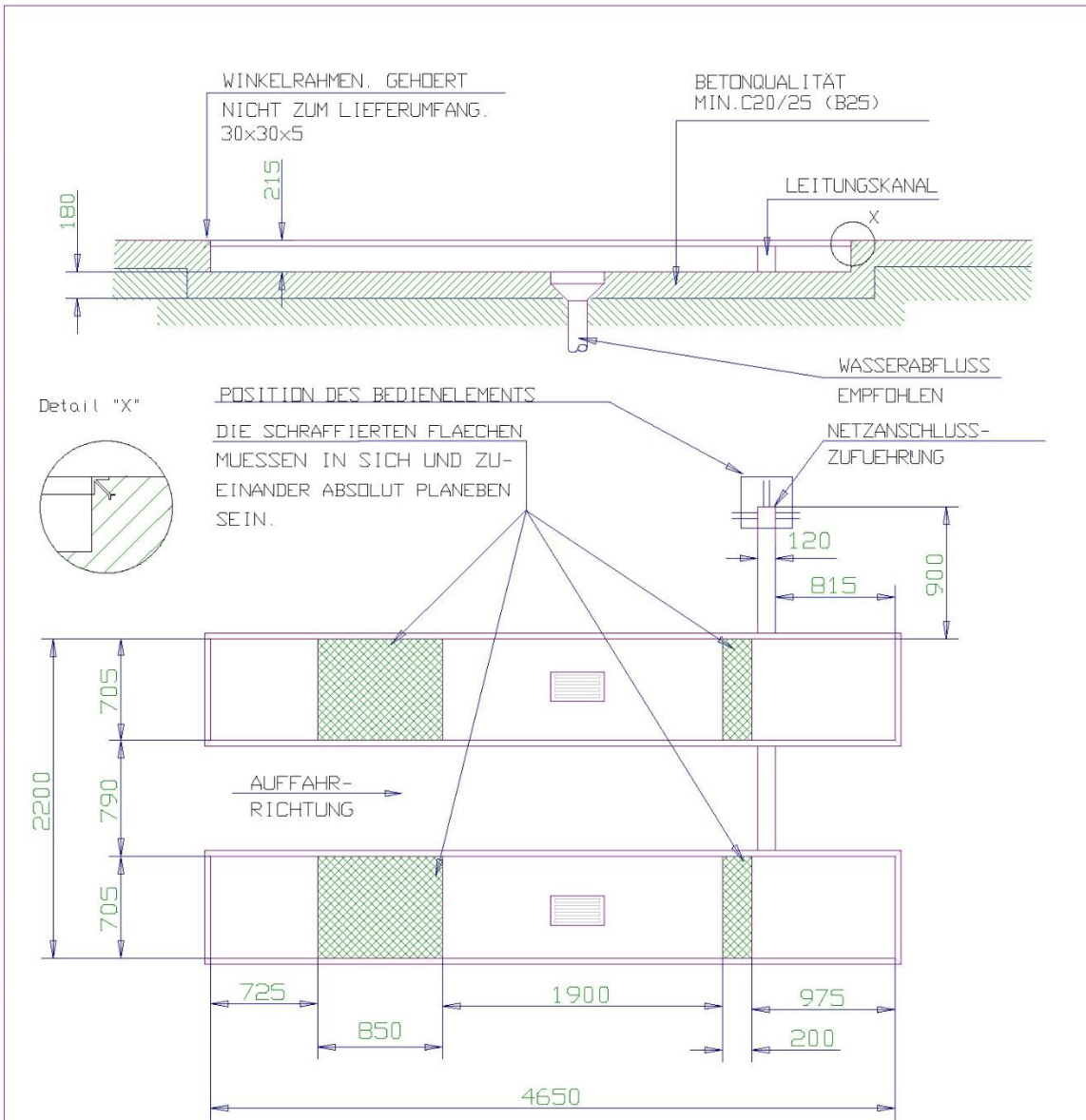

ACHTUNG: GILT NUR FÜR DIE SERIENAUSFÜHRUNG MIT STELLPLATTEN UND  
BEIDSEITIGEN AUFFAHRKLAPPEN.  
ANSTELLE DES LEITUNGSKANALS KANN AUCH EIN LEERROHR  
Ø 100 VERLEGT WERDEN.

BAUSEITS IST FOLGENDES ANZUBRINGEN: NETZANSCHLUSS 3 /N+PE, 400V, 50Hz, KABELLÄNGE CA. 2m  
WASSERABFLUSS IN DER VERTIEFUNG

Änderungen vorbehalten/ Subject to alterations!

GRUBENMASSE UNI-LIFT 3500 CLT / NT

ÜBERKANTE AUFFAHRSCHEITNE BODENEBCN, SCHEITNENLÄNGE 4 500 MM

29.09.2000 / M.A

EINBAU2226

**Nussbaum**

TEL 07853/899-0 FAX 07853/8787  
www.nussbaum-lifts.de

77694 KEHL-BODERSWEIER

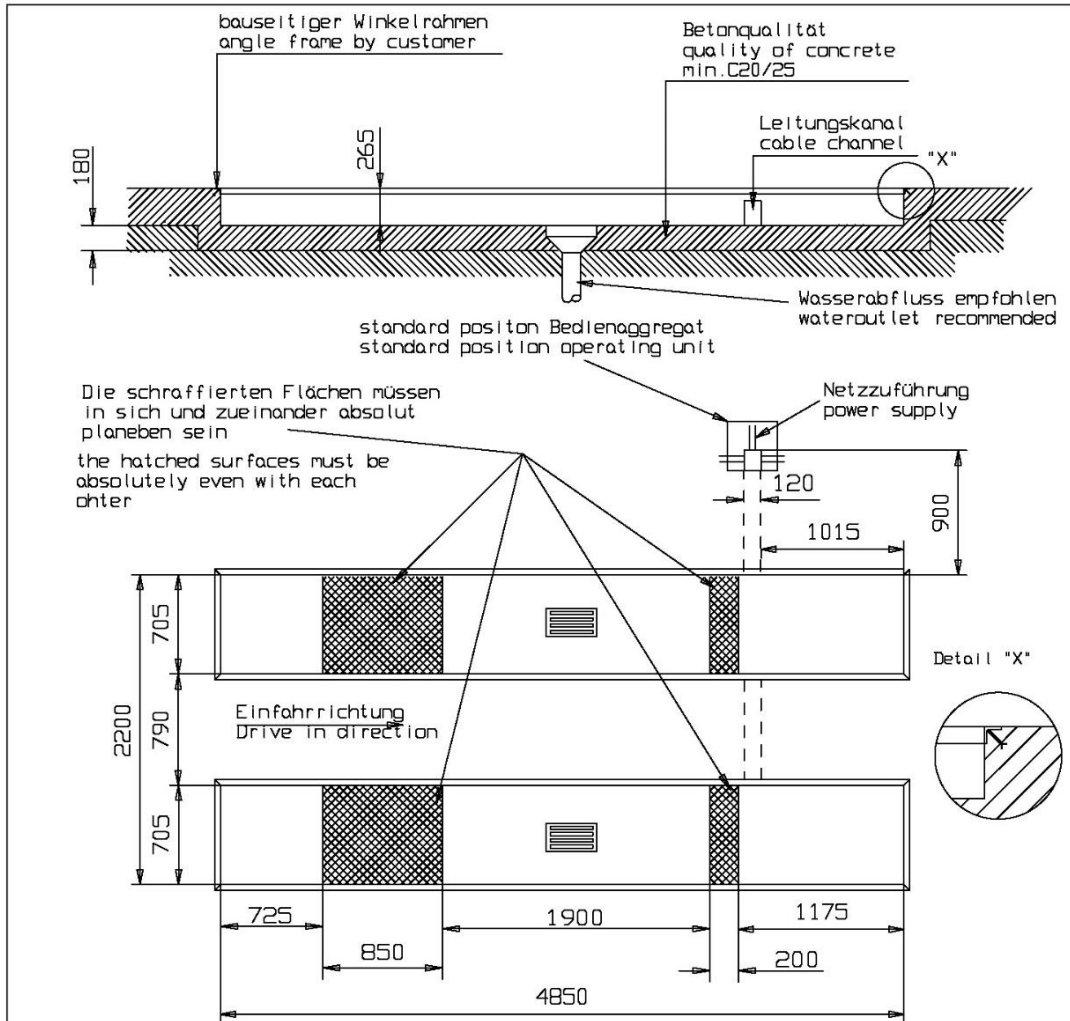

Die schraffierten Flächen müssen in sich und zueinander absolut planeben sein  
the hatched surfaces must be absolutely even with each other

Gültig für die Serienausführung mit Stellplatten und beidseitigen Auffahrklappen  
Bauseits am Bedienaggregat bereitstellen:  
Stromversorgung: 3PH,N+PE, 400V, 50Hz  
Absicherung: 16 Ampere träge  
Druckluft optional für Achsheber: lichte Weite 6mm, 6-10bar  
Valid for standard version with baseplates and drive on ramps at each side of the platform  
Prepared at the operating unit by customer:  
Electrical power supply: 3PH,N+PE, 400V, 50Hz  
Fuse: 16A time-lag fuse  
Air pressure optional for Jack: 6mm wide, 6-10bar

Wir weisen in unseren Plänen auf die Mindestanforderung des Fundamentes hin, jedoch der Zustand der örtlichen Gegebenheiten (z.B. Untergrund) obliegt nicht unserer Verantwortung. Im Bedarfsfall ist ein Architekt, Statiker hinzuzuziehen.

We point out the minimum requirement of the foundation in our plans. The condition of the local realities (for example: ground under the foundation) does not lie our responsibility. If necessary an architect must be consulted.

Die Position des Bedienaggregates kann den örtlichen Gegebenheiten angepasst werden. Ggf. sind die Versorgungsleitungen anzupassen.

The Position of operating unit can be changed. If necessary the feeding lines must become extended.

Änderungen vorbehalten/ Subject to alterations!

Fundamentplan UNI LIFT NT / CLT		<b>Nussbaum</b> www.nussbaum-lifts.de
Oberkante Achsmesset bodeneben, Schienenlänge 4700 Wheel alignment flat with floor, platform length 4700mm		
29.09.2000 / M.A.	2226-1 EINBAU	

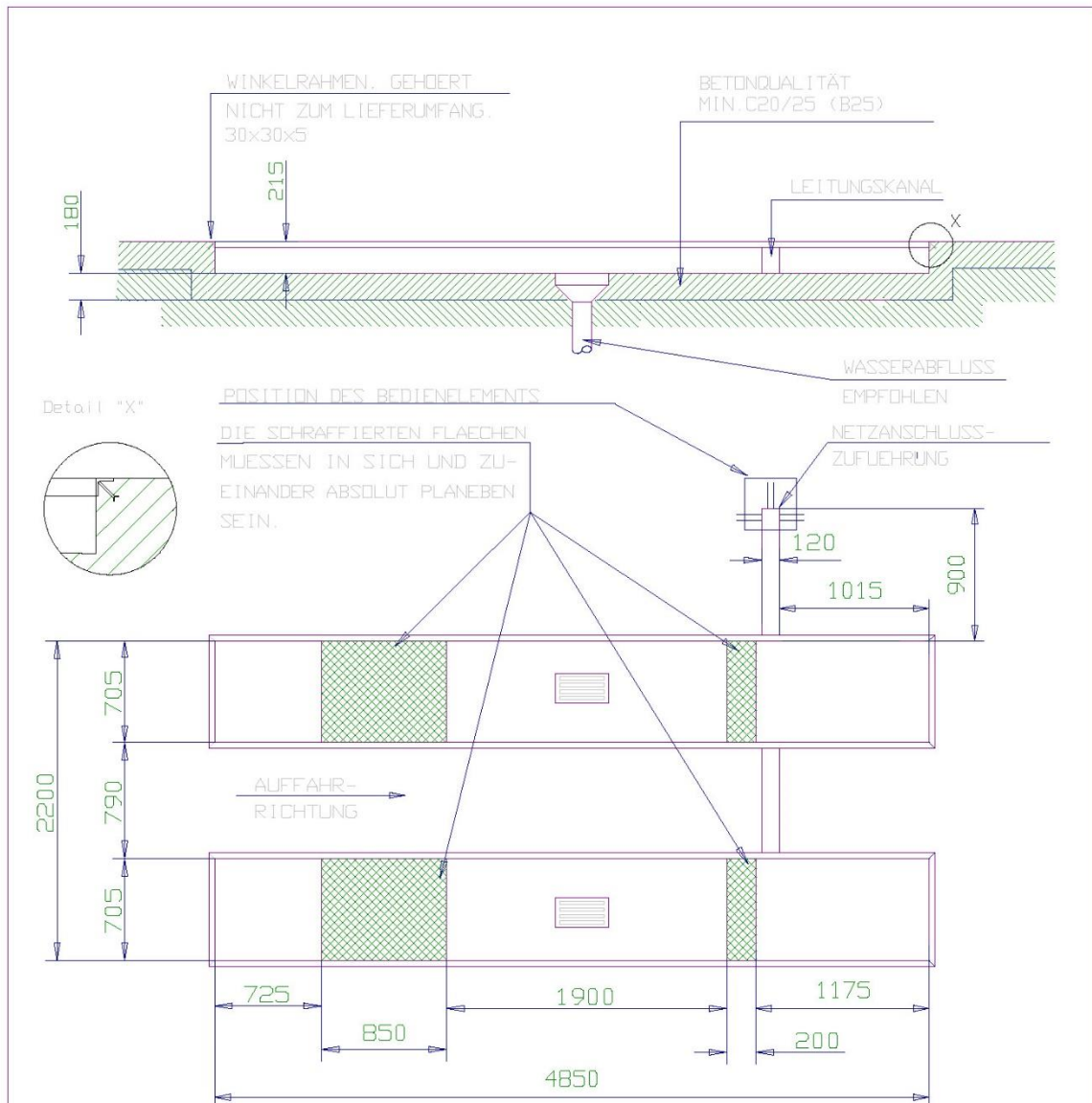

ACHTUNG: GILT NUR FÜR DIE SERIENAUSFÜHRUNG MIT STELLPLATTEN UND  
BEIDSEITIGEN AUFFAHRKLAPPEN.  
ANSTELLE DES LEITUNGSKANALS KANN AUCH EIN LEERROHR  
Ø 100 VERLEGT WERDEN.

BAUSEITIS IST FOLGENDES ANZUBRINGEN: NETZANSCHLUSS 3 /N+PE, 400V, 50Hz, KABELLAENGE CA. 2m  
WASSERABFLUSS IN DER VERTIEFUNG

Änderungen vorbehalten/ Subject to alterations!

GRUBENMASSE UNI-LIFT 3500 CLT / NT  
Oberkante Auffahrschiene bodeneben, Schienenlänge 4700mm

29.09.2000 / M.A.

2226-2\_EINBAU

**Nussbaum**

TEL 07853/899-0 FAX 07853/8787  
www.nussbaum-lifts.de

77694 KEHL-BODERSWEIER

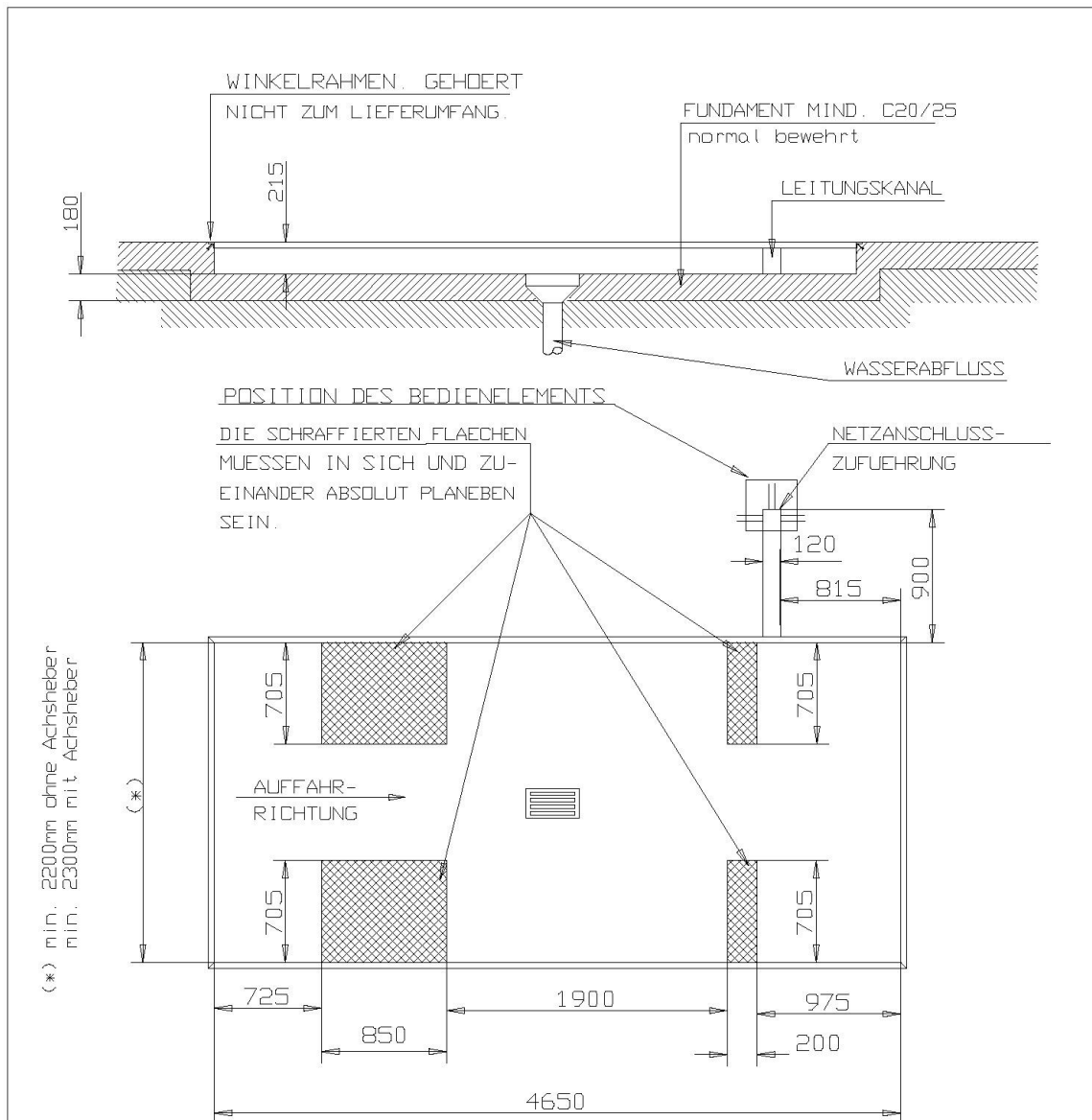

ACHTUNG: GILT NUR FUER DIE SERIENAUSFUEHRUNG MIT STELLPLATTEN UND BEIDSEITIGEN AUFFAHRKLAPPEN.  
ANSTELLE DES LEITUNGSKANALS KANN AUCH EIN LEERROHR  
Ø 100 VERLEGT WERDEN.

BAUSEITS IST FOLGENDES ANZUBRINGEN: NETZANSCHLUSS 3 /N+PE, 400V, 50Hz, KABELLAENGE CA. 2m  
WASSERABFLUSS IN DER VERTIEFUNG

GRUBENMASSE UNI-LIFT 3500 CLT / NT  
mit durchgehender Grube fuer Achsheber, Oberkante Auffahrschiene bodeneben.  
Schienenloenge 4 500 mm

04.10.2000 / M.A

EINBAU2227

**NUSSBAUM**  
**HEBETECHNIK**

FERTIGUNGSTECHNIK + MASCHINENBAU  
77694 KEHL-BODERSWEIER



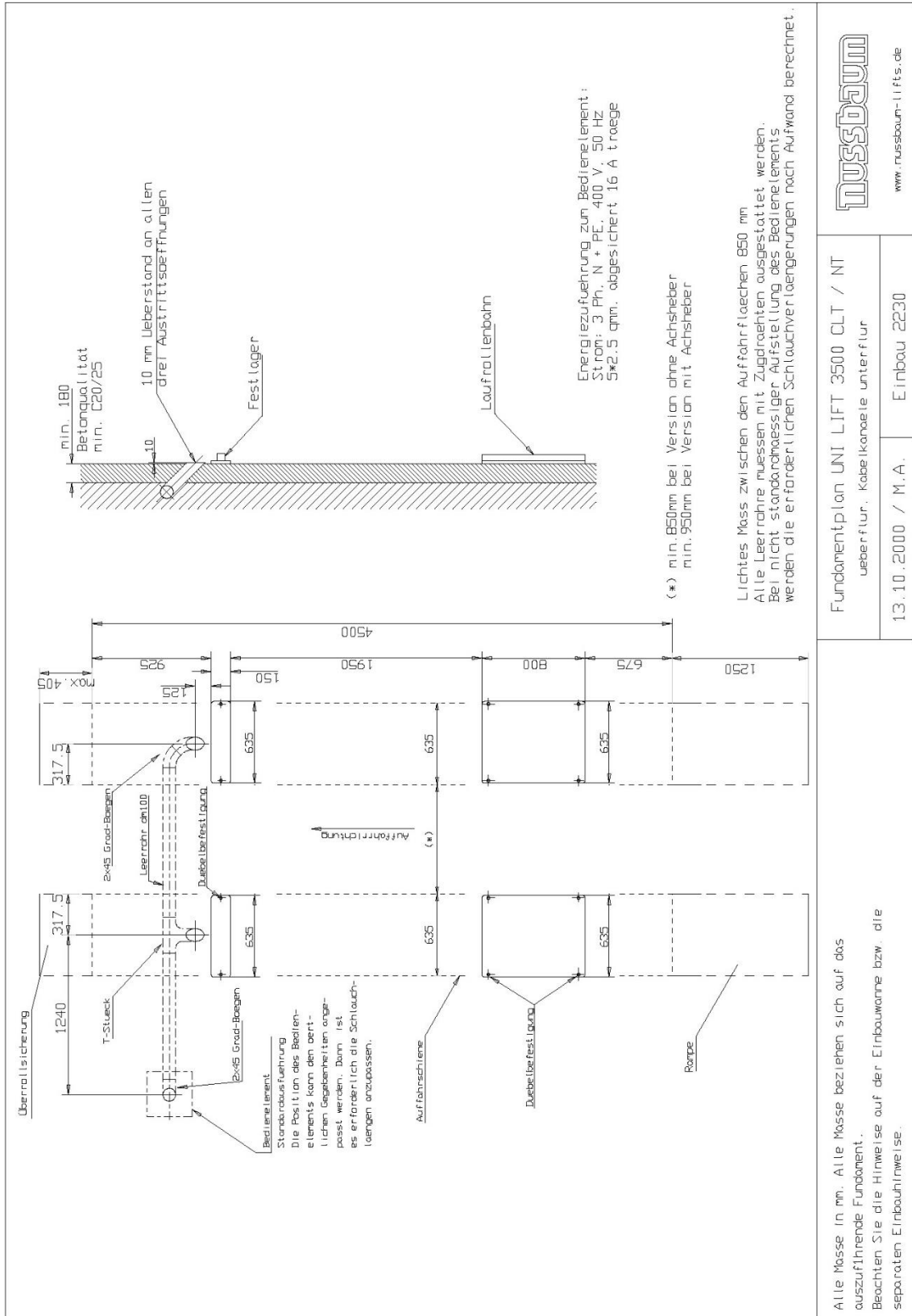

www.nussbaum-lifts.de

Fundamentplan UNI LIFT 3500 CLT / NT  
überflur, Kabe lkanäle unterflur  
13.10.2000 / M.A. Einbau 2230

Alle Masse in mm. Alle Masse beziehen sich auf das auszuführende Fundament.  
Beachten Sie die Hinweise auf der Einbauwanne bzw die separaten Einbauhinweise.

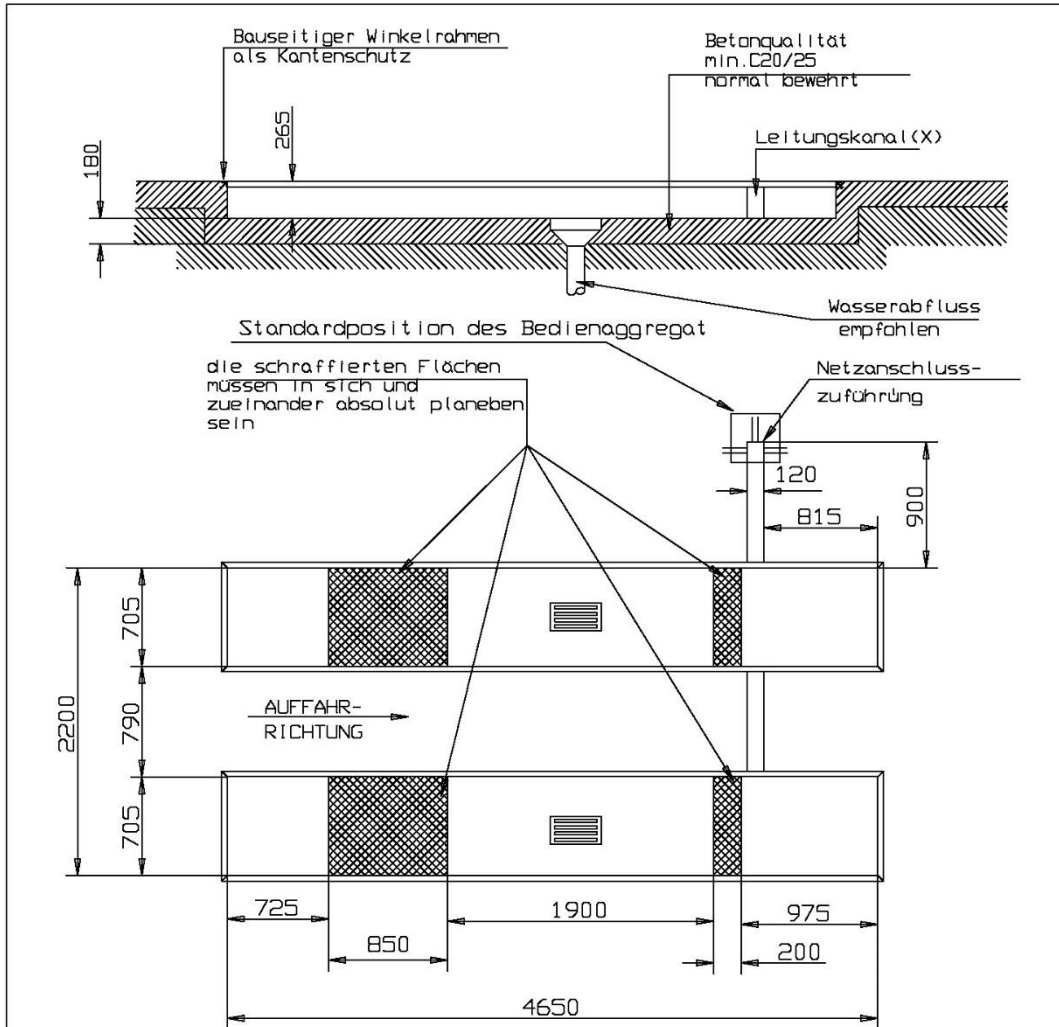

**ACHTUNG:**  
Gültig nur für die Serienausführung mit Fest- und Lastlager und beidseitigen Auffahrklappen.  
Anstelle des Leitungskanals kann auch ein Leerrohr min. DN100 verlegt werden.

Bauseits am Bedienelement bereitstellen:  
Netzanschluss: 3PH, N+PE, 400V, 50Hz  
Absicherung: 16 Ampere träge

(X) alternative zum Leitungskanal

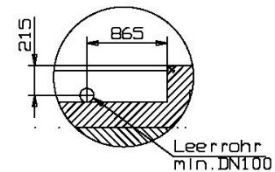

Alle Masse in mm. Alle Masse beziehen sich auf das auszuführende Fundament. Beachten Sie die Hinweise auf der Einbauwanne bzw. die separaten Einbauhinweise.

UNI-LIFT 3500 NT/CLT Plus AMS Streifenfundament, Oberkante Achsmess- Set bodeneben.	
25.10.2000 / M.A.	Einbau 2232

**Nussbaum**  
www.nussbaum-lifts.de

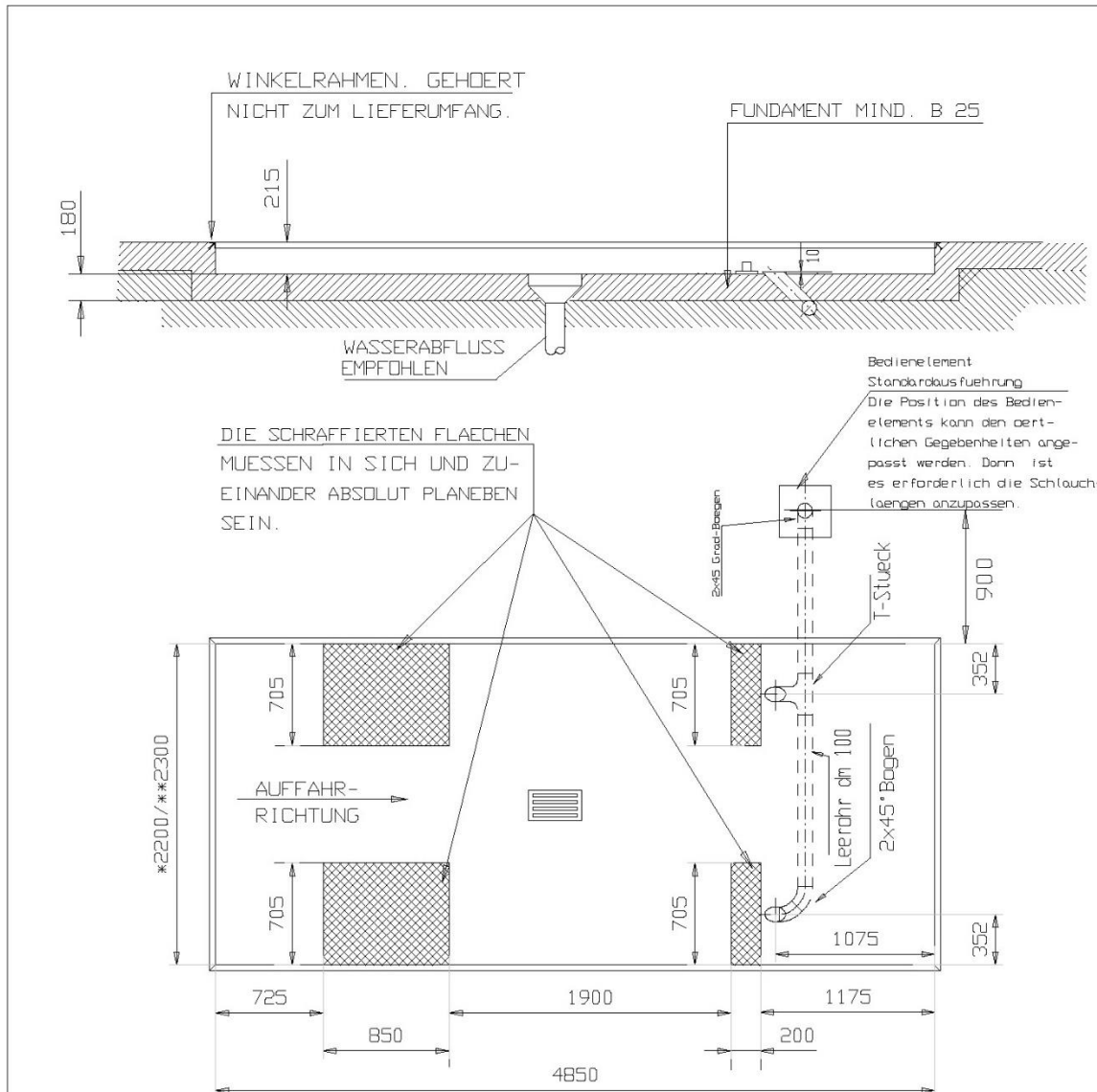

\* Version ohne Achsheber  
 \*\* Version mit Achsheber

ACHTUNG: GILT NUR FÜR DIE SERIENAUSFÜHRUNG MIT STELLPLATTEN UND BEIDSEITIGEN AUFFAHRKLAPPEN.  
 ANSTELLE DES LEITUNGSKANALS KANN AUCH EIN LEERROHR dm 100 VERLEGT WERDEN.

BAUSEITIGS IST FOLGENDES ANZUBRINGEN: NETZANSCHLUSS 3 /N+PE, 400V, 50Hz, KABELLÄNGE CA. 2m  
 WASSERABFLUSS IN DER VERTIEFUNG

Fundamentplan UNI LIFT 3500 CLT / NT Komplettfundament (für Achsheber) Oberkante Auffahrtschiene bodeneben. Kabelkanäle unterflur, Schienenlänge 4700 mm		 TEL 07853/899-0 FAX 07853/8787 FERTIGUNGSTECHNIK + MASCHINENBAU 77694 KEHL-BODERSWEIER
16.03.06 // M.G.	3016-1 EINBAU	

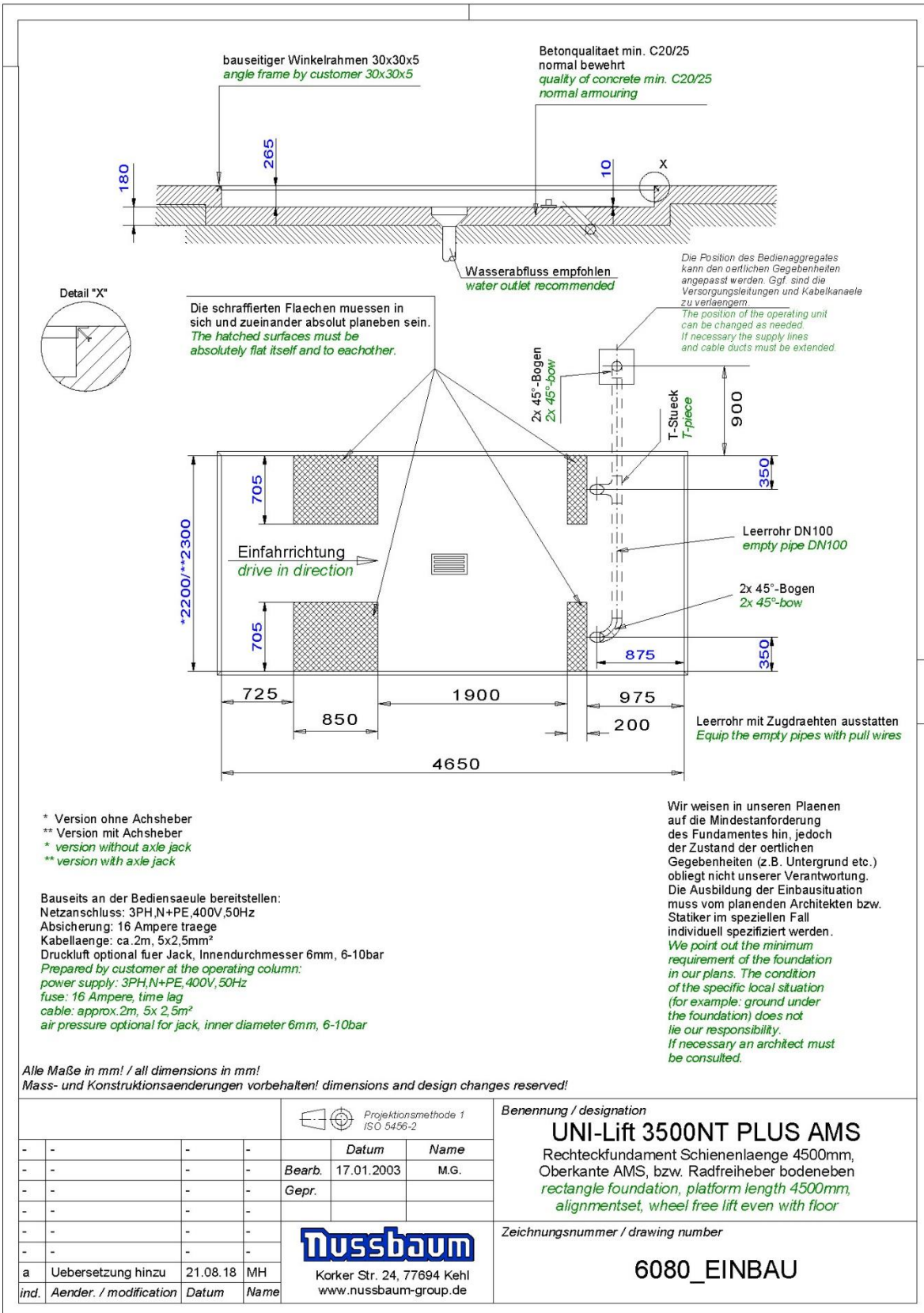



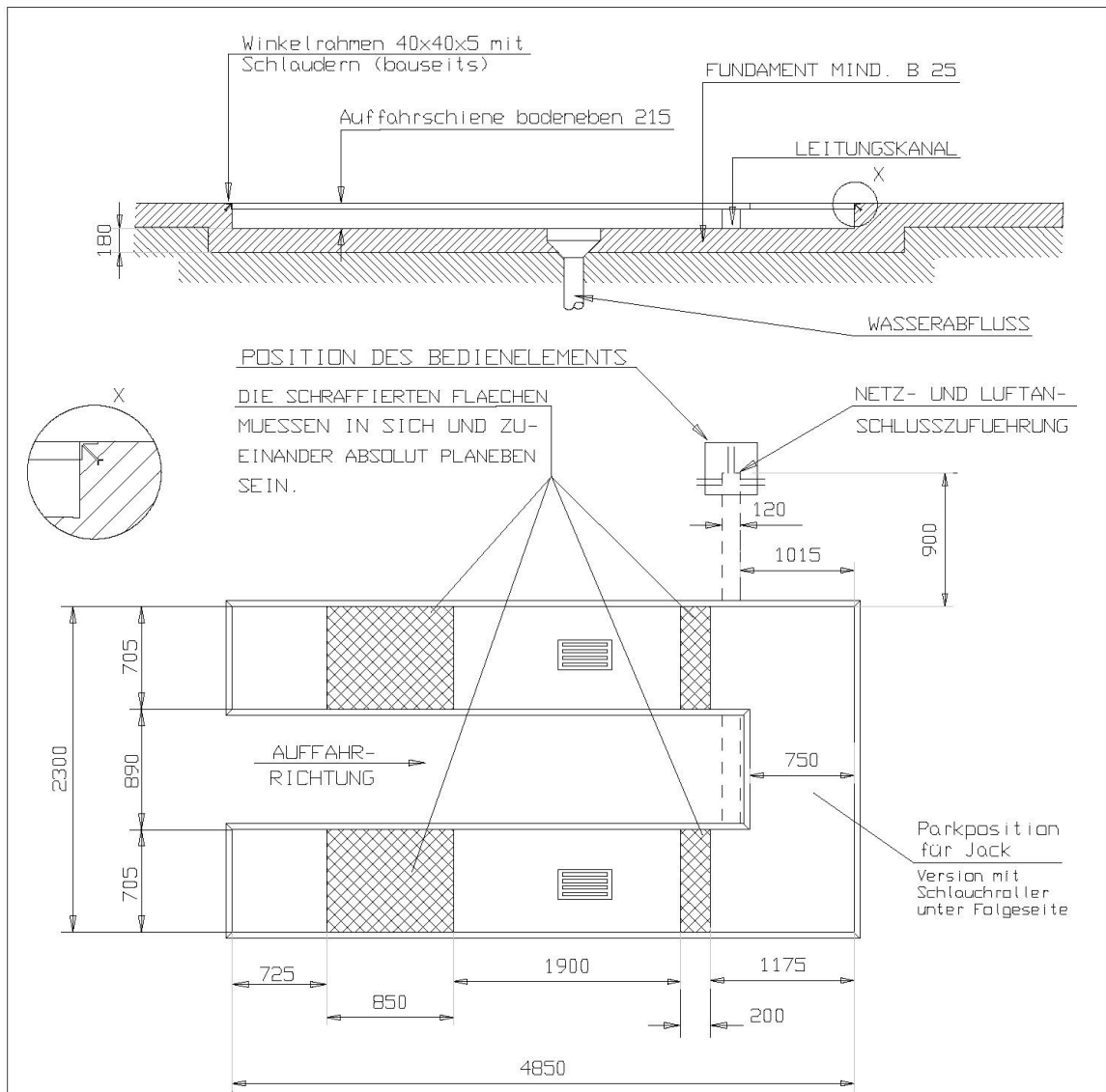

ACHTUNG: GILT NUR FUER DIE SERIENAUSFUERUNG MIT STELLPLATTEN UND BEIDSEITIGEN AUFFAHRKLAPPEN.  
ANSTELLE DES LEITUNGSKANALS KANN AUCH EIN LEERROHR  $\varnothing$  100 VERLEGT WERDEN.

Bauseits ist am Bedienteil folgendes bereitzustellen:  
Für ausreichende Länge der Versorgungsleitungen ist zu sorgen.  
Netzanschluss 3/N+PE, 400 V, 50 Hz.  
Luftanschluss lichter Durchmesser 6mm, Druck 6 bar  
Wasserabfluss in der Vertiefung.

Alle Masse in mm. Änderungen vorbehalten!

Fundamentplan UNI-LIFT 3500 CLT/NT

Ohne Radfreiheber Parkposition für Jack  
Ohne Achsmeßset mit Schlauchroller Schiene 4700 mm

12.02.03 // M.G.

6089 EINBAU

**Nussbaum**

TEL 07853/899-0 FAX 07853/8787  
www.nussbaum-lifts.de  
77694 KEHL-BODERSWEIER









**3.6 Hydraulic diagram (without wheel free lift)**

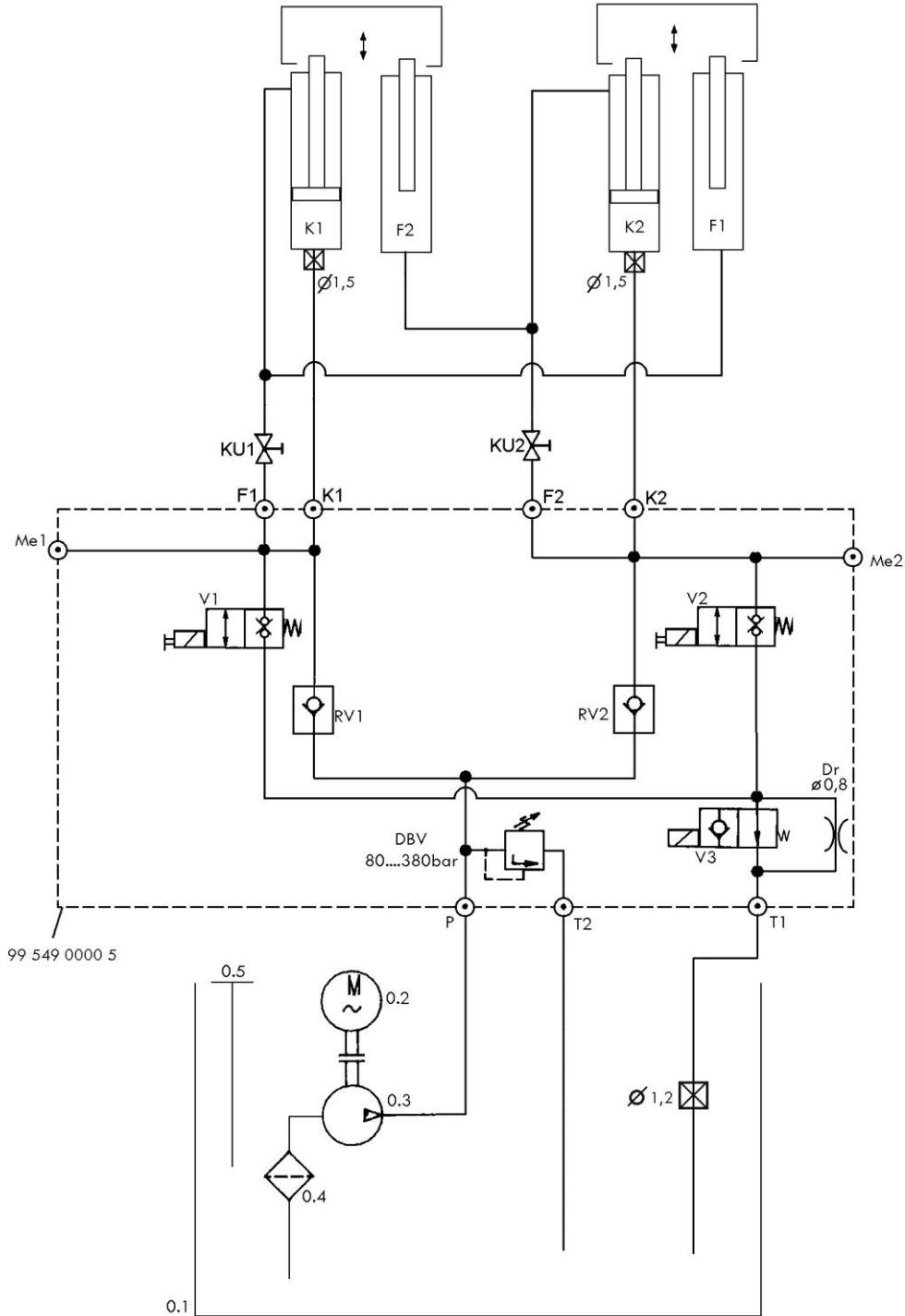

Stand 04-01  
H-Plan UNI NT 04-01.jpg

### Hydraulic parts list

<b>Nr.</b>	<b>description</b>	<b>order number</b>
0.1	oil tank	
0.2	motor	992856
0.3	gear pump	980340
0.4	sub oil filter	980012
0.5	oil level gauge	980098
RV1	holding valve	980480
RV2	holding valve	980480
DBV	pressure control valve	155211
V1	double seat valve (manual unlocking)	600001
V2	double seat valve (manual unlocking)	600001
V3	seat valve (manual unlocking)	159318
DR	regulating valve Ø 0,8	
Me1	measuring connection	155470
Me2	measuring connection	155470
KU1	ball valve	980513
KU2	ball valve	980513
K1	master cylinder 1	pair of cylinders complete 035UNI02200
F1	slave cylinder 1	
K2	master cylinder 2	pair of cylinders complete 035UNI02200
F2	slave cylinder 2	

**3.7 Hydraulic diagram (with wheel free lift)**

UNI-LIFT NT Plus  
99 550 00 00 5  
SN: 158936

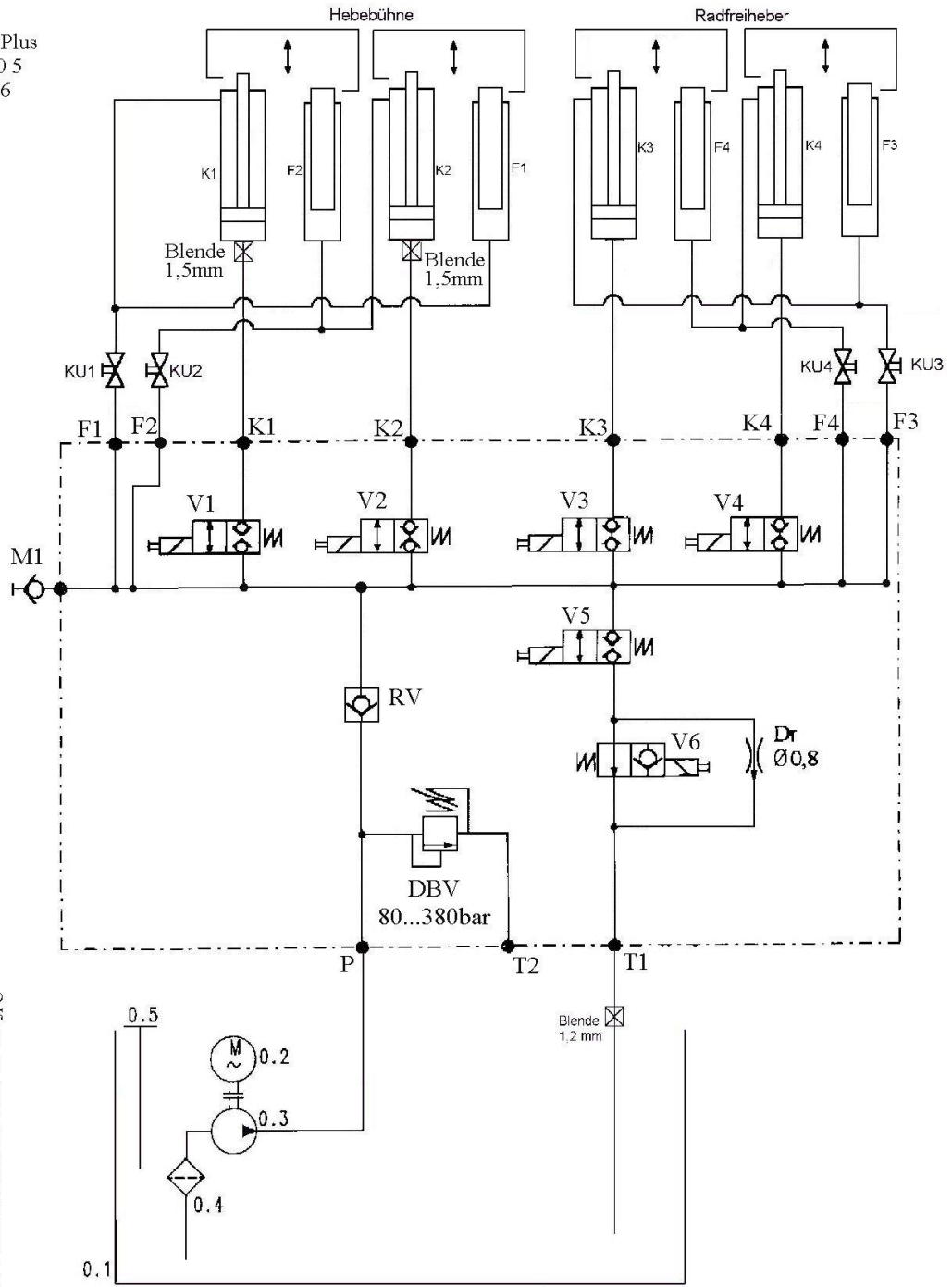

H-Plan UNI.LIFT NT Plus 05-09 .jpg

## Hydraulic parts list

Nr.	description	order number
0.6	oil tank	
0.7	sub oil motor	992856
0.8	gear pump	980340
0.9	oil filter	980012
0.10	oil level gauge	980098
RV	holding valve	980480
DBV	pressure control valve	155211
V1	double seat valve (manual unlocking)	600001
V2	double seat valve (manual unlocking)	600001
V3	double seat valve (manual unlocking)	600001
V4	double seat valve (manual unlocking)	600001
V5	double seat valve (manual unlocking)	600001
V6	double seat valve (manual unlocking)	159318
DR	regulating valve Ø 0,8	
M1	measuring connection	155470
KU1	ball valve	980513
KU2	ball valve	980513
KU3	ball valve	980513
KU4	ball valve	980513
K1	master cylinder 1	pair of cylinders complete 035UNI02200
F1	slave cylinder 1	
K2	master cylinder 2	pair of cylinders complete 035UNI02200
F2	slave cylinder 2	
K3	master cylinder wheel free lift	
K4	master cylinder wheel free lift	
F3	slave cylinder wheel free lift	
F4	slave cylinder wheel free lift	

**3.8 Hydraulic diagram (with wheel free lift and play detector)**

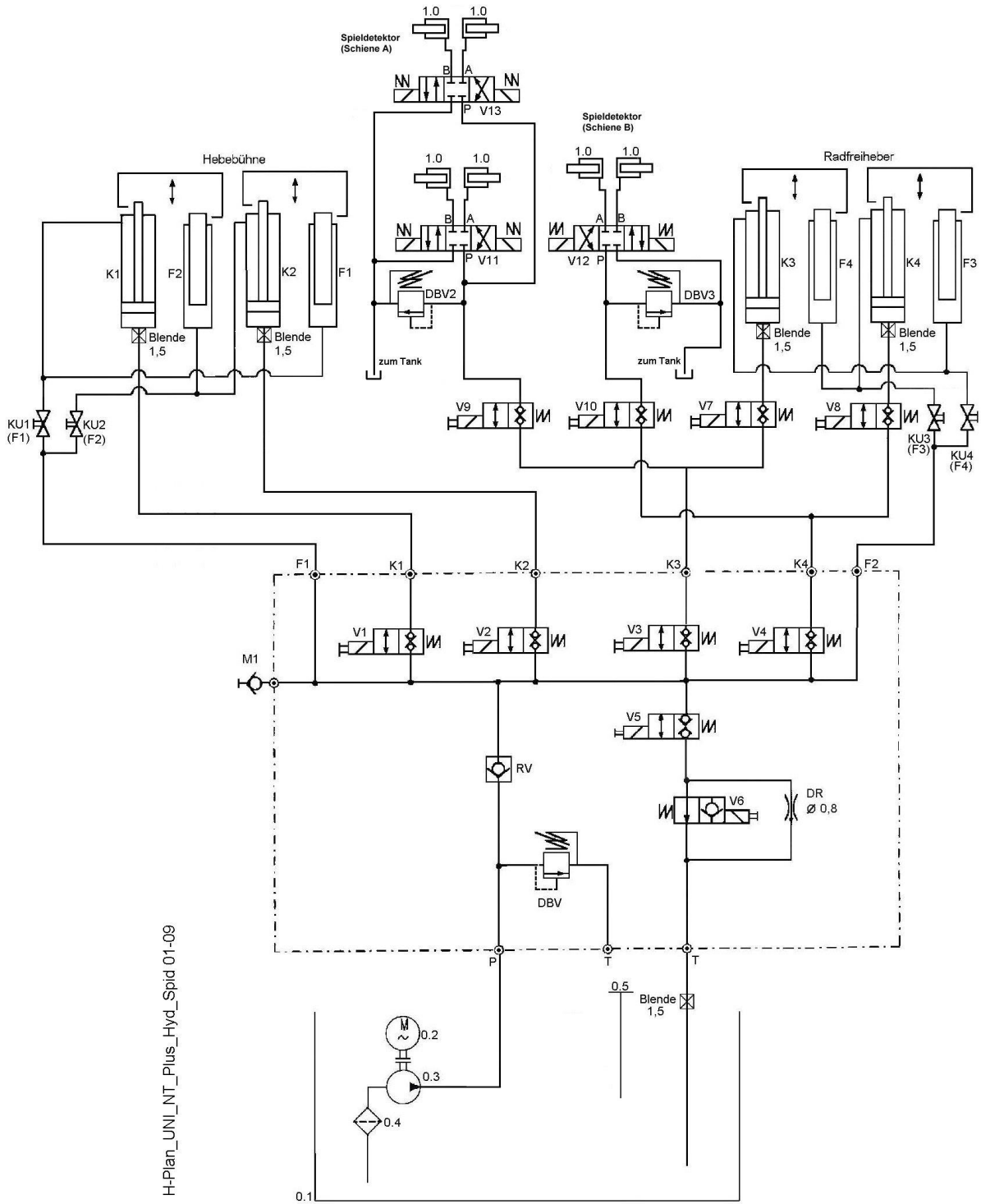

H-Plan\_UNI\_NT\_Plus\_Hyd\_Spid 01-09

## Hydraulic parts list

Nr.	description	order number
0.11	oil tank	
0.12	sub oil motor	992856
0.13	gear pump	980340
0.14	oil filter	980012
0.15	oil level gauge	980098
RV	holding valve	980480
DBV	pressure control valve	155211
V1	double seat valve (manual unlocking)	600001
V2	double seat valve (manual unlocking)	600001
V3	double seat valve (manual unlocking)	600001
V4	double seat valve (manual unlocking)	600001
V5	double seat valve (manual unlocking)	600001
V6	double seat valve (manual unlocking)	159318
V7	double seat valve (manual unlocking)	980853
V8	double seat valve (manual unlocking)	980853
DR	regulating valve Ø 0,8	
M1	measuring connection	155470
KU1	ball valve	980513
KU2	ball valve	980513
KU3	ball valve	980513
KU4	ball valve	980513
K1	master cylinder 1	pair of cylinders complete 035UNI02200
F1	slave cylinder 1	
K2	master cylinder 2	pair of cylinders complete 035UNI02200
F2	slave cylinder 2	
K3	master cylinder wheel free lift	
K4	master cylinder wheel free lift	
F3	slave cylinder wheel free lift	
F4	slave cylinder wheel free lift	

3.9 Electrical diagram drawing (without wheel free lift)

0	1	2	3	4	5	6	7	8	9
---	---	---	---	---	---	---	---	---	---

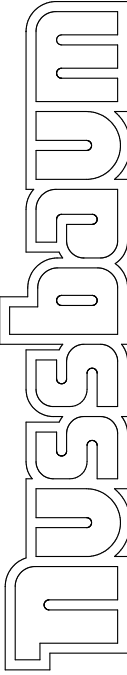

## SCHALTPLAN

**Nussbaum Hebetchnik**  
GmbH & Co. KG  
Korker Straße 24  
D-77694 Kehl-Bodersweier  
Tel.: +49(0)7853/899-0

OBJEKT : Unilift NT  
ANLAGE :  
KUNDE :  
SCHALTPLANNR: Unilift NT 11/12/001

**Erdung nach örtlichen Vorschriften**  
Vor Inbetriebnahme prüfen, ob Motornennstrom mit Motorschutzrelais übereinstimmt. Alle Klemmstellen auf Ordnungsgemäße Verbindung und alle Kontaktschrauben auf festen Sitz prüfen.  
Vor Inbetriebnahme Verdrahtung und Steuerung auf richtige Funktion überprüfen. Keine Inbetriebnahme von unbefugter Seite vornehmen lassen. Änderungen vorbehalten

**3.) Sicherheitsprüfung und Schutzmaßnahmen**  
Der Schaltplan wurde unter Beachtung der anerkannten Regeln der Technik nach VDE0100/013 sowie der Unfallverhütungsvorschrift VBG4(elektrische Anlagen und Betriebsmittel) gefertigt bzw. gezeichnet und geprüft.  
1. Spannungsprüfung und/oder Isolationsprüfung des Schaltplanes nach VDE0100/5.73.  
2. Prüfung der Wirkbarkeit der angewandten Schutzmaßnahmen bei indirektem Berühren.  
3. Funktionsprüfung und Stückprüfung nach VDE0100/11.87.  
An Schutzmaßnahmen wurden getroffen:  
1. Schutz nach VDE0100/5.73, Par. 4.  
2. Schutz bei indirektem Berühren nach VDE0100/5.73, Par. 5.

**1.) Schaltpläne und Schaltunterlagen**  
Die Schaltpläne sind von uns nach bestem Geissen angefertigt. Für bestellte Schaltpläne und Schaltunterlagen wird von uns keine Gewähr für die Richtigkeit dieser Unterlagen übernommen. Dies trifft insbesondere für Schaltungen zu, die von uns nach fremden Plänen angefertigt werden. Diese werden von uns nur nach den vom Auftragnehmer überlassenen Unterlagen des Herstellers ausgeführt.

**2.) Funktionsprüfung der Schaltanlagen**  
Schaltpläne sind keine Serienzeugnisse. Bei der Prüfung der Schaltkreise im Werk können Fehlgänge wie Fehler, Thermäste und Motoren nicht einbezogen werden. Auch bei sorgfältiger Prüfung lassen sich deshalb Funktions- und Schaltungsfehler nicht immer vermeiden. Im Rahmen unserer Gewährleistung bei der Inbetriebnahme beseitigt, unsere Haftung. Bei Inbetriebnahme ohne Hinzuziehung unseres Service wird deshalb keine Mängel-Haftung übernommen. Die Inbetriebnahme erfolgt auf dem besten Wissen und Gewissen. Die Kosten für die notwendigen gemeinsamen Schaltanlagen werden deshalb nur gegen Berechnung gemäß unseren Service-Bedingungen ausgeführt. Kosten für Nachbesserungen durch Dritte können wir nicht anerkennen.

Diese Pläne sind auf einem CAD-System erstellt worden  
Um die Pläne immer auf dem aktuellen Stand zu halten, bitten wir  
Änderungen nur durch uns vornehmen zu lassen.

Datum	=	Unilift NT	=	
Bearb. BOE	+			
Bearr. 20.03.17				

<table border="1" style="width: 100%; border-collapse: collapse;"> <tr> <td style="width: 50%; text-align: center;">Nussbaum Hebetchnik GmbH &amp; Co. KG Korker Straße 24 D-77694 Kehl - Bodersweier Tel.: +49(0)7853/899-0 Fax: +49(0)7853/897</td> <td style="width: 50%; text-align: center;">Unilift NT</td> </tr> </table>	Nussbaum Hebetchnik GmbH & Co. KG Korker Straße 24 D-77694 Kehl - Bodersweier Tel.: +49(0)7853/899-0 Fax: +49(0)7853/897	Unilift NT	Deckblatt
Nussbaum Hebetchnik GmbH & Co. KG Korker Straße 24 D-77694 Kehl - Bodersweier Tel.: +49(0)7853/899-0 Fax: +49(0)7853/897	Unilift NT		
Ers. f.	Ers. d.		
Ursprr.	B.I. 7 Bl.		

2





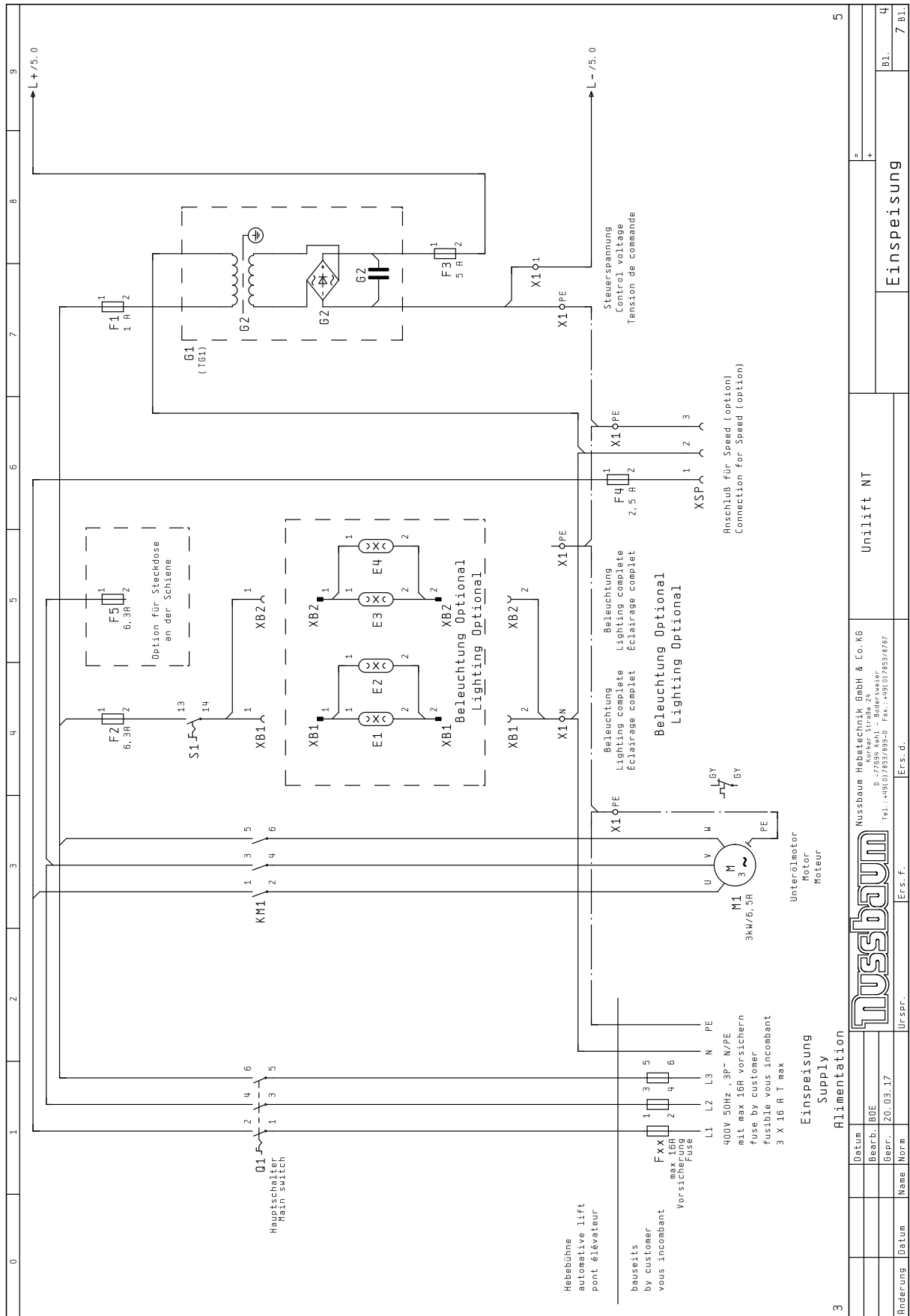

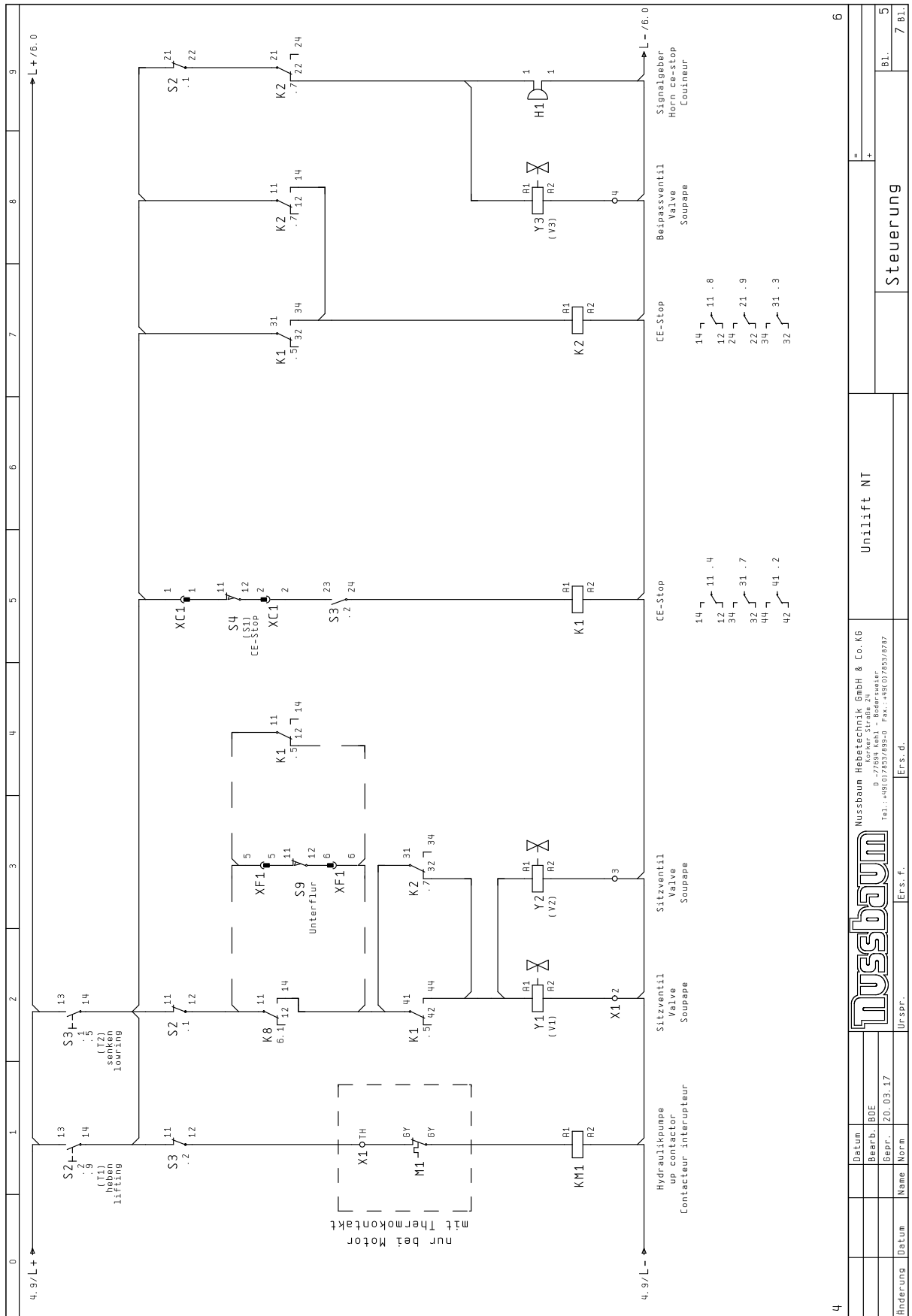

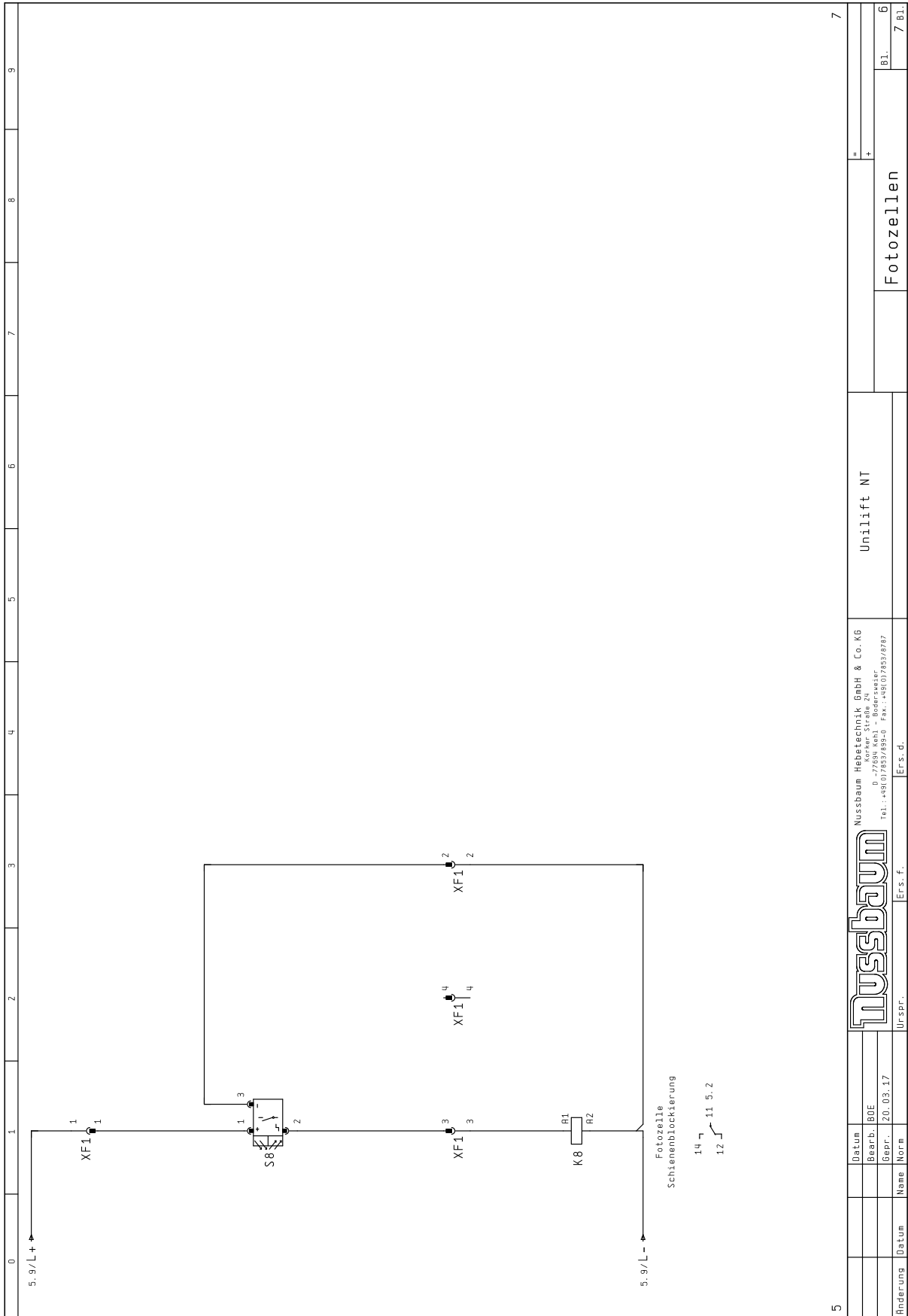

5		7	
-		+	
+		-	
Fotozellen		Fotozellen	
UniLift NT		UniLift NT	
Nussbaum Hebetchnik GmbH & Co. KG D-77694 Kehl - Bodensee Tel.: +49 (0)7853/898-0 Fax: +49 (0)7853/897		Nussbaum Hebetchnik GmbH & Co. KG D-77694 Kehl - Bodensee Tel.: +49 (0)7853/898-0 Fax: +49 (0)7853/897	
Urspr.		Ers. f.	
Ers. d.		Ers. d.	
Datum	Bearb.	BDE	
Gepr.	20.03.17		
Name	Norm		
Datum			
6		7 Bl.	













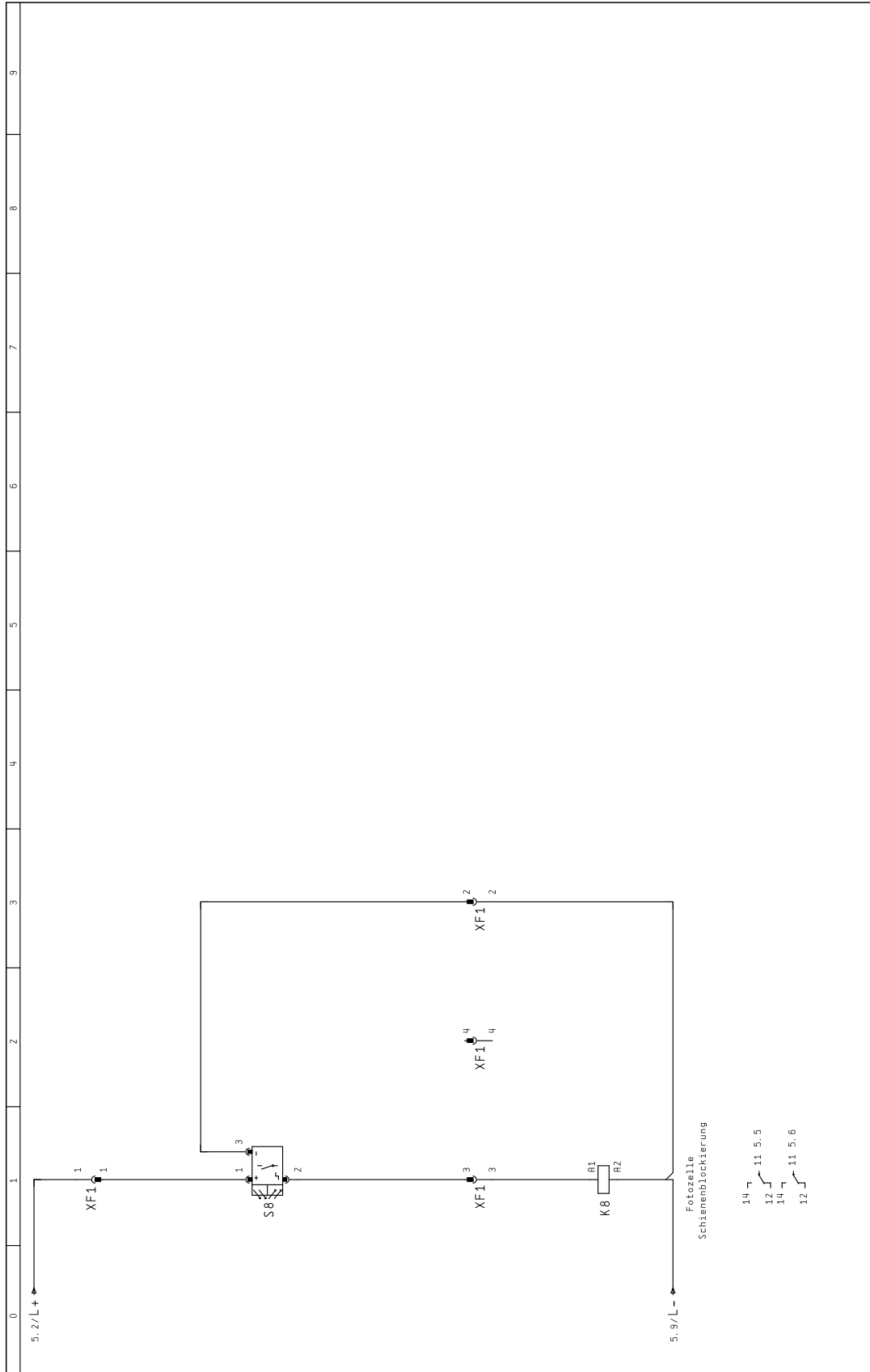

5	7	Fotozellen		Bl.	6
Unilift NT Plus 2011 V001		Ers.f.		7 Bl.	
Nussbaum Hebeltechnik GmbH & Co. KG D-77894 Wehl - Badersweiler Tel.: +49(0)7833/89-0 Fax: +49(0)7833/897		Ers.f.			
Datum	16.08.11	Ers.f.			
Bearb.	BOE	Ers.f.			
Gepr.	ZD.03.17	Ers.f.			
Anderung	Datum	Name	Norm		



**3.11 Electrical diagram SPID**

0	1	2	3	4	5	6	7	8	9
---	---	---	---	---	---	---	---	---	---

**Nussbaum Hebetchnik**  
GmbH & Co. KG  
Korker Straße 24  
D-77694 Kehl Bodersweier  
Tel.: +49(0)7853/899-0

# SCHALTPLAN

**Objekt** : SPID FUNK Canbox  
**Anlage** : : :  
**Kunde** : : :  
**Schaltplannr:** SPID FUNK Canbox 03/17/001

**3.) Sicherheitsprüfung und Schutzmaßnahmen**  
Der Schaltschrank wurde unter Beachtung der anerkannten Regeln der Technik nach VDE0100/5:73 sowie der Unfallverhütungsvorschrift VGB/elektrische Anlagen und folgende Prüfungen wurden durchgeführt:  
1. Spannungsprüfung und/oder Isolationsprüfung des Schaltschranks nach VDE0100/5:73.  
2. Funktionsprüfung und/oder Schutzmaßnahme bei indirektem Berühren nach VDE0100/7:75 Par. 2/er angewandten Schutzmaßnahme bei indirektem Berühren.  
3. Funktionsprüfung und/oder Schutzprüfung nach VDE560/11:87.  
4. Schutz gegen direktes Berühren nach VDE0100/5:73: Par. 4.  
5. Schutz bei indirektem Berühren nach VDE0100/5:73: Par. 5.

**1.) Schaltpläne und Schaltunterlagen**  
Die Schaltpläne werden von uns nach bestem Gewissen angefertigt. Für bestellte Schaltpläne und Schaltunterlagen wird von uns keine Gewähr für die Richtigkeit dieser Unterlagen übernommen. Dies wird von uns nur nach dem vom Auftraggeber überlassenen Unterlagen des Herstellers ausgeführt.

**2.) Funktionsprüfung der Schaltanlagen**  
Schaltpläne sind keine Serienerzeugnisse. Bei der Prüfung des Schaltschranks im Werk können Fehler wie fehlerhafte Bauteile und Motoren nicht entzogen werden. Auch bei vorfertigter oder hat durch uns zu erfolgen. Sie ist grundsätzlich Bestandteil unseres Auftrages. Mängel werden im Rahmen unserer Gewährleistung bei Gesamtabnahme festgestellt. Keine Mängel-Haftung übernommen. Nachbesserungen einschließlich der Berechtigung von Schaltplänen bei nicht von uns in Betrieb ausgearbeiteten Schaltungen werden durch Bestätigung der Bestätigungsgemäße unserer Bestätigung ausgenommen. Kosten für Nachbesserungen durch Dritte können auf nicht anerkennen.

Diese Pläne sind auf einem CAD-System erstellt worden  
Um die Pläne immer auf dem aktuellen Stand zu halten, bitten wir  
Änderungen nur durch uns vornehmen zu lassen.

**Erdung nach örtlichen Vorschriften**  
Vor Inbetriebnahme prüfen, ob Motornennstrom mit Motorschutzrelais übereinstimmt. Alle Klemmstellen auf Ordnungsgemäße Verbindung und alle Kontaktschrauben auf festen Sitz prüfen.  
Vor Inbetriebnahme Verdrahtung und Steuerung auf richtige Funktion überprüfen. Keine Inbetriebnahme von unbefugter Seite vornehmen lassen. Änderungen vorbehalten

**1.)** Datum: \_\_\_\_\_  
Bearb.: BOE  
Bepr.: 20.03.17

**2.)** Datum: \_\_\_\_\_  
Bepr.: \_\_\_\_\_

**3.)** Datum: \_\_\_\_\_  
Bepr.: \_\_\_\_\_

**4.)** Datum: \_\_\_\_\_  
Bepr.: \_\_\_\_\_

**5.)** Datum: \_\_\_\_\_  
Bepr.: \_\_\_\_\_

**6.)** Datum: \_\_\_\_\_  
Bepr.: \_\_\_\_\_

**7.)** Datum: \_\_\_\_\_  
Bepr.: \_\_\_\_\_

**8.)** Datum: \_\_\_\_\_  
Bepr.: \_\_\_\_\_

**9.)** Datum: \_\_\_\_\_  
Bepr.: \_\_\_\_\_

**10.)** Datum: \_\_\_\_\_  
Bepr.: \_\_\_\_\_

**11.)** Datum: \_\_\_\_\_  
Bepr.: \_\_\_\_\_

**12.)** Datum: \_\_\_\_\_  
Bepr.: \_\_\_\_\_

**13.)** Datum: \_\_\_\_\_  
Bepr.: \_\_\_\_\_

**14.)** Datum: \_\_\_\_\_  
Bepr.: \_\_\_\_\_

**15.)** Datum: \_\_\_\_\_  
Bepr.: \_\_\_\_\_

**16.)** Datum: \_\_\_\_\_  
Bepr.: \_\_\_\_\_

**17.)** Datum: \_\_\_\_\_  
Bepr.: \_\_\_\_\_

**18.)** Datum: \_\_\_\_\_  
Bepr.: \_\_\_\_\_

**19.)** Datum: \_\_\_\_\_  
Bepr.: \_\_\_\_\_

**20.)** Datum: \_\_\_\_\_  
Bepr.: \_\_\_\_\_

**21.)** Datum: \_\_\_\_\_  
Bepr.: \_\_\_\_\_

**22.)** Datum: \_\_\_\_\_  
Bepr.: \_\_\_\_\_

**23.)** Datum: \_\_\_\_\_  
Bepr.: \_\_\_\_\_

**24.)** Datum: \_\_\_\_\_  
Bepr.: \_\_\_\_\_

**25.)** Datum: \_\_\_\_\_  
Bepr.: \_\_\_\_\_

**26.)** Datum: \_\_\_\_\_  
Bepr.: \_\_\_\_\_

**27.)** Datum: \_\_\_\_\_  
Bepr.: \_\_\_\_\_

**28.)** Datum: \_\_\_\_\_  
Bepr.: \_\_\_\_\_

**29.)** Datum: \_\_\_\_\_  
Bepr.: \_\_\_\_\_

**30.)** Datum: \_\_\_\_\_  
Bepr.: \_\_\_\_\_

**31.)** Datum: \_\_\_\_\_  
Bepr.: \_\_\_\_\_

**32.)** Datum: \_\_\_\_\_  
Bepr.: \_\_\_\_\_

**33.)** Datum: \_\_\_\_\_  
Bepr.: \_\_\_\_\_

**34.)** Datum: \_\_\_\_\_  
Bepr.: \_\_\_\_\_

**35.)** Datum: \_\_\_\_\_  
Bepr.: \_\_\_\_\_

**36.)** Datum: \_\_\_\_\_  
Bepr.: \_\_\_\_\_

**37.)** Datum: \_\_\_\_\_  
Bepr.: \_\_\_\_\_

**38.)** Datum: \_\_\_\_\_  
Bepr.: \_\_\_\_\_

**39.)** Datum: \_\_\_\_\_  
Bepr.: \_\_\_\_\_

**40.)** Datum: \_\_\_\_\_  
Bepr.: \_\_\_\_\_

**41.)** Datum: \_\_\_\_\_  
Bepr.: \_\_\_\_\_

**42.)** Datum: \_\_\_\_\_  
Bepr.: \_\_\_\_\_

**43.)** Datum: \_\_\_\_\_  
Bepr.: \_\_\_\_\_

**44.)** Datum: \_\_\_\_\_  
Bepr.: \_\_\_\_\_

**45.)** Datum: \_\_\_\_\_  
Bepr.: \_\_\_\_\_

**46.)** Datum: \_\_\_\_\_  
Bepr.: \_\_\_\_\_

**47.)** Datum: \_\_\_\_\_  
Bepr.: \_\_\_\_\_

**48.)** Datum: \_\_\_\_\_  
Bepr.: \_\_\_\_\_

**49.)** Datum: \_\_\_\_\_  
Bepr.: \_\_\_\_\_

**50.)** Datum: \_\_\_\_\_  
Bepr.: \_\_\_\_\_

**51.)** Datum: \_\_\_\_\_  
Bepr.: \_\_\_\_\_

**52.)** Datum: \_\_\_\_\_  
Bepr.: \_\_\_\_\_

**53.)** Datum: \_\_\_\_\_  
Bepr.: \_\_\_\_\_

**54.)** Datum: \_\_\_\_\_  
Bepr.: \_\_\_\_\_

**55.)** Datum: \_\_\_\_\_  
Bepr.: \_\_\_\_\_

**56.)** Datum: \_\_\_\_\_  
Bepr.: \_\_\_\_\_

**57.)** Datum: \_\_\_\_\_  
Bepr.: \_\_\_\_\_

**58.)** Datum: \_\_\_\_\_  
Bepr.: \_\_\_\_\_

**59.)** Datum: \_\_\_\_\_  
Bepr.: \_\_\_\_\_

**60.)** Datum: \_\_\_\_\_  
Bepr.: \_\_\_\_\_

**61.)** Datum: \_\_\_\_\_  
Bepr.: \_\_\_\_\_

**62.)** Datum: \_\_\_\_\_  
Bepr.: \_\_\_\_\_

**63.)** Datum: \_\_\_\_\_  
Bepr.: \_\_\_\_\_

**64.)** Datum: \_\_\_\_\_  
Bepr.: \_\_\_\_\_

**65.)** Datum: \_\_\_\_\_  
Bepr.: \_\_\_\_\_

**66.)** Datum: \_\_\_\_\_  
Bepr.: \_\_\_\_\_

**67.)** Datum: \_\_\_\_\_  
Bepr.: \_\_\_\_\_

**68.)** Datum: \_\_\_\_\_  
Bepr.: \_\_\_\_\_

**69.)** Datum: \_\_\_\_\_  
Bepr.: \_\_\_\_\_

**70.)** Datum: \_\_\_\_\_  
Bepr.: \_\_\_\_\_

**71.)** Datum: \_\_\_\_\_  
Bepr.: \_\_\_\_\_

**72.)** Datum: \_\_\_\_\_  
Bepr.: \_\_\_\_\_

**73.)** Datum: \_\_\_\_\_  
Bepr.: \_\_\_\_\_

**74.)** Datum: \_\_\_\_\_  
Bepr.: \_\_\_\_\_

**75.)** Datum: \_\_\_\_\_  
Bepr.: \_\_\_\_\_

**76.)** Datum: \_\_\_\_\_  
Bepr.: \_\_\_\_\_

**77.)** Datum: \_\_\_\_\_  
Bepr.: \_\_\_\_\_

**78.)** Datum: \_\_\_\_\_  
Bepr.: \_\_\_\_\_

**79.)** Datum: \_\_\_\_\_  
Bepr.: \_\_\_\_\_

**80.)** Datum: \_\_\_\_\_  
Bepr.: \_\_\_\_\_

**81.)** Datum: \_\_\_\_\_  
Bepr.: \_\_\_\_\_

**82.)** Datum: \_\_\_\_\_  
Bepr.: \_\_\_\_\_

**83.)** Datum: \_\_\_\_\_  
Bepr.: \_\_\_\_\_

**84.)** Datum: \_\_\_\_\_  
Bepr.: \_\_\_\_\_

**85.)** Datum: \_\_\_\_\_  
Bepr.: \_\_\_\_\_

**86.)** Datum: \_\_\_\_\_  
Bepr.: \_\_\_\_\_

**87.)** Datum: \_\_\_\_\_  
Bepr.: \_\_\_\_\_

**88.)** Datum: \_\_\_\_\_  
Bepr.: \_\_\_\_\_

**89.)** Datum: \_\_\_\_\_  
Bepr.: \_\_\_\_\_

**90.)** Datum: \_\_\_\_\_  
Bepr.: \_\_\_\_\_

**91.)** Datum: \_\_\_\_\_  
Bepr.: \_\_\_\_\_

**92.)** Datum: \_\_\_\_\_  
Bepr.: \_\_\_\_\_

**93.)** Datum: \_\_\_\_\_  
Bepr.: \_\_\_\_\_

**94.)** Datum: \_\_\_\_\_  
Bepr.: \_\_\_\_\_

**95.)** Datum: \_\_\_\_\_  
Bepr.: \_\_\_\_\_

**96.)** Datum: \_\_\_\_\_  
Bepr.: \_\_\_\_\_

**97.)** Datum: \_\_\_\_\_  
Bepr.: \_\_\_\_\_

**98.)** Datum: \_\_\_\_\_  
Bepr.: \_\_\_\_\_

**99.)** Datum: \_\_\_\_\_  
Bepr.: \_\_\_\_\_

**100.)** Datum: \_\_\_\_\_  
Bepr.: \_\_\_\_\_

**101.)** Datum: \_\_\_\_\_  
Bepr.: \_\_\_\_\_

**102.)** Datum: \_\_\_\_\_  
Bepr.: \_\_\_\_\_

**103.)** Datum: \_\_\_\_\_  
Bepr.: \_\_\_\_\_

**104.)** Datum: \_\_\_\_\_  
Bepr.: \_\_\_\_\_

**105.)** Datum: \_\_\_\_\_  
Bepr.: \_\_\_\_\_

**106.)** Datum: \_\_\_\_\_  
Bepr.: \_\_\_\_\_

**107.)** Datum: \_\_\_\_\_  
Bepr.: \_\_\_\_\_

**108.)** Datum: \_\_\_\_\_  
Bepr.: \_\_\_\_\_

**109.)** Datum: \_\_\_\_\_  
Bepr.: \_\_\_\_\_

**110.)** Datum: \_\_\_\_\_  
Bepr.: \_\_\_\_\_

**111.)** Datum: \_\_\_\_\_  
Bepr.: \_\_\_\_\_

**112.)** Datum: \_\_\_\_\_  
Bepr.: \_\_\_\_\_

**113.)** Datum: \_\_\_\_\_  
Bepr.: \_\_\_\_\_

**114.)** Datum: \_\_\_\_\_  
Bepr.: \_\_\_\_\_

**115.)** Datum: \_\_\_\_\_  
Bepr.: \_\_\_\_\_

**116.)** Datum: \_\_\_\_\_  
Bepr.: \_\_\_\_\_

**117.)** Datum: \_\_\_\_\_  
Bepr.: \_\_\_\_\_

**118.)** Datum: \_\_\_\_\_  
Bepr.: \_\_\_\_\_

**119.)** Datum: \_\_\_\_\_  
Bepr.: \_\_\_\_\_

**120.)** Datum: \_\_\_\_\_  
Bepr.: \_\_\_\_\_

**121.)** Datum: \_\_\_\_\_  
Bepr.: \_\_\_\_\_

**122.)** Datum: \_\_\_\_\_  
Bepr.: \_\_\_\_\_

**123.)** Datum: \_\_\_\_\_  
Bepr.: \_\_\_\_\_

**124.)** Datum: \_\_\_\_\_  
Bepr.: \_\_\_\_\_

**125.)** Datum: \_\_\_\_\_  
Bepr.: \_\_\_\_\_

**126.)** Datum: \_\_\_\_\_  
Bepr.: \_\_\_\_\_

**127.)** Datum: \_\_\_\_\_  
Bepr.: \_\_\_\_\_

**128.)** Datum: \_\_\_\_\_  
Bepr.: \_\_\_\_\_

**129.)** Datum: \_\_\_\_\_  
Bepr.: \_\_\_\_\_

**130.)** Datum: \_\_\_\_\_  
Bepr.: \_\_\_\_\_

**131.)** Datum: \_\_\_\_\_  
Bepr.: \_\_\_\_\_

**132.)** Datum: \_\_\_\_\_  
Bepr.: \_\_\_\_\_

**133.)** Datum: \_\_\_\_\_  
Bepr.: \_\_\_\_\_

**134.)** Datum: \_\_\_\_\_  
Bepr.: \_\_\_\_\_

**135.)** Datum: \_\_\_\_\_  
Bepr.: \_\_\_\_\_

**136.)** Datum: \_\_\_\_\_  
Bepr.: \_\_\_\_\_

**137.)** Datum: \_\_\_\_\_  
Bepr.: \_\_\_\_\_

**138.)** Datum: \_\_\_\_\_  
Bepr.: \_\_\_\_\_

**139.)** Datum: \_\_\_\_\_  
Bepr.: \_\_\_\_\_

**140.)** Datum: \_\_\_\_\_  
Bepr.: \_\_\_\_\_

**141.)** Datum: \_\_\_\_\_  
Bepr.: \_\_\_\_\_

**142.)** Datum: \_\_\_\_\_  
Bepr.: \_\_\_\_\_

**143.)** Datum: \_\_\_\_\_  
Bepr.: \_\_\_\_\_

**144.)** Datum: \_\_\_\_\_  
Bepr.: \_\_\_\_\_

**145.)** Datum: \_\_\_\_\_  
Bepr.: \_\_\_\_\_

**146.)** Datum: \_\_\_\_\_  
Bepr.: \_\_\_\_\_

**147.)** Datum: \_\_\_\_\_  
Bepr.: \_\_\_\_\_

**148.)** Datum: \_\_\_\_\_  
Bepr.: \_\_\_\_\_

**149.)** Datum: \_\_\_\_\_  
Bepr.: \_\_\_\_\_

**150.)** Datum: \_\_\_\_\_  
Bepr.: \_\_\_\_\_

**151.)** Datum: \_\_\_\_\_  
Bepr.: \_\_\_\_\_

**152.)** Datum: \_\_\_\_\_  
Bepr.: \_\_\_\_\_

**153.)** Datum: \_\_\_\_\_  
Bepr.: \_\_\_\_\_

**154.)** Datum: \_\_\_\_\_  
Bepr.: \_\_\_\_\_

**155.)** Datum: \_\_\_\_\_  
Bepr.: \_\_\_\_\_

**156.)** Datum: \_\_\_\_\_  
Bepr.: \_\_\_\_\_

**157.)** Datum: \_\_\_\_\_  
Bepr.: \_\_\_\_\_

**158.)** Datum: \_\_\_\_\_  
Bepr.: \_\_\_\_\_

**159.)** Datum: \_\_\_\_\_  
Bepr.: \_\_\_\_\_

**160.)** Datum: \_\_\_\_\_  
Bepr.: \_\_\_\_\_

**161.)** Datum: \_\_\_\_\_  
Bepr.: \_\_\_\_\_

**162.)** Datum: \_\_\_\_\_  
Bepr.: \_\_\_\_\_

**163.)** Datum: \_\_\_\_\_  
Bepr.: \_\_\_\_\_

**164.)** Datum: \_\_\_\_\_  
Bepr.: \_\_\_\_\_

**165.)** Datum: \_\_\_\_\_  
Bepr.: \_\_\_\_\_

**166.)** Datum: \_\_\_\_\_  
Bepr.: \_\_\_\_\_

**167.)** Datum: \_\_\_\_\_  
Bepr.: \_\_\_\_\_

**168.)** Datum: \_\_\_\_\_  
Bepr.: \_\_\_\_\_

**169.)** Datum: \_\_\_\_\_  
Bepr.: \_\_\_\_\_

**170.)** Datum: \_\_\_\_\_  
Bepr.: \_\_\_\_\_

**171.)** Datum: \_\_\_\_\_  
Bepr.: \_\_\_\_\_

**172.)** Datum: \_\_\_\_\_  
Bepr.: \_\_\_\_\_

**173.)** Datum: \_\_\_\_\_  
Bepr.: \_\_\_\_\_

**174.)** Datum: \_\_\_\_\_  
Bepr.: \_\_\_\_\_

**175.)** Datum: \_\_\_\_\_  
Bepr.: \_\_\_\_\_

**176.)** Datum: \_\_\_\_\_  
Bepr.: \_\_\_\_\_

**177.)** Datum: \_\_\_\_\_  
Bepr.: \_\_\_\_\_

**178.)** Datum: \_\_\_\_\_  
Bepr.: \_\_\_\_\_

**179.)** Datum: \_\_\_\_\_  
Bepr.: \_\_\_\_\_

**180.)** Datum: \_\_\_\_\_  
Bepr.: \_\_\_\_\_

**181.)** Datum: \_\_\_\_\_  
Bepr.: \_\_\_\_\_

**182.)** Datum: \_\_\_\_\_  
Bepr.: \_\_\_\_\_

**183.)** Datum: \_\_\_\_\_  
Bepr.: \_\_\_\_\_

**184.)** Datum: \_\_\_\_\_  
Bepr.: \_\_\_\_\_

**185.)** Datum: \_\_\_\_\_  
Bepr.: \_\_\_\_\_

**186.)** Datum: \_\_\_\_\_  
Bepr.: \_\_\_\_\_

**187.)** Datum: \_\_\_\_\_  
Bepr.: \_\_\_\_\_

**188.)** Datum: \_\_\_\_\_  
Bepr.: \_\_\_\_\_

**189.)** Datum: \_\_\_\_\_  
Bepr.: \_\_\_\_\_

**190.)** Datum: \_\_\_\_\_  
Bepr.: \_\_\_\_\_

**191.)** Datum: \_\_\_\_\_  
Bepr.: \_\_\_\_\_

**192.)** Datum: \_\_\_\_\_  
Bepr.: \_\_\_\_\_

**193.)** Datum: \_\_\_\_\_  
Bepr.: \_\_\_\_\_

**194.)** Datum: \_\_\_\_\_  
Bepr.: \_\_\_\_\_

**195.)** Datum: \_\_\_\_\_  
Bepr.: \_\_\_\_\_

**196.)** Datum: \_\_\_\_\_  
Bepr.: \_\_\_\_\_

**197.)** Datum: \_\_\_\_\_  
Bepr.: \_\_\_\_\_

**198.)** Datum: \_\_\_\_\_  
Bepr.: \_\_\_\_\_

**199.)** Datum: \_\_\_\_\_  
Bepr.: \_\_\_\_\_

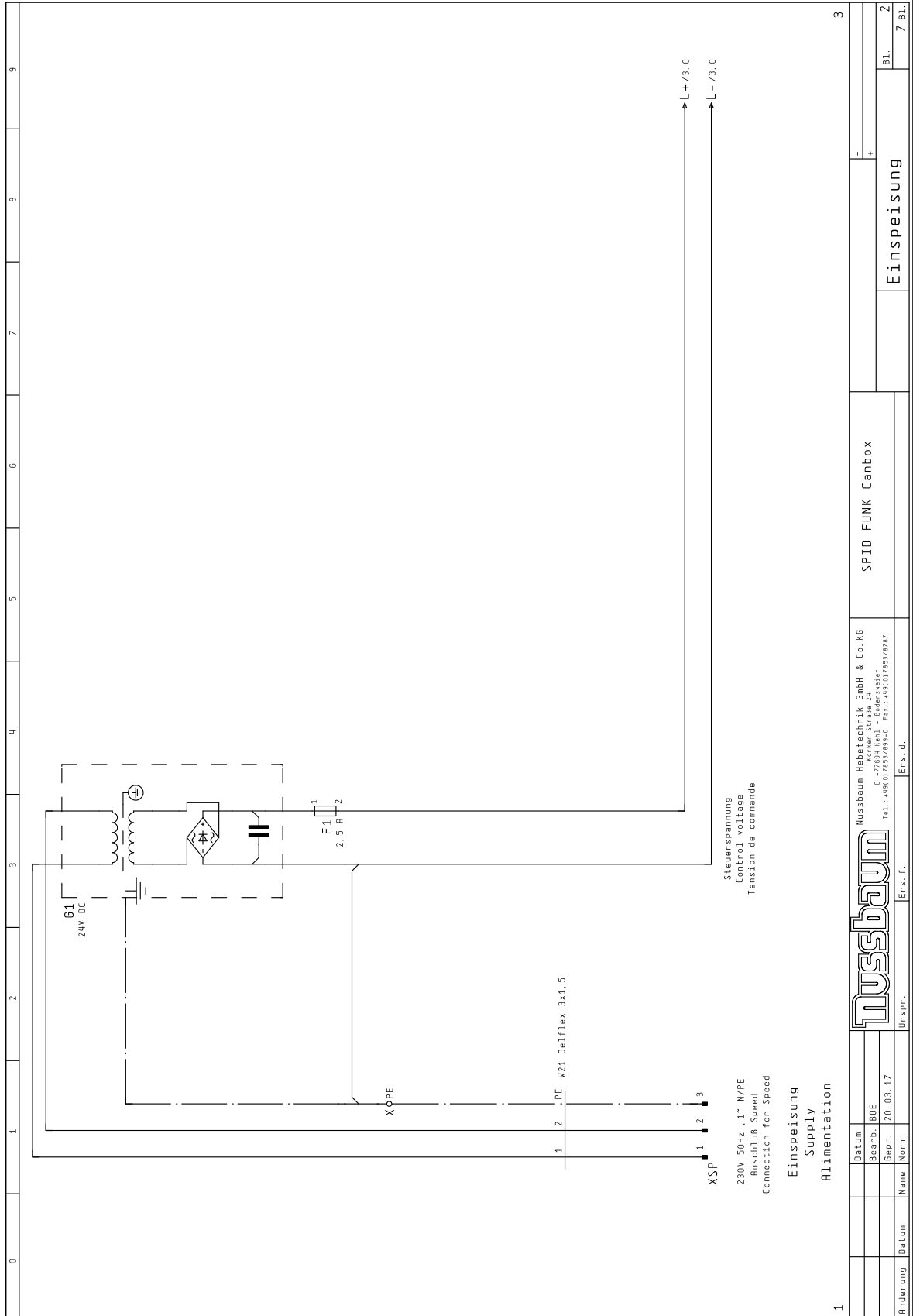

1		3	
Einspeisung		Einspeisung	
Supply Alimentation		SPID FUNK Canbox	
Nussbaum Hebe-technik GmbH & Co. KG		Nussbaum Hebe-technik GmbH & Co. KG	
0 - 77684 Kehl - Biedersteiner		0 - 77684 Kehl - Biedersteiner	
Tel.: +49(0)7853/889-0 Fax: +49(0)7853/887		Tel.: +49(0)7853/889-0 Fax: +49(0)7853/887	
Ers. f.		Ers. d.	
Ur-spr.		Ers. f.	
Datum	Bearb.	BOE	
Gepr.	20.03.17		
Name	Norm		
Datum			

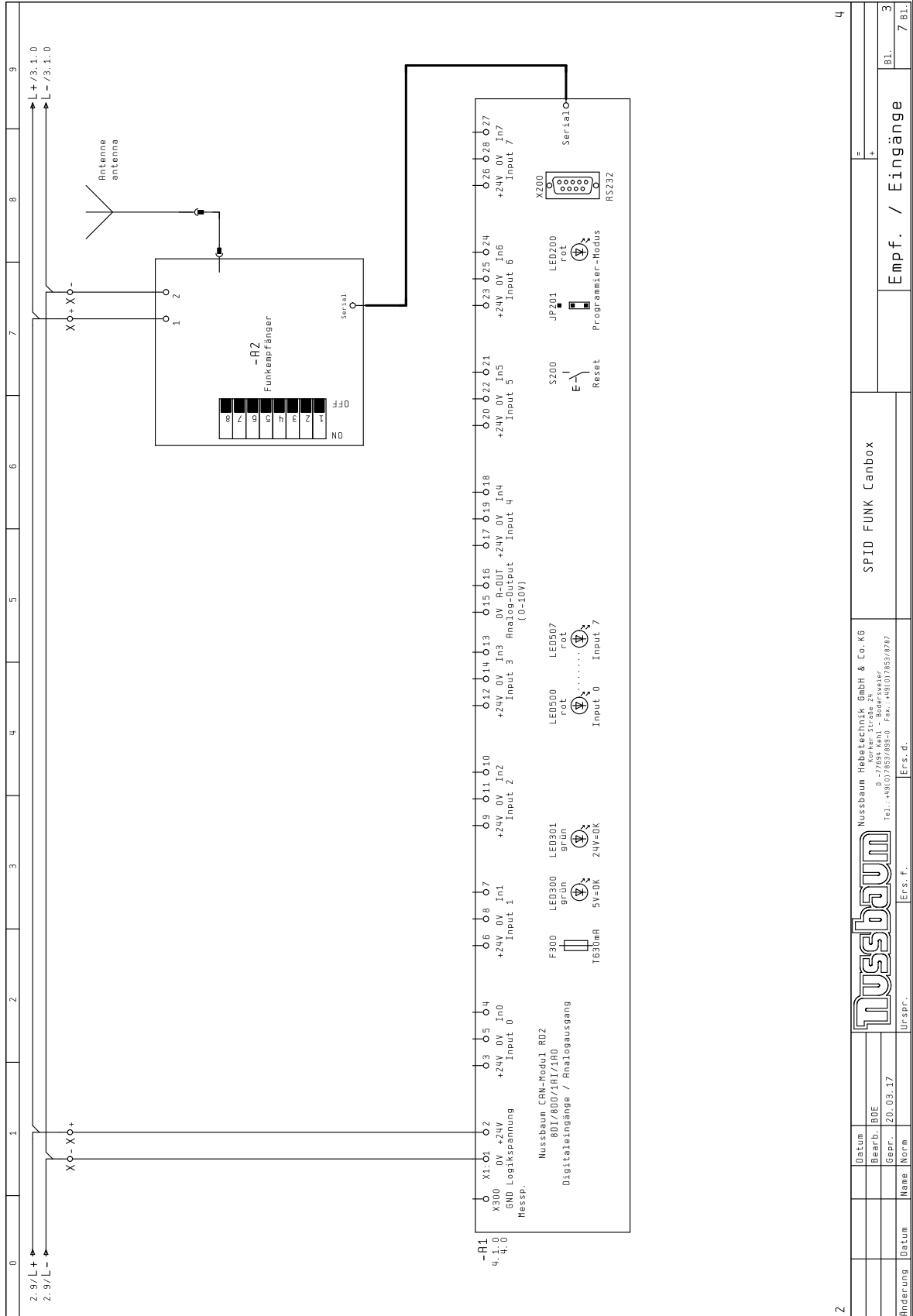

2		4	
Datum		SPID FUNK Canbox	
Bearb.	BDE	Nussbaum Hebe-technik GmbH & Co. KG	
Gepr.	ZD.03.17	D-77894 Kehl - Bodensee	
Name	Norm	Tel.: +49(0)7853/898-0 Fax.: +49(0)7853/897	
Datum		Ers. f.	
Erspr.		Ers. d.	
Empf. / Eingänge		=	
		+	
		3	
		Bl. 7 Bl.	

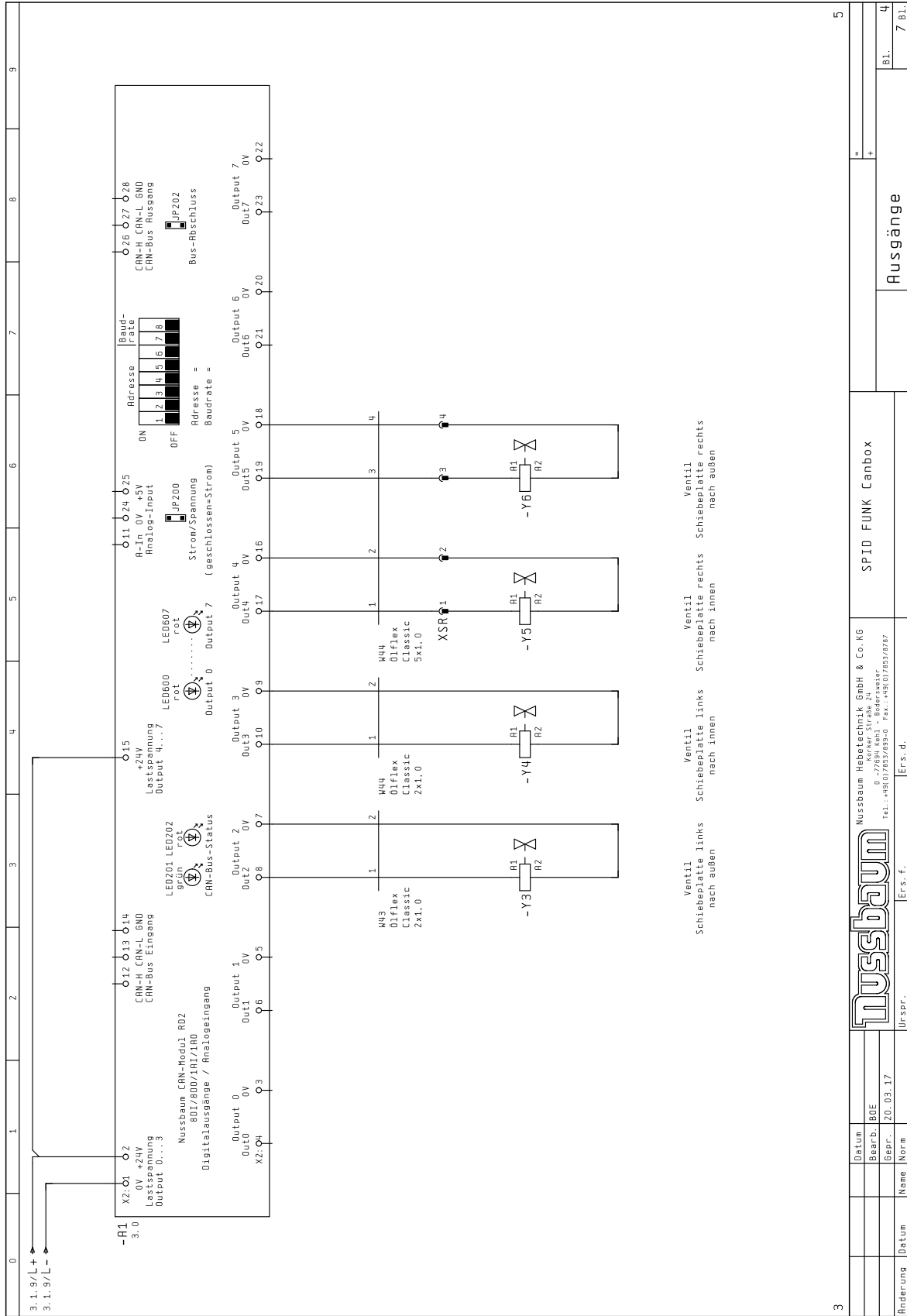







## 4. Safety regulations

If you use the automotive lift, the German following regulations are to be considered:  
BGG945: Examine of automotive-lifts; BGR500 Using automotive-lifts; (VBG14).

**Especially the following regulations are very important:**

- The laden weight of the lifted vehicle mustn't be more than 4000 kg for the automotive lift, 3500 kg for the automotive lift with wheel free lift.
- The laden weight of the lifted vehicle must not be more than 3500 kg for the wheel free lift.
- The maximal axle load must not be more than 2300 kg for the SPID.
- The automotive lift must be lowered completely, before the vehicle is driving, in the provided direction, on the lift.
- During working with the lift the operating instruction has to be followed.
- At vehicles with low sub-ground clearance or with optional equipment (sport equipment) or sport-vehicles, it is to be tested previously whether damages can appear.
- Only trained personnel over the age of 18 years old are to operate this lift.
- Position the polymer supports as described of the vehicle manufacturer under the vehicle. (Version with wheel free lift)
- The correct position of the polymer pads has to be checked after the vehicle has been lifted a little bit.
- It's not allowed to stay under the lifted or lowered vehicle (except for the operator).
- Check the center of gravity of the vehicle if heavy parts are removed. (Version with wheel free lift)
- It's not allowed to transport passengers on the lift or in the vehicle.
- It's not allowed to climb onto the lift or onto a lifted vehicle.
- The automotive lift must be checked from an expert after changes in construction or after repairing carrying pads.
- It's not allowed to start with operations at the lift before the main switch is switched off.
- During lifting or lowering the vehicle it must be observed from the operator.
- It's not allowed to install the standard-automotive lift in hazardous location or in washing bays.

## 5. Operating instructions



***The Safety Regulations must be observed during working with the automotive lift. Read the safety regulations in chapter 4 carefully before working with the lift!***

### 5.1 Lifting the vehicle

- Drive vehicle over the lift, longitudinal axes on line of the lift.



***(Wheel free lift): If necessary use the ramps to secure the safety ness of the vehicle.***

- Block the vehicle against rolling, put into gear, use the parking brake.
- Check the dangerous places of the lift and be sure that there are no objects or people in the immediate area of the lift or on the lift.
- Switch on the control system; main switch on position "1" (see pic.1)
- Choose between main lift/ wheel free lift (see pic.1, 4)

- (wheel free lift) Position the polymer supports under the pick-up points which are described by the vehicle manufacturer. Do not lay them on edge! The vehicle might fall down!
- Raise the lift. Press the button „lifting“.
- (wheel free lift): Stop the lifting when the wheels are free to check the safe position of the vehicle on the polymer pads.
- Lift the vehicle on the working height. Press the button „lifting“ .



*pic. 1: operation unit*

*1 main switch*

*2 button „lifting“*

*3 button „lowering“*

*4 reversing switch main lift/wheel free lift*

## 5.2 Lowering the vehicle

- Check the dangerous places of the lift and be sure that there are no objects or people in the immediate area of the lift or on the lift.
- Choose between main lift/ wheel free lift (see pic.1, 4)
- Lower the vehicle to the working height or until the platform reaches the lowest point; press the button „lowering“ .
- Observe the complete process.
- Before the lift reaches the lowest position, it stops (approx. 150 mm).  
Let off the „lowering“. Control the dangerous places. Press the button again. You hear an acoustic signal until the lift reaches the lowest position.
- When the lift is in its lowest position, remove the polymer supports (wheel free lift)
- Drive the vehicle out of the lift if the lift (main lift) is in the lowest position.

## 5.3 Equalization of the platforms

Because there are two independent hydraulic systems, differences between the two rails should normally not appear when you operate the lift correctly.  
Check possible mistakes before you equalize the two platforms (for instance a leakage of the hydraulic system or another external mistake)



***Equalize the rails only without load!  
Before an equalization you have to remove any kind of load of the lift!***

An equalization could be necessary when one side isn't let down completely into the lowest position or if the loads of the two rails are very different of each other, for example.

**Correct equalization:**

**Situation:** One rail is higher than the other.

**preparations/measures:**

- Lower the lift as far as possible into the lowest position. Press button „lowering“.



pic. 2: ball valves for the equalization of the lift.

- Remove the covers of the operation unit (back side)
- Pull ball valve KU1 and press button „lowering“. One rail lowers. Put button and ball valve in normal (original) position again.  
Pull ball valve KU2 and press button „lowering“. The second rail lowers also. Put button and ball valve in normal position again.
- Repeat this process for the wheel free lift with the ball valves KU3 and KU4.
- Lift the rails 1500 mm.
- Check now the position of the cylinder levers. All four cylinder levers have to sit close to the limit stops of the scissors. (compare to pic 3)

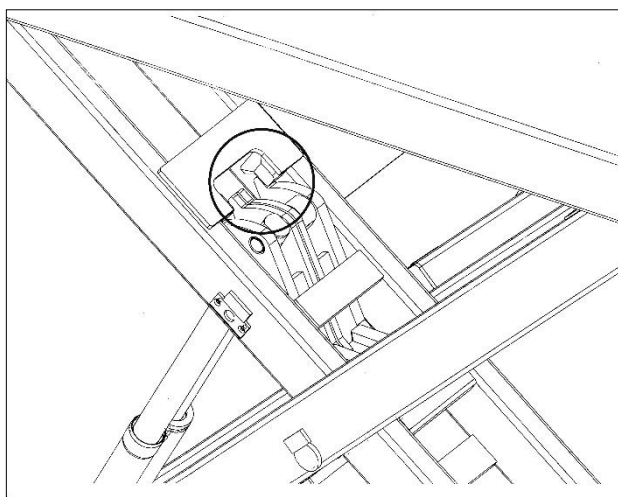

pic. 3  
cylinder levers (circle)  
2 x each side of the lift

- If the cylinder levers do not sit absolutely close to the limit stops then the rails have to be equalised still one time with the ball valves, according to the following description.
- **Equalization of the main lift:**  
Choose the main lift at the reversing switch (see pic.1, 4)

Press button „lifting“ and pull the ball valve KU1. Observe if the cylinder levers move to the limit stops. If no cylinder lever moves, put KU1 in his original position. Pull ball valve KU2 and press button „lifting“.

- **Equalization of the wheel free lift:**

Choose the wheel free lift (“RFH”) at the reversing switch (see pic.1, 4)

Lift the wheel free lift in the highest position. Check the rails for torsion.

Pull ball valve KU3 and press button „lowering“.

Observe the rails if one of them lowers. If no rail lowers, put KU3 in his original position and pull ball valve KU4. Push button „lowering“. The torsion should have disappeared.

If the rails have different heights, push the button „lowering“ until the rails of the wheel free lift have reached their lowest position. Hold the button „lowering“ pushed and pull the ball valves KU3 and KU4 until both rails are on the same level.

- Put the ball valves in their original position again.

## 6. Troubleshooting

If the lift does not work properly, the reason for this might be quite simple. Please check the lift for the potential reasons mentioned on the following pages. If the cause of trouble cannot be found, please call the technical service.

<b>Problem: Motor does not start!</b>	
<b>possible causes:</b>	<b>solution:</b>
<i>no power supply</i>	<i>let the power supply check</i>
<i>main switch is not engaged or defective</i>	<i>Check the main switch</i>
<i>The fee line is cut</i>	<i>Check the feed line and repair it</i>
<i>fuse defective</i>	<i>check fuse and replace it if necessary</i>
<i>thermal switch in the motor is active</i>	<i>let it cool down</i>
<i>Motor defective</i>	<i>Call the service partner</i>

<b>Problem: Motor starts, lift does not lifting!</b>	
<b>possible causes:</b>	<b>solution:</b>
<i>The vehicle is too heavy</i>	<i>Unload it</i>
<i>Level of the oil is too low</i>	<i>Fill new oil in</i>
<i>leakage of the hydraulic system</i>	<i>Check the hydraulic lines and repair it</i>
<i>gear pump does not work</i>	<i>call your service partner</i>

<b>Problem: The lift does not lower!</b>	
<b>possible causes:</b>	<b>solution:</b>
<i>The lift is standing on a obstacle</i>	<i>Push button „lifting“</i>
<i>hydraulic valve defect</i>	<i>call your service partner</i>
<i>fuse defective</i>	<i>check fuse and replace it if necessary</i>
<i>Button „lowering“ not pushed or defective</i>	<i>Push the correct button!</i>
<i>Seat valves cannot be unlocked</i>	<i>emergency lowering</i>

### 6.1 Driving on an obstacle

If the lift drives on an obstacle, the hydraulic system has got no more pressure and the lift stops. To remove the obstacle the lift has to rails have to be lifted a little. Therefore push button „lifting“ until the obstacle can be removed.

### 6.2 Emergency lowering of the main lift/ wheel free lift



**A emergency lowering is an intervention into the control of the lift and can be done only by experienced expert. The emergency lowering must be carried in this order. Otherwise a malfunction can lead it to damages or lead to danger for body and lives.**



**Every kind of external leakage must be removed. This is necessary particular before an emergency lowering.**

Reasons which provoke an emergency lowering are e.g. disturbances of the valves or a break-down of the power supply.

1. Disconnect the lift from the power supply before starting the emergency lowering.
2. Open the covers of the aggregate. You have to be able to reach the seat valves of the hydraulic bloc. (pic. 4)
3. Check the dangerous places of the lift and be sure that there are no objects or people in the immediate area of the lift or on the lift.
4. Emergency lowering of the main lift: press simultaneously the valves V1, V2.
5. Emergency lowering of the wheel free lift: press simultaneously the valves V3,V4.
6. The lowering starts immediately. If there is any danger, let off the valves and stop the emergency lowering!!

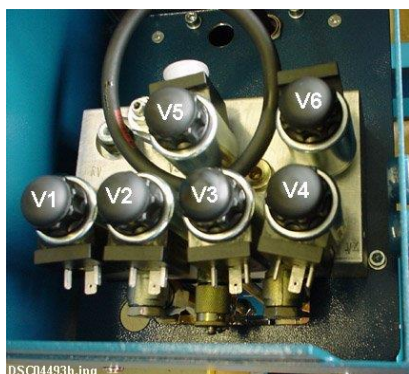

pic. 4  
*Valves with buttons for emergency lowering*



7. Lower the lift or the wheel free lift in his lowest position.
8. Observe the complete process.
9. Change the defect parts of the lift, before you initiate the lift again, if it is necessary. Therefore call your service partner.



**Switch off the main switch and lock it. Do not work with the lift until the faulty parts are exchanged.**

## 7. Inspection and Maintenance



**Before conducting maintenance work, preparations must be made to ensure that during maintenance and repair work there is no risk to the safety of people working on or around the lift and also that there is no risk of damage to equipment being used on or around the lift.**

To guarantee the utmost availability and to ensure that the lift remains functional, maintenance work contracts are organised between our clients and their local retailers.

A service must be performed at regular intervals of 3 months through the operator in accordance with following service manual. If the lift is in continuous operation or in a dirty environment, the maintenance rate must be increased.

During daily operation the lift must be closely observed to ensure that it is functioning correctly. In the case of malfunction or leakage the technical service must be informed.

### 7.1 Maintenance plan of the lift



**Before beginning any maintenance work isolate the power supply. Secure the main switch (lock it). Secure the danger area around the automotive lift and secure the lift against unintentional lowering.**

Maintenance plan	Period
Clean the piston rods of the hydraulic cylinders from sand and dirt. Clean and check the stripper of the cylinder. Grease the piston rods with a high capacity lipid (approx. 5 g of S2 DIN51503 KE2G of the Renolit Company).	min. once in a year
Clean and lubricate the moving parts of the lift (hinge bolts, sliding pieces, sliding surfaces) grease with a multipurpose lipid (example: Auto Top 2000 LTD. Agip).	min. once in a year
Grease all lubricate nipples with a multipurpose lipid. (example: Auto Top 2000 LTD. Agip).	min. once in a year
Check the hydraulics-hoses for leakage. Check the hydraulic hoses and fitting screws	min. once in a year
Check the oil level. Fill in a clean, high quality oil (32 cst) in the oil tank.	min. once in a year

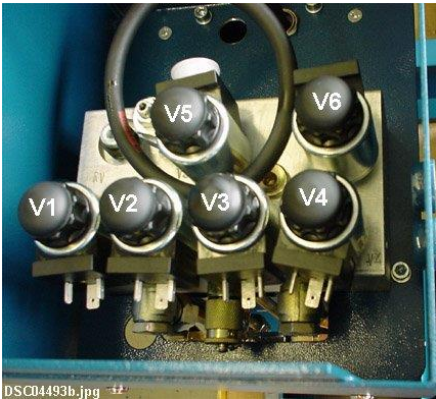
<p>The hydraulic oil has to be changed at least once a year. To change the oil, lower the lift into the lowest position. Empty the tank and replaced clean oil, approx. 14 litres are needed. A high quality hydraulic oil is recommended, it should be 32 cst. (e.g. HLP 32 LTD. OEST Company) Use a ATF-Suffix hydraulic-oil (OEST Company ) if the ambient temperature is under 5 degree centigrade. After the fill up, the hydraulic oil must be between the upper and low marking of the oil level gauge.</p>	<p>min. once in a year</p>
<p>Check the Polymer supports and replace them if its necessary.</p>	<p>min. once in a year</p>
<p>Check the condition and function of the safety devices of the lift. (CE-Stop + acoustic signal, ramps, roll over safety device, roll back safety device)</p>	<p>min. once in a year</p>
<p>Check all welded joints for cracks on the automotive-lift. If any cracks are found on the lift cease use immediately. Switch-off and secure the main switch (lock) and call the service partner.</p>	<p>min. once in a year</p>
<p>The valves (cartridges) have to be tightened with approx. 30 – 35 Nm in regular intervals. (see attachment) With intensive utilization of the lifting platform, the maintenance interval has to be curtailed.</p> <p>Before the cartridges with the demanded turning moment can be tightened, the coils have to be removed through releasing the black turn-lock fastener.</p> 	<p>min. once in a year</p>
<p>Damage to external surfaces, must be immediately repaired. If theses repairs are not made immediately, permanent damage to the powder-coated surface may result. Repair and clean damaged areas with an abrasive paper (grain 120). After this is complete, use a suitable paint (observe the RAL Number).</p>	<p>min. once in a year</p>
<p>Check the zinc surface and repair it with a suitable tool. Use abrasive paper (grain 280). White rust can result from moisture laying in certain areas for long</p>	<p>min. once in a year</p>

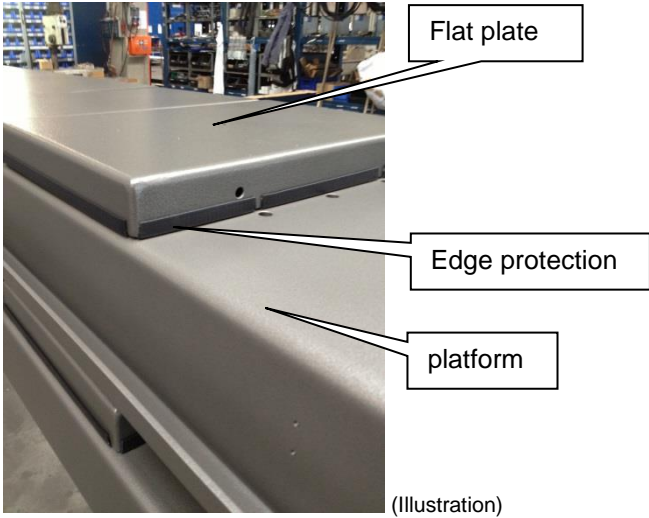
<p>periods of time. Poor aerating can also result in rust formation. Rust may result from mechanical damage, wear, aggressive sediments (de-icing salt, liquids) or insufficient cleaning. Repair and clean these areas with abrasive paper (grain 280). After this is complete, use a suitable paint (observe the RAL Number).</p>	
<p>Every liquids in foundation pits has to be removed and disposed of properly. The pits are to be kept dry. Raise the lift out of the pit when you not use the lift. The foundation surfaces can dry.</p>	min. once in a year
 <p>(Illustration)</p> <p>The black edge protection is a wear part. Check the condition in regular intervals. In case of damage and wear exchange it.</p> <p>We recommend the edge protection 1-2mm Order-Nr.: 971027 (Specify number of meters)</p>	min. once in a year
<p>Durability of the hydraulic hoses: The use duration of the hose lines should not exceed six years, including a storage time of at most two years.</p>	min. every sixth year
<p>Check the function and condition of all electrical parts. (cables, buttons)</p>	min. once in a year
<p>Check that all screws and bolts are correctly torque (turning moments, see the list).</p>	min. once in a year

Turning moment for screws  
property class 8.8

	0,10*	0,15**	0,20***
M8	20	25	30
M10	40	50	60
M12	69	87	105
M16	170	220	260
M20	340	430	520
M24	590	740	890

property class 10.9

	0,10*	0,15**	0,20***
M8	30	37	44
M10	59	73	87
M12	100	125	151
M16	250	315	380
M20	490	615	740
M24	840	1050	1250

Drehmomenttabelle 8.8-10.9 E

- \* sliding friction 0,10 for very good surfaces, lubricated
- \*\* sliding friction 0,15 for good surfaces, lubricated oder dry
- \*\*\* sliding friction 0,20 surface black or phosphatized, dry

## 7.2 Cleaning of the automotive lift

A regular and appropriate maintenance practice will aid the preservation of the lift.

No guarantees can be given when damage (egg rust or fading colour) is the direct result of poor maintenance and cleaning practice.

Regular cleaning of all kinds of dirt is the best protection against wear and the formation of rust and will prolong the life of the lift

- Dirty deposits that can cause rust include:

- de-icing salt
- sand, pebble stone, natural soil
- all types of industrial dust
- water; also in connection with other environmental influences
- all types of aggressive deposits
- constant humidity caused by insufficient ventilation

Obviously this is dependent on the type of work being done with the lift, the degree of cleanliness of the workshop and location of the lift. The degree and amount of dirt is dependent on the season, on the weather conditions and the ventilation of the workshop.

During poor conditions it may be necessary to clean the lift once week, but cleaning once a month will suffice.

Clean the lift and the floor with a non-aggressive and non-abrasive detergent. Use a gentle detergent to clean the parts. Use an standard washing-up liquid and lukewarm water.

- Do not use steam jet cleaners.
- Remove all dirt carefully with a sponge or if necessary with a brush.
- Ensure that no washing-up liquid is left on the lift after cleaning.
- Do not use aggressive means for cleaning the workshop floor and the automotive lift.
- A permanent contact with any kind of liquid is not allowed. Do not use high pressure devices for cleaning the lift.
- After cleaning dry the automotive-lift with a suitable type of cloth and inject it with a wax spray or an oil spray.

## 7.3 Cleaning and care of galvanised surfaces

*Excerpt from DIN EN ISO 1461: "Zinc coatings on steel using hot-dip galvanising"*

*"The main purpose of the zinc coating is to protect the iron and steel material lying underneath from corrosion. Considerations of aesthetics and decorative properties should take second priority. . . . It should be observed that "roughness" and "smooth" are relative terms and the roughness of piece galvanised coatings can differ from continuous hot-dipped galvanised products, as for example continuous hot-dipped galvanised sheet metal, pipe and wire.*

*In practice it is not possible to specify a definition for the uniformity and the surface qualities of zinc coatings.*

*The occurrence of dark or light areas (e.g. lattice pattern or dark-grey areas) or a slight surface unevenness is no reason for rejection. The formation of (white or dark) corrosion products, mainly consisting of zinc oxide (occurring from storage in damp conditions after the hot-dip galvanising), is no reason for rejection as long as the required minimum thickness value of the zinc coating is still present.*

*For touch-up work:*

*"The sum of the areas without coating that must be touched-up must not exceed 0.5% of the total surface of a single part. A single area without coating must not exceed an area of 10 cm<sup>2</sup>. . . .*

*The touch-up work should be done through thermal spraying with zinc (e.g. ISO 2063) or through a suitable zinc powder coating, where the zinc dust pigment must comply with ISO 3549 within the practical limits of such systems, or using suitable zinc-flake coating or zinc paste. .. A sufficient corrosion protection must be ensured on the touched-up areas." The touch-up work must always be at least 100 µm thick.*

*Excerpt from GSB ST 663: Visual assessment of the surface:*

Source: Quality and inspection regulations for industrial hot-dip galvanising, part 663: "International quality guidelines for part coating on steel and hot-dipped galvanised steel"

*"The assessment of the decorative appearance of the surface in regards to uniformity of colour and structure must be done without auxiliary aids; for external parts at a distance of at least 5 m, for interior parts at a distance such as at least 3 m vertical with diffused lighting. All parts must basically match in gloss, colour and structure. Foundation unevenness, for example scratches, grinding marks, corrosion scars and welding seams have no significance in the assessment of the coating quality."*

### **Influence factors for discolourations of the surface**

Source: Hot-dipped galvanised: Newsletter for users no. 5

*The protective effect of the durable hot-dipped galvanising is based on the formation of cover layers which, due to weathering influences in the course of weeks or months, occur on the galvanised surface. The cover layers mainly occur from basic zinc carbonate. If the zinc surface is sprayed with water over an extended period or if the air access and thus the presence of CO<sub>2</sub> insufficient, then the occurrence of protective cover layers is prevented. Instead, so-called "white rust" forms on the surface of galvanised parts.*

*White rust consists mainly of zinc hydroxide and slight proportions of zinc oxide and zinc carbonate. In practice white rust can only become a problem with freshly hot-dipped galvanised parts. The formation of white rust has no connection with the galvanising process and is not a measure for the quality of the galvanisation. The probability for possible white rust formation fluctuates depending on the weather in the course of a year. White rust occurs more frequently in autumn and winter. Frequent precipitation in the form of rain and snow, fog and dropping below the dew point due to low temperatures promotes possible white rust formation.*

Aggressive liquids, for example salts, brake fluids, chemical additives or acids have a negative effect on the zinc layer. If they come in contact with the zinc galvanised surface they must be removed immediately and the area cleaned (see the chapter Cleaning and Care)

### **Touch-up after incidence of white rust:**

- With only a slight incidence, the removal of white rust is not absolutely necessary.
- With a strong incidence, smaller areas can be removed with a special brush (e.g. made of soft bronze wire, brass or a plastic brush). Be careful, if brushed too intensively the surface can become dark.
- If necessary, zinc and stainless steel cleaner (e.g. Leraclen ZNR) can be used.

### **Traces of usage due to tyre wear**

Traces of usage due to tyre wear result in an unattractive surface on the drive rail. These have nothing to do with the quality of the galvanising. (see point Cleaning and Care)

### **Spotting due to spilling liquids**

See point Cleaning and Care

### Cleaning and care

- Regularly clean the galvanised parts (and immediately after contact with aggressive substances) with plenty of clean water.
- If necessary the surface must be brushed off with a special brush and with slight pressure
- Let the surface dry well!  
The drive rail must be free during this, there must be no vehicle on the lift.
- Seal the surface with a temporary corrosion protection against recurrence of the white rust.  
For this use acid-free oils, greases or waxes

## 8. Security check

The security check is necessary to guarantee the safety of the lifting during use. It has to be performed in the following cases:

1. Before the initial operation, after the first installation  
**Use the form "First security check before initiation"**
2. In regular intervals after the initial operation, at least annually.  
**Use the form "Regular security check at least annually"**
3. Every time the construction of that particular lift has been changed.  
**Use the form "Extraordinary security check"**



***The first and the regular security check must be performed by a competent person. It is recommended to service the lift at this occasion.***



***After the construction of the lift has been changed (changing the lifting height or capacity for example) and after serious maintenance works (welding on carrying parts) an extraordinary security check must be performed by an expert.***

This manual contains form with a schedule for the security checks. Please use the adequate form for the security checks. The form should remain in this manual after they have been filled out. In the following there is a short description about special safety devices.

## 9. Installation and Initiation

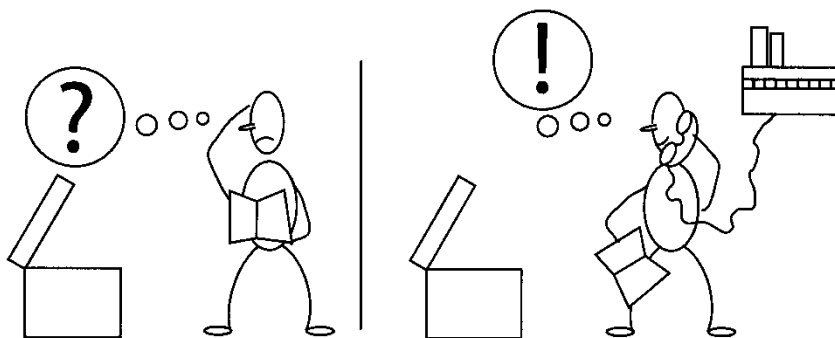



## 9.1 Regulations for the installation

- The installation of the lift is performed by trained technicians of the manufacturer or one of its distribution partners. If the operator can provide trained mechanics, he or she can install the lift by him or herself. The installation has to be done according to this regulation.
- Installing the standard-automotive lift in a hazardous location or a washing bay is not allowed.
- Before installation a sufficient foundation must be constructed. If the foundation is already constructed then proof that the foundation conforms to the standard is required. A level foundation for the installation is required. The foundations must be based in a frost resistance depth, both outdoors and indoors in a position where the installer believes there is no chance of frost.
- An electrical supply 3~/N+PE, 400 V, 50 Hz must be provided. The supply line must be protected with a time-lag fuse T16A (VDE0100 German regulation). The minimum diameter amounts to 2.5 mm<sup>2</sup>.
- All cable ducts must be equipped with protective coverings to prevent accidents.
- After assembly of the lift, the protective grounding of the lift must be examined after International Electrotechnical Commission (IEC) guidelines (60364-6-61) before first start-up by operators. Also an insulation resistance examination is recommended.

## 9.2 Erection and doweling of the lift

- Install the lift according to the data sheet and the foundation plan.
- Install the operating unit at its designed place. Connect the power supply.
- Connect the hydraulic. All hoses are marked.
- Fill in the hydraulic oil, approx. 14 litres are needed. A high quality hydraulic oil is recommended, it should be 32 cst. (e.g. HLP 32 LTD. OEST Company) After the fill up, the hydraulic oil must be between the upper and low marking of the oil level gauge.
- Push button „lifting“ until the vent screws (on the top of the slave cylinders, see pic. 5) can be reached. Execute a deaerate according to chapter 9.6, if necessary.
- Adjust the lift: first one base plate, than the second base plate. If there is an uneven floor even it with metal sheets. A continuous contact between the floor and the base plate must be guaranteed to avoid hollow spaces. Dowel the lift:  
Nussbaum Company recommended Liebig, Fischer, Hilti safety dowels (german dowel manufacturer) or equivalent dowels of other manufacturer but: observe their regulations. Before doweling check the concrete floor (with quality min. C20/25) if the concrete floor goes to the top edge of the floor. For an existing concrete floor the dowels have to be chosen according to pic. 8. If floor tiles are on the concrete floor, the dowels have to be chosen according pic. 9. Its important for the trouble-free working that the base plate are clean and the guides of the sliding block are clean and greased.  
Check the adjustment of the base plates and dowel the lift: Bore the holes to fix the dowels through the borings of the base plates. Clean the holes with pressure air. Put in the safety dowels.
- Dowel the aggregate in the floor.
- Tighten the dowels with the dynamometric key.



**Each dowel must be tightened with the demanded torque. Otherwise the normal and secure function of the lift can not guaranteed. Observe the regulations of the other dowel-manufacturer.**

- Raise and lower the lift several times with load. Check the torque of the dowels and check the hydraulic hoses tightness.
- Equalize the lift, if this is necessary.
- Mount the covers: Do not damage the cables.

### 9.3 Deaerate the hydraulic system (main lift)

- The correct power supply, the correct hydraulic oil and the closeness of the hydraulic system have to be controlled after the installation of the lift.

By connecting the hydraulic hoses, air might enter the hydraulic system and provoke problems of ganging. In consequence a deaerating is necessary.

Check again the correct installation of the hydraulic hoses!

**Effects**, which make a deaerating necessary are e.g. a sudden lifting out of the lowest position or unequal rails.

Correct deaerating:

There have to be 14 litres of hydraulic oil filled in the oil tank.

- Choose the main lift at the reversing switch (see pic.1, 4)
- Open the vent screws on the top of the slave cylinders (see pic. 5) a little bit. Do not open them completely.
- Push button „lifting“. The air streams out of the borings on the slave cylinders. Keep the screws open until only hydraulic oil comes out of the borings. Close the vent screws afterwards.

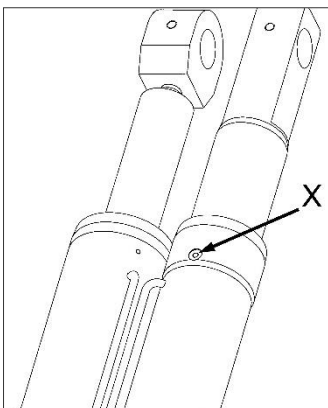

pic. 5

pos. X = vent screw on the top of the slave cylinders



**If you do not close the vent screws, trouble and disturbances of the lift will occur!**

- Push button „lifting“ and drive the lift into the highest position. Repeat the procedure of deaerating, if necessary.
- Check if the vent screws are closed

- Push button „lowering“ and drive the lift into the lowest position. (While you lower the lift it is possible that the oil-air mix makes sounds)
- Lift the rails on 1500 mm without load. Check up the holding time.
- Check again the position of the cylinder levers.

## 9.4 Initiation



**Before the initiation a security check must be performed. Therefore use form: First security check.**

If the lift is installed by a competent person, he will perform this security check. If the operator installs the lift by himself, he has to instruct a competent person to perform the security check.

The competent confirms the faultless function of the lift in the installation record and form for the security check and allows the lift to be used.



**Please send the filled installation record to the manufacturer after the installation.**

## 9.5 Changing the installation place

If the place of installation shall be changed, the new place has to be prepared in according to the regulations of the first installation. The changing should be performed in accordance with the following points:

- Raise the lift on approx. 1000 mm.
- Remove the cover of the hydraulic tubes.
- Loose the dowels.
- Lower the lift in the lowest position.
- Loose the plug of the power supply.
- If necessary loose the hydraulic hoses only on the operating unit.
- If necessary use blind plugs to close the hoses.
- Disconnect the power supply.
- Transport the lift to its new place.
- Install the lift in accordance with chapter 9 “Installation and Initiation”.
- Equalize and deaerate the lift!



**Use new dowels, the used dowels can not be used anymore.**



**A security check must be performed before reinitiation by a competent person. Use form “Regular security check”**

**Pic. 6: choice of the dowel length without floor pavement or tile surface**

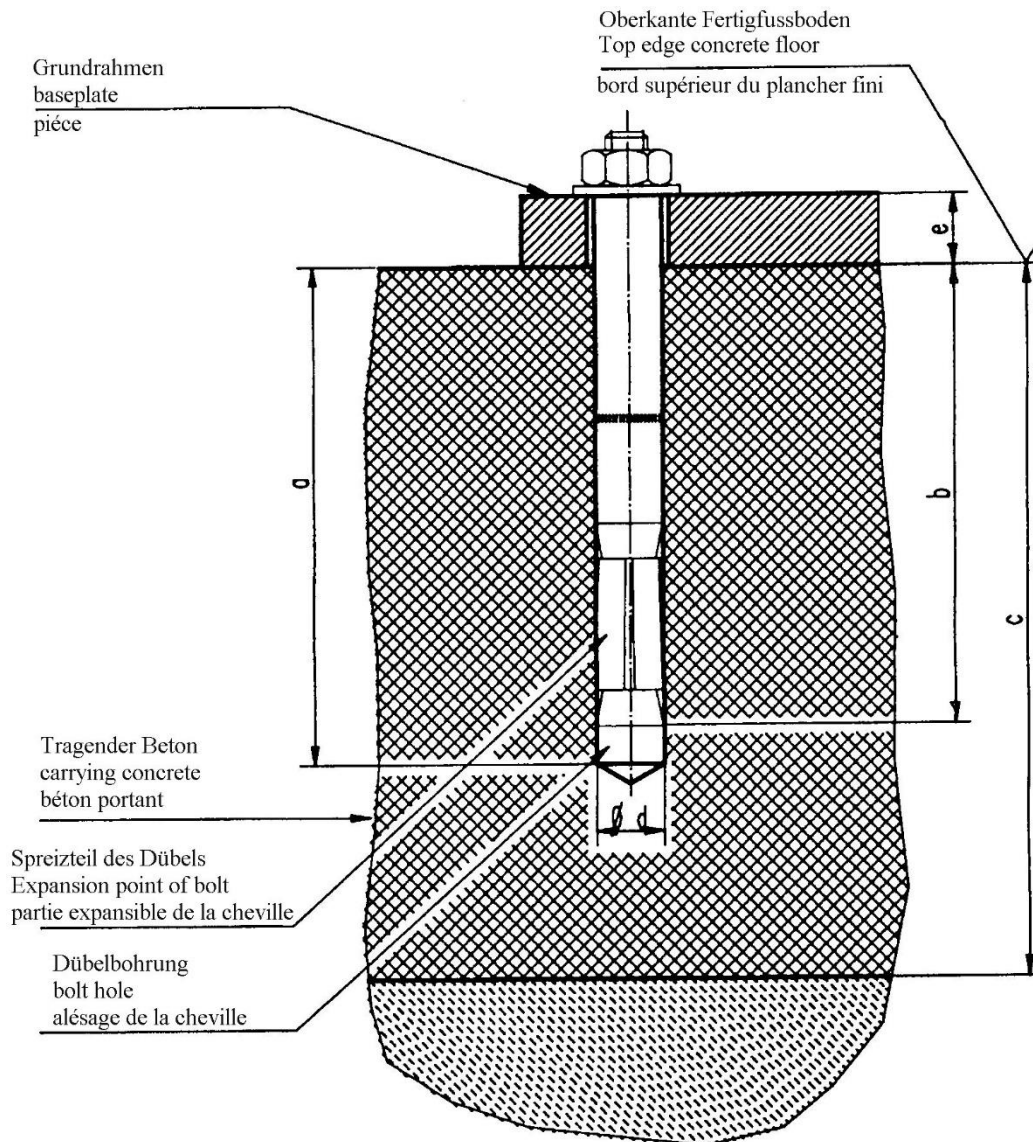

Liebig-dowels	
Dowel type	BM12-20/80/40
Drilling depth	a 100
Min. anchorage depth	b 80
Thickness of concrete	c min.160(*)
Diameter of bore	d 20
Thickness of the lift-pieces	e 0-40
Number of dowels	16
Starting torque	70

**(\*) minimum thickness of concrete by using the mentioned dowels. Otherwise, observe the regulation of the foundation plan.**

**You can use equivalent dowels from another dowel manufacturer (with license) but observe their regulation.**



**Pic 7: choice of the dowel lengths ( without floor pavement or tile surface)**

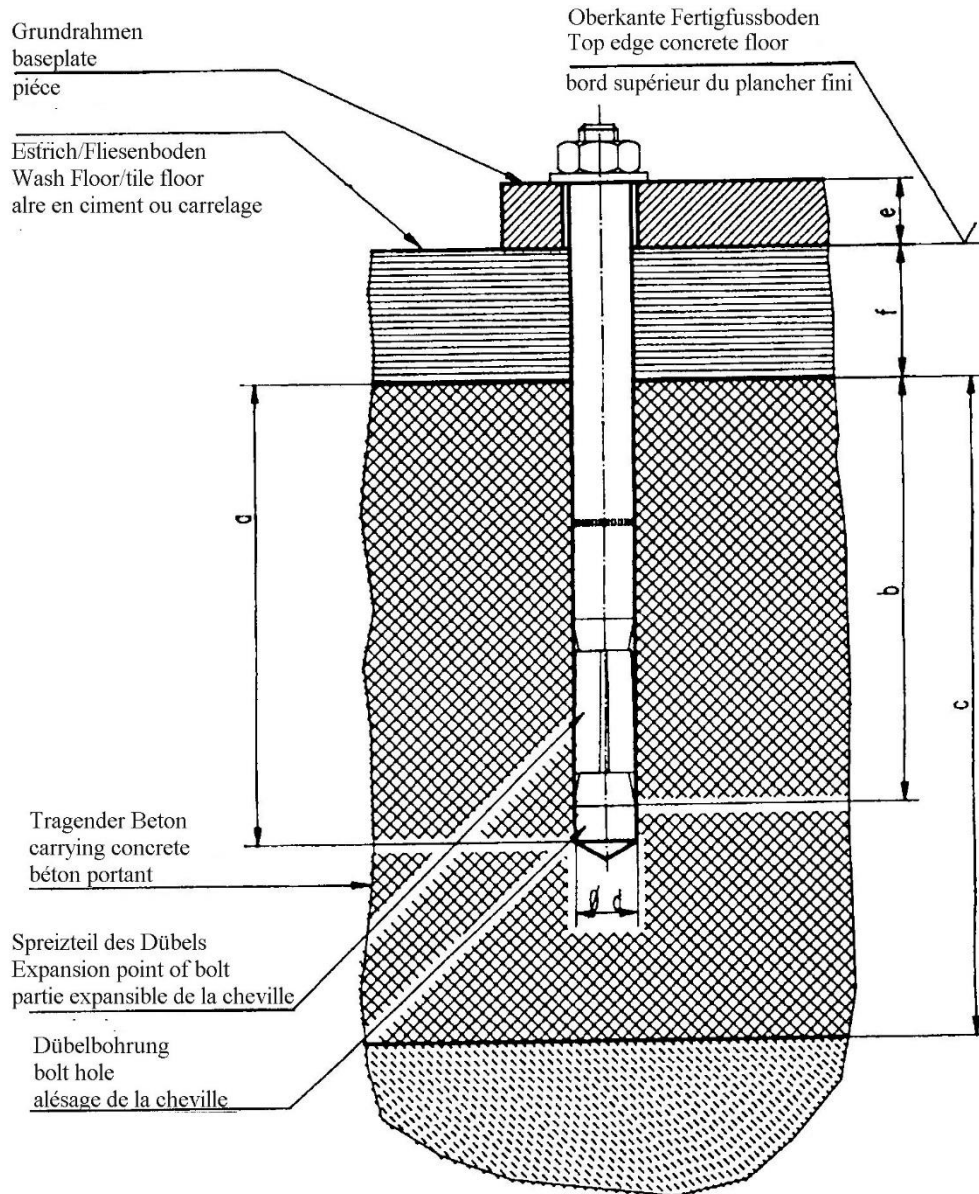

**Liebig-dowels**

Dowel type		BM12-20/80/65	BM12-25/80/100	BM12-20/80/140
Drilling depth	a	100	100	100
Min. anchorage depth	b	80	80	80
Thickness of concrete	c	min.160(*)	min.160(*)	min.160(*)
Diameter of bore	d	20	20	20
Thickness of the lift-pieces	e+f	40-65	65-100	100-140
Number of dowels		16	16	16
Starting torque		70 Nm	70Nm	70Nm

**(\*) minimum thickness of concrete by using the mentioned dowels. Otherwise, observe the regulation of the foundation plan.**

**You can use equivalent dowels from another dowel manufacturer (with license) but observe their regulation.**

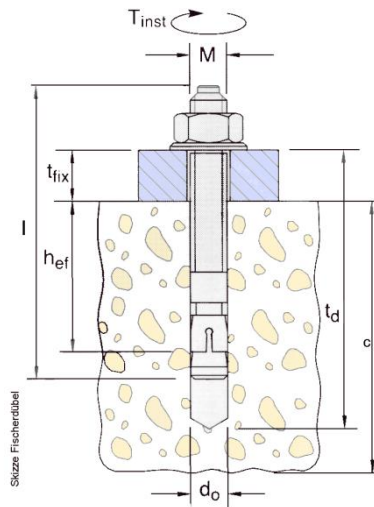

Änderungen vorbehalten!  
subject to alterations!  
sous réserve des modifications!

<b>fischer-Dübel</b>		UNI LIFT 3500 NT/CLT <sup>d</sup>		
Dübel typ of dowel type de cheville		FH 15/50 B Bestellnr. 970265	FH 18 x 100/100 B Bestellnr. 972230	FH 24/100 B Bestellnr. 970267
Bohrtiefe drilling depth Profondeur de l'alésage	t <sub>d</sub>	145	230	255
Mindestverankerungstiefe min.anchorage depth Profondeur minimale d'ancrage	h <sub>ef</sub>	70	100	125
Betonstärke thickness of concrete Épaisseur du béton	c	siehe den aktuellen Fundamentplan see current foundation-diagram drawing vois le plan de fondation actuel		
Bohrerdurchmesser diameter of bore Diamètre de l'alésage	d <sub>o</sub>	15	18	24
Bauteildicke thickness of the lift-piece Épaisseur de la pièce	t <sub>fix</sub>	0-50	0-100	0-100
Anzugsdrehmoment Nm turning moment moment d'une force	M <sub>d</sub>	40	80	120
Gesamtlänge Total length Longueur totale	l	155	230	272
Gewinde Thread fil	M	M10	M12	M16
Stückzahl piece number nombre des pièces	a	4		
	b	8		
	c	10		
	d	12		
	e	16		
	f	20		

**Montage**

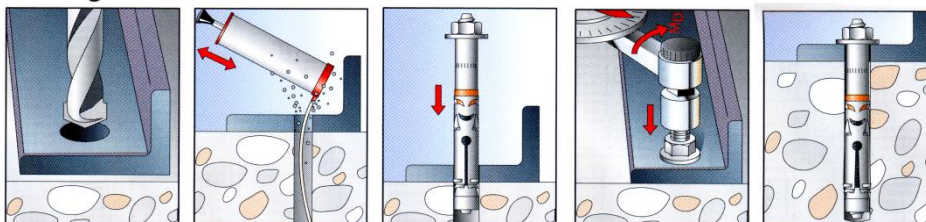

Es können auch gleichwertige Sicherheitsdübel anderer Hersteller (mit Zulassung) unter Beachtung deren Bestimmungen verwendet werden.  
It is possible to use equivalent safety-dowels (with license) of other manufacturer but observe their regulations.  
Des chevilles des autres marques (autorisées) peuvent aussi être choisies en respectant les directives du fabricant.

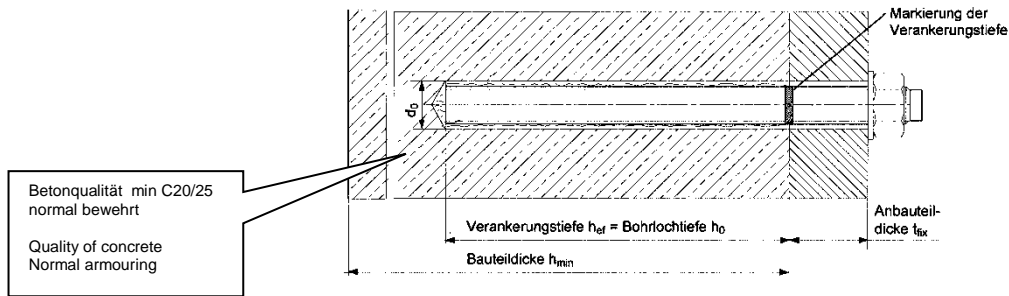

Änderungen vorbehalten!  
subject to alterations!  
sous réserve des modifications!

<b>Hilti-Injektionsdübel</b>				
Betonboden / concrete floor		ohne Bodenbelag / without floor pavement (tiles)		
Dübel type of dowel type de cheville		HIT-V-5.8 M10x130	HIT-V-5.8 M12x150 Art.Nr.387061	HIT-V-5.8 M16x200 Art.Nr.956437
Bohrtiefe (mm) drilling depth Profondeur de l'alésage	<b>h<sub>0</sub></b>	90	110	125
Mindestverankerungstiefe (mm) min.anchorage depth Profondeur minimale d'ancrage	<b>h<sub>ef</sub></b>	90	110	130
Betonstärke (mm) thickness of concrete Epaisseur du béton	<b>H<sub>min</sub></b>	min. 120	min. 140	min. 170
Bohrerdurchmesser (mm) diameter of bore Diamètre de l'alésage	<b>d<sub>0</sub></b>	12	14	18
Bauteildicke (mm) thickness of the lift-piece Epaisseur de la pièce	<b>t<sub>fix</sub></b>	max. 23	max. 21	max. 52
Anzugsdrehmoment (Nm) turning moment moment d'une force	<b>T<sub>inst</sub></b>	20	40	80
Gesamtlänge (mm) Total length Longueur totale	<b>l</b>	130	150	200
Gewinde Thread fil	<b>M</b>	10	12	16
Stückzahl piece number nombre des pièces	a	4		
	b	8		
	c	10		
	d	12		
	e	14		
	f	16		
	g	28		
Die Montageanweisung des Dübelherstellers ist Folge zu leisten. Bei Bodenbelag (Estrich/Fliesen) sind längere Dübel zu verwenden. Observe necessarily the installation description of the dowel manufacturer. Use longer dowels with version with floor pavement and tiles				
Es können auch gleichwertige Injektionsdübel anderer Hersteller (mit Zulassung) unter Beachtung deren Bestimmungen verwendet werden. It is possible to use equivalent injections dowels (with license) of other manufacturer but observe their regulations. Des chevilles des autres marques (autorisées) peuvent aussi être choisies en respectant les directives du fabricant.				
Die Daten wurden aus den von Hilti bereitgestellten Unterlagen entnommen. Hierfür übernehmen wir keine Garantie.				



**First security check before installation**



Filling out and leave in this manual

Serial number: \_\_\_\_\_

kind of check	all right	defect missing	verification	remark
Short Operating instruction.....	<input type="checkbox"/>	<input type="checkbox"/>	<input type="checkbox"/>	.....
Type plate.....	<input type="checkbox"/>	<input type="checkbox"/>	<input type="checkbox"/>	.....
Warning designation, sticker.....	<input type="checkbox"/>	<input type="checkbox"/>	<input type="checkbox"/>	.....
Function button "lifting/lowering".....	<input type="checkbox"/>	<input type="checkbox"/>	<input type="checkbox"/>	.....
Function lever „main lift/wheel free lift“.....	<input type="checkbox"/>	<input type="checkbox"/>	<input type="checkbox"/>	.....
Condition / Function ramp.....	<input type="checkbox"/>	<input type="checkbox"/>	<input type="checkbox"/>	.....
Function play-detector (optional).....	<input type="checkbox"/>	<input type="checkbox"/>	<input type="checkbox"/>	.....
Condition/Function pocket-lamp (optional).....	<input type="checkbox"/>	<input type="checkbox"/>	<input type="checkbox"/>	.....
Security of the bolts.....	<input type="checkbox"/>	<input type="checkbox"/>	<input type="checkbox"/>	.....
Condition bolts and bearings.....	<input type="checkbox"/>	<input type="checkbox"/>	<input type="checkbox"/>	.....
Condition sliding blocks.....	<input type="checkbox"/>	<input type="checkbox"/>	<input type="checkbox"/>	.....
Condition colour.....	<input type="checkbox"/>	<input type="checkbox"/>	<input type="checkbox"/>	.....
Construction (deformation, cracking).....	<input type="checkbox"/>	<input type="checkbox"/>	<input type="checkbox"/>	.....
Condition quality of concrete (cracking).....	<input type="checkbox"/>	<input type="checkbox"/>	<input type="checkbox"/>	.....
Torque moment of the dowels.....	<input type="checkbox"/>	<input type="checkbox"/>	<input type="checkbox"/>	.....
Fixed seat of the screws.....	<input type="checkbox"/>	<input type="checkbox"/>	<input type="checkbox"/>	.....
Condition operating unit.....	<input type="checkbox"/>	<input type="checkbox"/>	<input type="checkbox"/>	.....
Condition piston rod and stripper.....	<input type="checkbox"/>	<input type="checkbox"/>	<input type="checkbox"/>	.....
Condition of the covers.....	<input type="checkbox"/>	<input type="checkbox"/>	<input type="checkbox"/>	.....
Condition of hydraulic system and screw fittings.....	<input type="checkbox"/>	<input type="checkbox"/>	<input type="checkbox"/>	.....
Level of hydraulic oil .....	<input type="checkbox"/>	<input type="checkbox"/>	<input type="checkbox"/>	.....
Condition hydraulic hoses .....	<input type="checkbox"/>	<input type="checkbox"/>	<input type="checkbox"/>	.....
Condition electrical cables, switches .....	<input type="checkbox"/>	<input type="checkbox"/>	<input type="checkbox"/>	.....
Function test with vehicle.....	<input type="checkbox"/>	<input type="checkbox"/>	<input type="checkbox"/>	.....
Function test wheel free lift with vehicle.....	<input type="checkbox"/>	<input type="checkbox"/>	<input type="checkbox"/>	.....
Condition Polymer supports.....	<input type="checkbox"/>	<input type="checkbox"/>	<input type="checkbox"/>	.....
Condition welding.....	<input type="checkbox"/>	<input type="checkbox"/>	<input type="checkbox"/>	.....
Function CE-Stop + warning signal.....	<input type="checkbox"/>	<input type="checkbox"/>	<input type="checkbox"/>	.....

**( mark here applicable, in case of verification mark in addition to the first mark!)**

Security check carried out:.....

Carried out the company:.....

Name, address of the competent:.....

Result of the Check:

- Initiation not permitted, verification necessary
- Initiation possible, repair failures until.....
- No failings, Initiation possible

.....  
signature of the expert

.....  
signature of the operator

If failures must be repaired:

Failures repaired at: .....  
(Use another form for verification!)

.....  
signature of the operator

**Regular security check**



Filling out and leave in this manual

Serial number: \_\_\_\_\_

kind of check	all right	defect missing	verification	remark
Short Operating instruction.....	<input type="checkbox"/>	<input type="checkbox"/>	<input type="checkbox"/>	.....
Type plate.....	<input type="checkbox"/>	<input type="checkbox"/>	<input type="checkbox"/>	.....
Warning designation, sticker.....	<input type="checkbox"/>	<input type="checkbox"/>	<input type="checkbox"/>	.....
Function button "lifting/lowering".....	<input type="checkbox"/>	<input type="checkbox"/>	<input type="checkbox"/>	.....
Function lever „main lift/wheel free lift“.....	<input type="checkbox"/>	<input type="checkbox"/>	<input type="checkbox"/>	.....
Condition / Function ramp.....	<input type="checkbox"/>	<input type="checkbox"/>	<input type="checkbox"/>	.....
Function play-detector (optional).....	<input type="checkbox"/>	<input type="checkbox"/>	<input type="checkbox"/>	.....
Condition/Function pocket-lamp (optional).....	<input type="checkbox"/>	<input type="checkbox"/>	<input type="checkbox"/>	.....
Security of the bolts.....	<input type="checkbox"/>	<input type="checkbox"/>	<input type="checkbox"/>	.....
Condition bolts and bearings.....	<input type="checkbox"/>	<input type="checkbox"/>	<input type="checkbox"/>	.....
Condition sliding blocks.....	<input type="checkbox"/>	<input type="checkbox"/>	<input type="checkbox"/>	.....
Condition colour.....	<input type="checkbox"/>	<input type="checkbox"/>	<input type="checkbox"/>	.....
Construction (deformation, cracking).....	<input type="checkbox"/>	<input type="checkbox"/>	<input type="checkbox"/>	.....
Condition quality of concrete (cracking).....	<input type="checkbox"/>	<input type="checkbox"/>	<input type="checkbox"/>	.....
Torque moment of the dowels.....	<input type="checkbox"/>	<input type="checkbox"/>	<input type="checkbox"/>	.....
Fixed seat of the screws.....	<input type="checkbox"/>	<input type="checkbox"/>	<input type="checkbox"/>	.....
Condition operating unit.....	<input type="checkbox"/>	<input type="checkbox"/>	<input type="checkbox"/>	.....
Condition piston rod and stripper.....	<input type="checkbox"/>	<input type="checkbox"/>	<input type="checkbox"/>	.....
Condition of the covers.....	<input type="checkbox"/>	<input type="checkbox"/>	<input type="checkbox"/>	.....
Condition of hydraulic system and screw fittings...	<input type="checkbox"/>	<input type="checkbox"/>	<input type="checkbox"/>	.....
Level of hydraulic oil .....	<input type="checkbox"/>	<input type="checkbox"/>	<input type="checkbox"/>	.....
Condition hydraulic hoses .....	<input type="checkbox"/>	<input type="checkbox"/>	<input type="checkbox"/>	.....
Condition electrical cables, switches .....	<input type="checkbox"/>	<input type="checkbox"/>	<input type="checkbox"/>	.....
Function test with vehicle.....	<input type="checkbox"/>	<input type="checkbox"/>	<input type="checkbox"/>	.....
Function test wheel free lift with vehicle.....	<input type="checkbox"/>	<input type="checkbox"/>	<input type="checkbox"/>	.....
Condition Polymer supports.....	<input type="checkbox"/>	<input type="checkbox"/>	<input type="checkbox"/>	.....
Condition welding.....	<input type="checkbox"/>	<input type="checkbox"/>	<input type="checkbox"/>	.....
Function CE-Stop + warning signal.....	<input type="checkbox"/>	<input type="checkbox"/>	<input type="checkbox"/>	.....

**( mark here applicable, in case of verification mark in addition to the first mark!)**

Security check carried out:.....

Carried out the company:.....

Name, address of the competent:.....

Result of the Check:

- Initiation not permitted, verification necessary
- Initiation possible, repair failures until.....
- No failings, Initiation possible

.....  
signature of the expert

.....  
signature of the operator

If failures must be repaired:

Failures repaired at: .....  
(Use another form for verification!)

.....  
signature of the operator

**Regular security check**



Filling out and leave in this manual

Serial number: \_\_\_\_\_

kind of check	all right	defect missing	ver-ification	remark
Short Operating instruction.....	<input type="checkbox"/>	<input type="checkbox"/>	<input type="checkbox"/>	.....
Type plate.....	<input type="checkbox"/>	<input type="checkbox"/>	<input type="checkbox"/>	.....
Warning designation, sticker.....	<input type="checkbox"/>	<input type="checkbox"/>	<input type="checkbox"/>	.....
Function button "lifting/lowering".....	<input type="checkbox"/>	<input type="checkbox"/>	<input type="checkbox"/>	.....
Function lever „main lift/wheel free lift“.....	<input type="checkbox"/>	<input type="checkbox"/>	<input type="checkbox"/>	.....
Condition / Function ramp.....	<input type="checkbox"/>	<input type="checkbox"/>	<input type="checkbox"/>	.....
Function play-detector (optional).....	<input type="checkbox"/>	<input type="checkbox"/>	<input type="checkbox"/>	.....
Condition/Function pocket-lamp (optional).....	<input type="checkbox"/>	<input type="checkbox"/>	<input type="checkbox"/>	.....
Security of the bolts.....	<input type="checkbox"/>	<input type="checkbox"/>	<input type="checkbox"/>	.....
Condition bolts and bearings.....	<input type="checkbox"/>	<input type="checkbox"/>	<input type="checkbox"/>	.....
Condition sliding blocks.....	<input type="checkbox"/>	<input type="checkbox"/>	<input type="checkbox"/>	.....
Condition colour.....	<input type="checkbox"/>	<input type="checkbox"/>	<input type="checkbox"/>	.....
Construction (deformation, cracking).....	<input type="checkbox"/>	<input type="checkbox"/>	<input type="checkbox"/>	.....
Condition quality of concrete (cracking).....	<input type="checkbox"/>	<input type="checkbox"/>	<input type="checkbox"/>	.....
Torque moment of the dowels.....	<input type="checkbox"/>	<input type="checkbox"/>	<input type="checkbox"/>	.....
Fixed seat of the screws.....	<input type="checkbox"/>	<input type="checkbox"/>	<input type="checkbox"/>	.....
Condition operating unit.....	<input type="checkbox"/>	<input type="checkbox"/>	<input type="checkbox"/>	.....
Condition piston rod and stripper.....	<input type="checkbox"/>	<input type="checkbox"/>	<input type="checkbox"/>	.....
Condition of the covers.....	<input type="checkbox"/>	<input type="checkbox"/>	<input type="checkbox"/>	.....
Condition of hydraulic system and screw fittings...	<input type="checkbox"/>	<input type="checkbox"/>	<input type="checkbox"/>	.....
Level of hydraulic oil .....	<input type="checkbox"/>	<input type="checkbox"/>	<input type="checkbox"/>	.....
Condition hydraulic hoses .....	<input type="checkbox"/>	<input type="checkbox"/>	<input type="checkbox"/>	.....
Condition electrical cables, switches .....	<input type="checkbox"/>	<input type="checkbox"/>	<input type="checkbox"/>	.....
Function test with vehicle.....	<input type="checkbox"/>	<input type="checkbox"/>	<input type="checkbox"/>	.....
Function test wheel free lift with vehicle.....	<input type="checkbox"/>	<input type="checkbox"/>	<input type="checkbox"/>	.....
Condition Polymer supports.....	<input type="checkbox"/>	<input type="checkbox"/>	<input type="checkbox"/>	.....
Condition welding.....	<input type="checkbox"/>	<input type="checkbox"/>	<input type="checkbox"/>	.....
Function CE-Stop + warning signal.....	<input type="checkbox"/>	<input type="checkbox"/>	<input type="checkbox"/>	.....

**( mark here applicable, in case of verification mark in addition to the first mark!)**

Security check carried out:.....

Carried out the company:.....

Name, address of the competent:.....

Result of the Check:

- Initiation not permitted, verification necessary
- Initiation possible, repair failures until.....
- No failings, Initiation possible

.....  
signature of the expert

.....  
signature of the operator

If failures must be repaired:

Failures repaired at: .....  
(Use another form for verification!)

.....  
signature of the operator

**Regular security check**



Filling out and leave in this manual

Serial number: \_\_\_\_\_

kind of check	all right	defect missing	verification	remark
Short Operating instruction.....	<input type="checkbox"/>	<input type="checkbox"/>	<input type="checkbox"/>	.....
Type plate.....	<input type="checkbox"/>	<input type="checkbox"/>	<input type="checkbox"/>	.....
Warning designation, sticker.....	<input type="checkbox"/>	<input type="checkbox"/>	<input type="checkbox"/>	.....
Function button "lifting/lowering".....	<input type="checkbox"/>	<input type="checkbox"/>	<input type="checkbox"/>	.....
Function lever „main lift/wheel free lift“.....	<input type="checkbox"/>	<input type="checkbox"/>	<input type="checkbox"/>	.....
Condition / Function ramp.....	<input type="checkbox"/>	<input type="checkbox"/>	<input type="checkbox"/>	.....
Function play-detector (optional).....	<input type="checkbox"/>	<input type="checkbox"/>	<input type="checkbox"/>	.....
Condition/Function pocket-lamp (optional).....	<input type="checkbox"/>	<input type="checkbox"/>	<input type="checkbox"/>	.....
Security of the bolts.....	<input type="checkbox"/>	<input type="checkbox"/>	<input type="checkbox"/>	.....
Condition bolts and bearings.....	<input type="checkbox"/>	<input type="checkbox"/>	<input type="checkbox"/>	.....
Condition sliding blocks.....	<input type="checkbox"/>	<input type="checkbox"/>	<input type="checkbox"/>	.....
Condition colour.....	<input type="checkbox"/>	<input type="checkbox"/>	<input type="checkbox"/>	.....
Construction (deformation, cracking).....	<input type="checkbox"/>	<input type="checkbox"/>	<input type="checkbox"/>	.....
Condition quality of concrete (cracking).....	<input type="checkbox"/>	<input type="checkbox"/>	<input type="checkbox"/>	.....
Torque moment of the dowels.....	<input type="checkbox"/>	<input type="checkbox"/>	<input type="checkbox"/>	.....
Fixed seat of the screws.....	<input type="checkbox"/>	<input type="checkbox"/>	<input type="checkbox"/>	.....
Condition operating unit.....	<input type="checkbox"/>	<input type="checkbox"/>	<input type="checkbox"/>	.....
Condition piston rod and stripper.....	<input type="checkbox"/>	<input type="checkbox"/>	<input type="checkbox"/>	.....
Condition of the covers.....	<input type="checkbox"/>	<input type="checkbox"/>	<input type="checkbox"/>	.....
Condition of hydraulic system and screw fittings...	<input type="checkbox"/>	<input type="checkbox"/>	<input type="checkbox"/>	.....
Level of hydraulic oil .....	<input type="checkbox"/>	<input type="checkbox"/>	<input type="checkbox"/>	.....
Condition hydraulic hoses .....	<input type="checkbox"/>	<input type="checkbox"/>	<input type="checkbox"/>	.....
Condition electrical cables, switches .....	<input type="checkbox"/>	<input type="checkbox"/>	<input type="checkbox"/>	.....
Function test with vehicle.....	<input type="checkbox"/>	<input type="checkbox"/>	<input type="checkbox"/>	.....
Function test wheel free lift with vehicle.....	<input type="checkbox"/>	<input type="checkbox"/>	<input type="checkbox"/>	.....
Condition Polymer supports.....	<input type="checkbox"/>	<input type="checkbox"/>	<input type="checkbox"/>	.....
Condition welding.....	<input type="checkbox"/>	<input type="checkbox"/>	<input type="checkbox"/>	.....
Function CE-Stop + warning signal.....	<input type="checkbox"/>	<input type="checkbox"/>	<input type="checkbox"/>	.....

**( mark here applicable, in case of verification mark in addition to the first mark!)**

Security check carried out:.....

Carried out the company:.....

Name, address of the competent:.....

Result of the Check:

- Initiation not permitted, verification necessary
- Initiation possible, repair failures until.....
- No failings, Initiation possible

.....  
signature of the expert

.....  
signature of the operator

If failures must be repaired:

Failures repaired at: .....  
(Use another form for verification!)

.....  
signature of the operator

**Regular security check**



Filling out and leave in this manual

Serial number: \_\_\_\_\_

kind of check	all right	defect missing	verification	remark
Short Operating instruction.....	<input type="checkbox"/>	<input type="checkbox"/>	<input type="checkbox"/>	.....
Type plate.....	<input type="checkbox"/>	<input type="checkbox"/>	<input type="checkbox"/>	.....
Warning designation, sticker.....	<input type="checkbox"/>	<input type="checkbox"/>	<input type="checkbox"/>	.....
Function button "lifting/lowering".....	<input type="checkbox"/>	<input type="checkbox"/>	<input type="checkbox"/>	.....
Function lever „main lift/wheel free lift“.....	<input type="checkbox"/>	<input type="checkbox"/>	<input type="checkbox"/>	.....
Condition / Function ramp.....	<input type="checkbox"/>	<input type="checkbox"/>	<input type="checkbox"/>	.....
Function play-detector (optional).....	<input type="checkbox"/>	<input type="checkbox"/>	<input type="checkbox"/>	.....
Condition/Function pocket-lamp (optional).....	<input type="checkbox"/>	<input type="checkbox"/>	<input type="checkbox"/>	.....
Security of the bolts.....	<input type="checkbox"/>	<input type="checkbox"/>	<input type="checkbox"/>	.....
Condition bolts and bearings.....	<input type="checkbox"/>	<input type="checkbox"/>	<input type="checkbox"/>	.....
Condition sliding blocks.....	<input type="checkbox"/>	<input type="checkbox"/>	<input type="checkbox"/>	.....
Condition colour.....	<input type="checkbox"/>	<input type="checkbox"/>	<input type="checkbox"/>	.....
Construction (deformation, cracking).....	<input type="checkbox"/>	<input type="checkbox"/>	<input type="checkbox"/>	.....
Condition quality of concrete (cracking).....	<input type="checkbox"/>	<input type="checkbox"/>	<input type="checkbox"/>	.....
Torque moment of the dowels.....	<input type="checkbox"/>	<input type="checkbox"/>	<input type="checkbox"/>	.....
Fixed seat of the screws.....	<input type="checkbox"/>	<input type="checkbox"/>	<input type="checkbox"/>	.....
Condition operating unit.....	<input type="checkbox"/>	<input type="checkbox"/>	<input type="checkbox"/>	.....
Condition piston rod and stripper.....	<input type="checkbox"/>	<input type="checkbox"/>	<input type="checkbox"/>	.....
Condition of the covers.....	<input type="checkbox"/>	<input type="checkbox"/>	<input type="checkbox"/>	.....
Condition of hydraulic system and screw fittings...	<input type="checkbox"/>	<input type="checkbox"/>	<input type="checkbox"/>	.....
Level of hydraulic oil .....	<input type="checkbox"/>	<input type="checkbox"/>	<input type="checkbox"/>	.....
Condition hydraulic hoses .....	<input type="checkbox"/>	<input type="checkbox"/>	<input type="checkbox"/>	.....
Condition electrical cables, switches .....	<input type="checkbox"/>	<input type="checkbox"/>	<input type="checkbox"/>	.....
Function test with vehicle.....	<input type="checkbox"/>	<input type="checkbox"/>	<input type="checkbox"/>	.....
Function test wheel free lift with vehicle.....	<input type="checkbox"/>	<input type="checkbox"/>	<input type="checkbox"/>	.....
Condition Polymer supports.....	<input type="checkbox"/>	<input type="checkbox"/>	<input type="checkbox"/>	.....
Condition welding.....	<input type="checkbox"/>	<input type="checkbox"/>	<input type="checkbox"/>	.....
Function CE-Stop + warning signal.....	<input type="checkbox"/>	<input type="checkbox"/>	<input type="checkbox"/>	.....

**( mark here applicable, in case of verification mark in addition to the first mark!)**

Security check carried out:.....

Carried out the company:.....

Name, address of the competent:.....

Result of the Check:

- Initiation not permitted, verification necessary
- Initiation possible, repair failures until.....
- No failings, Initiation possible

.....  
signature of the expert

.....  
signature of the operator

If failures must be repaired:

Failures repaired at: .....  
(Use another form for verification!)

.....  
signature of the operator

**Regular security check**



Filling out and leave in this manual

Serial number: \_\_\_\_\_

kind of check	all right	defect missing	ver-ification	remark
Short Operating instruction.....	<input type="checkbox"/>	<input type="checkbox"/>	<input type="checkbox"/>	.....
Type plate.....	<input type="checkbox"/>	<input type="checkbox"/>	<input type="checkbox"/>	.....
Warning designation, sticker.....	<input type="checkbox"/>	<input type="checkbox"/>	<input type="checkbox"/>	.....
Function button "lifting/lowering".....	<input type="checkbox"/>	<input type="checkbox"/>	<input type="checkbox"/>	.....
Function lever „main lift/wheel free lift“.....	<input type="checkbox"/>	<input type="checkbox"/>	<input type="checkbox"/>	.....
Condition / Function ramp.....	<input type="checkbox"/>	<input type="checkbox"/>	<input type="checkbox"/>	.....
Function play-detector (optional).....	<input type="checkbox"/>	<input type="checkbox"/>	<input type="checkbox"/>	.....
Condition/Function pocket-lamp (optional).....	<input type="checkbox"/>	<input type="checkbox"/>	<input type="checkbox"/>	.....
Security of the bolts.....	<input type="checkbox"/>	<input type="checkbox"/>	<input type="checkbox"/>	.....
Condition bolts and bearings.....	<input type="checkbox"/>	<input type="checkbox"/>	<input type="checkbox"/>	.....
Condition sliding blocks.....	<input type="checkbox"/>	<input type="checkbox"/>	<input type="checkbox"/>	.....
Condition colour.....	<input type="checkbox"/>	<input type="checkbox"/>	<input type="checkbox"/>	.....
Construction (deformation, cracking).....	<input type="checkbox"/>	<input type="checkbox"/>	<input type="checkbox"/>	.....
Condition quality of concrete (cracking).....	<input type="checkbox"/>	<input type="checkbox"/>	<input type="checkbox"/>	.....
Torque moment of the dowels.....	<input type="checkbox"/>	<input type="checkbox"/>	<input type="checkbox"/>	.....
Fixed seat of the screws.....	<input type="checkbox"/>	<input type="checkbox"/>	<input type="checkbox"/>	.....
Condition operating unit.....	<input type="checkbox"/>	<input type="checkbox"/>	<input type="checkbox"/>	.....
Condition piston rod and stripper.....	<input type="checkbox"/>	<input type="checkbox"/>	<input type="checkbox"/>	.....
Condition of the covers.....	<input type="checkbox"/>	<input type="checkbox"/>	<input type="checkbox"/>	.....
Condition of hydraulic system and screw fittings...	<input type="checkbox"/>	<input type="checkbox"/>	<input type="checkbox"/>	.....
Level of hydraulic oil .....	<input type="checkbox"/>	<input type="checkbox"/>	<input type="checkbox"/>	.....
Condition hydraulic hoses .....	<input type="checkbox"/>	<input type="checkbox"/>	<input type="checkbox"/>	.....
Condition electrical cables, switches .....	<input type="checkbox"/>	<input type="checkbox"/>	<input type="checkbox"/>	.....
Function test with vehicle.....	<input type="checkbox"/>	<input type="checkbox"/>	<input type="checkbox"/>	.....
Function test wheel free lift with vehicle.....	<input type="checkbox"/>	<input type="checkbox"/>	<input type="checkbox"/>	.....
Condition Polymer supports.....	<input type="checkbox"/>	<input type="checkbox"/>	<input type="checkbox"/>	.....
Condition welding.....	<input type="checkbox"/>	<input type="checkbox"/>	<input type="checkbox"/>	.....
Function CE-Stop + warning signal.....	<input type="checkbox"/>	<input type="checkbox"/>	<input type="checkbox"/>	.....

**( mark here applicable, in case of verification mark in addition to the first mark!)**

Security check carried out:.....

Carried out the company:.....

Name, address of the competent:.....

Result of the Check:

- Initiation not permitted, verification necessary
- Initiation possible, repair failures until.....
- No failings, Initiation possible

.....  
signature of the expert

.....  
signature of the operator

If failures must be repaired:

Failures repaired at: .....  
(Use another form for verification!)

.....  
signature of the operator

**Regular security check**



Filling out and leave in this manual

Serial number: \_\_\_\_\_

kind of check	all right	defect missing	verification	remark
Short Operating instruction.....	<input type="checkbox"/>	<input type="checkbox"/>	<input type="checkbox"/>	.....
Type plate.....	<input type="checkbox"/>	<input type="checkbox"/>	<input type="checkbox"/>	.....
Warning designation, sticker.....	<input type="checkbox"/>	<input type="checkbox"/>	<input type="checkbox"/>	.....
Function button "lifting/lowering".....	<input type="checkbox"/>	<input type="checkbox"/>	<input type="checkbox"/>	.....
Function lever „main lift/wheel free lift“.....	<input type="checkbox"/>	<input type="checkbox"/>	<input type="checkbox"/>	.....
Condition / Function ramp.....	<input type="checkbox"/>	<input type="checkbox"/>	<input type="checkbox"/>	.....
Function play-detector (optional).....	<input type="checkbox"/>	<input type="checkbox"/>	<input type="checkbox"/>	.....
Condition/Function pocket-lamp (optional).....	<input type="checkbox"/>	<input type="checkbox"/>	<input type="checkbox"/>	.....
Security of the bolts.....	<input type="checkbox"/>	<input type="checkbox"/>	<input type="checkbox"/>	.....
Condition bolts and bearings.....	<input type="checkbox"/>	<input type="checkbox"/>	<input type="checkbox"/>	.....
Condition sliding blocks.....	<input type="checkbox"/>	<input type="checkbox"/>	<input type="checkbox"/>	.....
Condition colour.....	<input type="checkbox"/>	<input type="checkbox"/>	<input type="checkbox"/>	.....
Construction (deformation, cracking).....	<input type="checkbox"/>	<input type="checkbox"/>	<input type="checkbox"/>	.....
Condition quality of concrete (cracking).....	<input type="checkbox"/>	<input type="checkbox"/>	<input type="checkbox"/>	.....
Torque moment of the dowels.....	<input type="checkbox"/>	<input type="checkbox"/>	<input type="checkbox"/>	.....
Fixed seat of the screws.....	<input type="checkbox"/>	<input type="checkbox"/>	<input type="checkbox"/>	.....
Condition operating unit.....	<input type="checkbox"/>	<input type="checkbox"/>	<input type="checkbox"/>	.....
Condition piston rod and stripper.....	<input type="checkbox"/>	<input type="checkbox"/>	<input type="checkbox"/>	.....
Condition of the covers.....	<input type="checkbox"/>	<input type="checkbox"/>	<input type="checkbox"/>	.....
Condition of hydraulic system and screw fittings...	<input type="checkbox"/>	<input type="checkbox"/>	<input type="checkbox"/>	.....
Level of hydraulic oil .....	<input type="checkbox"/>	<input type="checkbox"/>	<input type="checkbox"/>	.....
Condition hydraulic hoses .....	<input type="checkbox"/>	<input type="checkbox"/>	<input type="checkbox"/>	.....
Condition electrical cables, switches .....	<input type="checkbox"/>	<input type="checkbox"/>	<input type="checkbox"/>	.....
Function test with vehicle.....	<input type="checkbox"/>	<input type="checkbox"/>	<input type="checkbox"/>	.....
Function test wheel free lift with vehicle.....	<input type="checkbox"/>	<input type="checkbox"/>	<input type="checkbox"/>	.....
Condition Polymer supports.....	<input type="checkbox"/>	<input type="checkbox"/>	<input type="checkbox"/>	.....
Condition welding.....	<input type="checkbox"/>	<input type="checkbox"/>	<input type="checkbox"/>	.....
Function CE-Stop + warning signal.....	<input type="checkbox"/>	<input type="checkbox"/>	<input type="checkbox"/>	.....

**( mark here applicable, in case of verification mark in addition to the first mark!)**

Security check carried out:.....

Carried out the company:.....

Name, address of the competent:.....

Result of the Check:

- Initiation not permitted, verification necessary
- Initiation possible, repair failures until.....
- No failings, Initiation possible

.....  
signature of the expert

.....  
signature of the operator

If failures must be repaired:

Failures repaired at: .....  
(Use another form for verification!)

.....  
signature of the operator



**Regular security check**



Filling out and leave in this manual

Serial number: \_\_\_\_\_

kind of check	all right	defect missing	verification	remark
Short Operating instruction.....	<input type="checkbox"/>	<input type="checkbox"/>	<input type="checkbox"/>	.....
Type plate.....	<input type="checkbox"/>	<input type="checkbox"/>	<input type="checkbox"/>	.....
Warning designation, sticker.....	<input type="checkbox"/>	<input type="checkbox"/>	<input type="checkbox"/>	.....
Function button "lifting/lowering".....	<input type="checkbox"/>	<input type="checkbox"/>	<input type="checkbox"/>	.....
Function lever „main lift/wheel free lift“.....	<input type="checkbox"/>	<input type="checkbox"/>	<input type="checkbox"/>	.....
Condition / Function ramp.....	<input type="checkbox"/>	<input type="checkbox"/>	<input type="checkbox"/>	.....
Function play-detector (optional).....	<input type="checkbox"/>	<input type="checkbox"/>	<input type="checkbox"/>	.....
Condition/Function pocket-lamp (optional).....	<input type="checkbox"/>	<input type="checkbox"/>	<input type="checkbox"/>	.....
Security of the bolts.....	<input type="checkbox"/>	<input type="checkbox"/>	<input type="checkbox"/>	.....
Condition bolts and bearings.....	<input type="checkbox"/>	<input type="checkbox"/>	<input type="checkbox"/>	.....
Condition sliding blocks.....	<input type="checkbox"/>	<input type="checkbox"/>	<input type="checkbox"/>	.....
Condition colour.....	<input type="checkbox"/>	<input type="checkbox"/>	<input type="checkbox"/>	.....
Construction (deformation, cracking).....	<input type="checkbox"/>	<input type="checkbox"/>	<input type="checkbox"/>	.....
Condition quality of concrete (cracking).....	<input type="checkbox"/>	<input type="checkbox"/>	<input type="checkbox"/>	.....
Torque moment of the dowels.....	<input type="checkbox"/>	<input type="checkbox"/>	<input type="checkbox"/>	.....
Fixed seat of the screws.....	<input type="checkbox"/>	<input type="checkbox"/>	<input type="checkbox"/>	.....
Condition operating unit.....	<input type="checkbox"/>	<input type="checkbox"/>	<input type="checkbox"/>	.....
Condition piston rod and stripper.....	<input type="checkbox"/>	<input type="checkbox"/>	<input type="checkbox"/>	.....
Condition of the covers.....	<input type="checkbox"/>	<input type="checkbox"/>	<input type="checkbox"/>	.....
Condition of hydraulic system and screw fittings...	<input type="checkbox"/>	<input type="checkbox"/>	<input type="checkbox"/>	.....
Level of hydraulic oil .....	<input type="checkbox"/>	<input type="checkbox"/>	<input type="checkbox"/>	.....
Condition hydraulic hoses .....	<input type="checkbox"/>	<input type="checkbox"/>	<input type="checkbox"/>	.....
Condition electrical cables, switches .....	<input type="checkbox"/>	<input type="checkbox"/>	<input type="checkbox"/>	.....
Function test with vehicle.....	<input type="checkbox"/>	<input type="checkbox"/>	<input type="checkbox"/>	.....
Function test wheel free lift with vehicle.....	<input type="checkbox"/>	<input type="checkbox"/>	<input type="checkbox"/>	.....
Condition Polymer supports.....	<input type="checkbox"/>	<input type="checkbox"/>	<input type="checkbox"/>	.....
Condition welding.....	<input type="checkbox"/>	<input type="checkbox"/>	<input type="checkbox"/>	.....
Function CE-Stop + warning signal.....	<input type="checkbox"/>	<input type="checkbox"/>	<input type="checkbox"/>	.....

**( mark here applicable, in case of verification mark in addition to the first mark!)**

Security check carried out:.....

Carried out the company:.....

Name, address of the competent:.....

Result of the Check:

- Initiation not permitted, verification necessary
- Initiation possible, repair failures until.....
- No failings, Initiation possible

.....  
signature of the expert

.....  
signature of the operator

If failures must be repaired:

Failures repaired at: .....  
(Use another form for verification!)

.....  
signature of the operator

**Regular security check**



Filling out and leave in this manual

Serial number: \_\_\_\_\_

kind of check	all right	defect missing	verification	remark
Short Operating instruction.....	<input type="checkbox"/>	<input type="checkbox"/>	<input type="checkbox"/>	.....
Type plate.....	<input type="checkbox"/>	<input type="checkbox"/>	<input type="checkbox"/>	.....
Warning designation, sticker.....	<input type="checkbox"/>	<input type="checkbox"/>	<input type="checkbox"/>	.....
Function button "lifting/lowering".....	<input type="checkbox"/>	<input type="checkbox"/>	<input type="checkbox"/>	.....
Function lever „main lift/wheel free lift“.....	<input type="checkbox"/>	<input type="checkbox"/>	<input type="checkbox"/>	.....
Condition / Function ramp.....	<input type="checkbox"/>	<input type="checkbox"/>	<input type="checkbox"/>	.....
Function play-detector (optional).....	<input type="checkbox"/>	<input type="checkbox"/>	<input type="checkbox"/>	.....
Condition/Function pocket-lamp (optional).....	<input type="checkbox"/>	<input type="checkbox"/>	<input type="checkbox"/>	.....
Security of the bolts.....	<input type="checkbox"/>	<input type="checkbox"/>	<input type="checkbox"/>	.....
Condition bolts and bearings.....	<input type="checkbox"/>	<input type="checkbox"/>	<input type="checkbox"/>	.....
Condition sliding blocks.....	<input type="checkbox"/>	<input type="checkbox"/>	<input type="checkbox"/>	.....
Condition colour.....	<input type="checkbox"/>	<input type="checkbox"/>	<input type="checkbox"/>	.....
Construction (deformation, cracking).....	<input type="checkbox"/>	<input type="checkbox"/>	<input type="checkbox"/>	.....
Condition quality of concrete (cracking).....	<input type="checkbox"/>	<input type="checkbox"/>	<input type="checkbox"/>	.....
Torque moment of the dowels.....	<input type="checkbox"/>	<input type="checkbox"/>	<input type="checkbox"/>	.....
Fixed seat of the screws.....	<input type="checkbox"/>	<input type="checkbox"/>	<input type="checkbox"/>	.....
Condition operating unit.....	<input type="checkbox"/>	<input type="checkbox"/>	<input type="checkbox"/>	.....
Condition piston rod and stripper.....	<input type="checkbox"/>	<input type="checkbox"/>	<input type="checkbox"/>	.....
Condition of the covers.....	<input type="checkbox"/>	<input type="checkbox"/>	<input type="checkbox"/>	.....
Condition of hydraulic system and screw fittings.....	<input type="checkbox"/>	<input type="checkbox"/>	<input type="checkbox"/>	.....
Level of hydraulic oil .....	<input type="checkbox"/>	<input type="checkbox"/>	<input type="checkbox"/>	.....
Condition hydraulic hoses .....	<input type="checkbox"/>	<input type="checkbox"/>	<input type="checkbox"/>	.....
Condition electrical cables, switches .....	<input type="checkbox"/>	<input type="checkbox"/>	<input type="checkbox"/>	.....
Function test with vehicle.....	<input type="checkbox"/>	<input type="checkbox"/>	<input type="checkbox"/>	.....
Function test wheel free lift with vehicle.....	<input type="checkbox"/>	<input type="checkbox"/>	<input type="checkbox"/>	.....
Condition Polymer supports.....	<input type="checkbox"/>	<input type="checkbox"/>	<input type="checkbox"/>	.....
Condition welding.....	<input type="checkbox"/>	<input type="checkbox"/>	<input type="checkbox"/>	.....
Function CE-Stop + warning signal.....	<input type="checkbox"/>	<input type="checkbox"/>	<input type="checkbox"/>	.....

**( mark here applicable, in case of verification mark in addition to the first mark!)**

Security check carried out:.....

Carried out the company:.....

Name, address of the competent:.....

Result of the Check:

- Initiation not permitted, verification necessary
- Initiation possible, repair failures until.....
- No failings, Initiation possible

.....  
signature of the expert

.....  
signature of the operator

If failures must be repaired:

Failures repaired at: .....  
(Use another form for verification!)

.....  
signature of the operator

**Regular security check**



Filling out and leave in this manual

Serial number: \_\_\_\_\_

kind of check	all right	defect missing	verification	remark
Short Operating instruction.....	<input type="checkbox"/>	<input type="checkbox"/>	<input type="checkbox"/>	.....
Type plate.....	<input type="checkbox"/>	<input type="checkbox"/>	<input type="checkbox"/>	.....
Warning designation, sticker.....	<input type="checkbox"/>	<input type="checkbox"/>	<input type="checkbox"/>	.....
Function button "lifting/lowering".....	<input type="checkbox"/>	<input type="checkbox"/>	<input type="checkbox"/>	.....
Function lever „main lift/wheel free lift“.....	<input type="checkbox"/>	<input type="checkbox"/>	<input type="checkbox"/>	.....
Condition / Function ramp.....	<input type="checkbox"/>	<input type="checkbox"/>	<input type="checkbox"/>	.....
Function play-detector (optional).....	<input type="checkbox"/>	<input type="checkbox"/>	<input type="checkbox"/>	.....
Condition/Function pocket-lamp (optional).....	<input type="checkbox"/>	<input type="checkbox"/>	<input type="checkbox"/>	.....
Security of the bolts.....	<input type="checkbox"/>	<input type="checkbox"/>	<input type="checkbox"/>	.....
Condition bolts and bearings.....	<input type="checkbox"/>	<input type="checkbox"/>	<input type="checkbox"/>	.....
Condition sliding blocks.....	<input type="checkbox"/>	<input type="checkbox"/>	<input type="checkbox"/>	.....
Condition colour.....	<input type="checkbox"/>	<input type="checkbox"/>	<input type="checkbox"/>	.....
Construction (deformation, cracking).....	<input type="checkbox"/>	<input type="checkbox"/>	<input type="checkbox"/>	.....
Condition quality of concrete (cracking).....	<input type="checkbox"/>	<input type="checkbox"/>	<input type="checkbox"/>	.....
Torque moment of the dowels.....	<input type="checkbox"/>	<input type="checkbox"/>	<input type="checkbox"/>	.....
Fixed seat of the screws.....	<input type="checkbox"/>	<input type="checkbox"/>	<input type="checkbox"/>	.....
Condition operating unit.....	<input type="checkbox"/>	<input type="checkbox"/>	<input type="checkbox"/>	.....
Condition piston rod and stripper.....	<input type="checkbox"/>	<input type="checkbox"/>	<input type="checkbox"/>	.....
Condition of the covers.....	<input type="checkbox"/>	<input type="checkbox"/>	<input type="checkbox"/>	.....
Condition of hydraulic system and screw fittings...	<input type="checkbox"/>	<input type="checkbox"/>	<input type="checkbox"/>	.....
Level of hydraulic oil .....	<input type="checkbox"/>	<input type="checkbox"/>	<input type="checkbox"/>	.....
Condition hydraulic hoses .....	<input type="checkbox"/>	<input type="checkbox"/>	<input type="checkbox"/>	.....
Condition electrical cables, switches .....	<input type="checkbox"/>	<input type="checkbox"/>	<input type="checkbox"/>	.....
Function test with vehicle.....	<input type="checkbox"/>	<input type="checkbox"/>	<input type="checkbox"/>	.....
Function test wheel free lift with vehicle.....	<input type="checkbox"/>	<input type="checkbox"/>	<input type="checkbox"/>	.....
Condition Polymer supports.....	<input type="checkbox"/>	<input type="checkbox"/>	<input type="checkbox"/>	.....
Condition welding.....	<input type="checkbox"/>	<input type="checkbox"/>	<input type="checkbox"/>	.....
Function CE-Stop + warning signal.....	<input type="checkbox"/>	<input type="checkbox"/>	<input type="checkbox"/>	.....

**( mark here applicable, in case of verification mark in addition to the first mark!)**

Security check carried out:.....

Carried out the company:.....

Name, address of the competent:.....

Result of the Check:

- Initiation not permitted, verification necessary
- Initiation possible, repair failures until.....
- No failings, Initiation possible

.....  
signature of the expert

.....  
signature of the operator

If failures must be repaired:

Failures repaired at: .....  
(Use another form for verification!)

.....  
signature of the operator

**Regular security check**



Filling out and leave in this manual

Serial number: \_\_\_\_\_

kind of check	all right	defect missing	verification	remark
Short Operating instruction.....	<input type="checkbox"/>	<input type="checkbox"/>	<input type="checkbox"/>	.....
Type plate.....	<input type="checkbox"/>	<input type="checkbox"/>	<input type="checkbox"/>	.....
Warning designation, sticker.....	<input type="checkbox"/>	<input type="checkbox"/>	<input type="checkbox"/>	.....
Function button "lifting/lowering".....	<input type="checkbox"/>	<input type="checkbox"/>	<input type="checkbox"/>	.....
Function lever „main lift/wheel free lift“.....	<input type="checkbox"/>	<input type="checkbox"/>	<input type="checkbox"/>	.....
Condition / Function ramp.....	<input type="checkbox"/>	<input type="checkbox"/>	<input type="checkbox"/>	.....
Function play-detector (optional).....	<input type="checkbox"/>	<input type="checkbox"/>	<input type="checkbox"/>	.....
Condition/Function pocket-lamp (optional).....	<input type="checkbox"/>	<input type="checkbox"/>	<input type="checkbox"/>	.....
Security of the bolts.....	<input type="checkbox"/>	<input type="checkbox"/>	<input type="checkbox"/>	.....
Condition bolts and bearings.....	<input type="checkbox"/>	<input type="checkbox"/>	<input type="checkbox"/>	.....
Condition sliding blocks.....	<input type="checkbox"/>	<input type="checkbox"/>	<input type="checkbox"/>	.....
Condition colour.....	<input type="checkbox"/>	<input type="checkbox"/>	<input type="checkbox"/>	.....
Construction (deformation, cracking).....	<input type="checkbox"/>	<input type="checkbox"/>	<input type="checkbox"/>	.....
Condition quality of concrete (cracking).....	<input type="checkbox"/>	<input type="checkbox"/>	<input type="checkbox"/>	.....
Torque moment of the dowels.....	<input type="checkbox"/>	<input type="checkbox"/>	<input type="checkbox"/>	.....
Fixed seat of the screws.....	<input type="checkbox"/>	<input type="checkbox"/>	<input type="checkbox"/>	.....
Condition operating unit.....	<input type="checkbox"/>	<input type="checkbox"/>	<input type="checkbox"/>	.....
Condition piston rod and stripper.....	<input type="checkbox"/>	<input type="checkbox"/>	<input type="checkbox"/>	.....
Condition of the covers.....	<input type="checkbox"/>	<input type="checkbox"/>	<input type="checkbox"/>	.....
Condition of hydraulic system and screw fittings...	<input type="checkbox"/>	<input type="checkbox"/>	<input type="checkbox"/>	.....
Level of hydraulic oil .....	<input type="checkbox"/>	<input type="checkbox"/>	<input type="checkbox"/>	.....
Condition hydraulic hoses .....	<input type="checkbox"/>	<input type="checkbox"/>	<input type="checkbox"/>	.....
Condition electrical cables, switches .....	<input type="checkbox"/>	<input type="checkbox"/>	<input type="checkbox"/>	.....
Function test with vehicle.....	<input type="checkbox"/>	<input type="checkbox"/>	<input type="checkbox"/>	.....
Function test wheel free lift with vehicle.....	<input type="checkbox"/>	<input type="checkbox"/>	<input type="checkbox"/>	.....
Condition Polymer supports.....	<input type="checkbox"/>	<input type="checkbox"/>	<input type="checkbox"/>	.....
Condition welding.....	<input type="checkbox"/>	<input type="checkbox"/>	<input type="checkbox"/>	.....
Function CE-Stop + warning signal.....	<input type="checkbox"/>	<input type="checkbox"/>	<input type="checkbox"/>	.....

**( mark here applicable, in case of verification mark in addition to the first mark!)**

Security check carried out:.....

Carried out the company:.....

Name, address of the competent:.....

Result of the Check:

- Initiation not permitted, verification necessary
- Initiation possible, repair failures until.....
- No failings, Initiation possible

.....  
signature of the expert

.....  
signature of the operator

If failures must be repaired:

Failures repaired at: .....  
(Use another form for verification!)

.....  
signature of the operator

**Regular security check**



Filling out and leave in this manual

Serial number: \_\_\_\_\_

kind of check	all right	defect missing	verification	remark
Short Operating instruction.....	<input type="checkbox"/>	<input type="checkbox"/>	<input type="checkbox"/>	.....
Type plate.....	<input type="checkbox"/>	<input type="checkbox"/>	<input type="checkbox"/>	.....
Warning designation, sticker.....	<input type="checkbox"/>	<input type="checkbox"/>	<input type="checkbox"/>	.....
Function button "lifting/lowering".....	<input type="checkbox"/>	<input type="checkbox"/>	<input type="checkbox"/>	.....
Function lever „main lift/wheel free lift“.....	<input type="checkbox"/>	<input type="checkbox"/>	<input type="checkbox"/>	.....
Condition / Function ramp.....	<input type="checkbox"/>	<input type="checkbox"/>	<input type="checkbox"/>	.....
Function play-detector (optional).....	<input type="checkbox"/>	<input type="checkbox"/>	<input type="checkbox"/>	.....
Condition/Function pocket-lamp (optional).....	<input type="checkbox"/>	<input type="checkbox"/>	<input type="checkbox"/>	.....
Security of the bolts.....	<input type="checkbox"/>	<input type="checkbox"/>	<input type="checkbox"/>	.....
Condition bolts and bearings.....	<input type="checkbox"/>	<input type="checkbox"/>	<input type="checkbox"/>	.....
Condition sliding blocks.....	<input type="checkbox"/>	<input type="checkbox"/>	<input type="checkbox"/>	.....
Condition colour.....	<input type="checkbox"/>	<input type="checkbox"/>	<input type="checkbox"/>	.....
Construction (deformation, cracking).....	<input type="checkbox"/>	<input type="checkbox"/>	<input type="checkbox"/>	.....
Condition quality of concrete (cracking).....	<input type="checkbox"/>	<input type="checkbox"/>	<input type="checkbox"/>	.....
Torque moment of the dowels.....	<input type="checkbox"/>	<input type="checkbox"/>	<input type="checkbox"/>	.....
Fixed seat of the screws.....	<input type="checkbox"/>	<input type="checkbox"/>	<input type="checkbox"/>	.....
Condition operating unit.....	<input type="checkbox"/>	<input type="checkbox"/>	<input type="checkbox"/>	.....
Condition piston rod and stripper.....	<input type="checkbox"/>	<input type="checkbox"/>	<input type="checkbox"/>	.....
Condition of the covers.....	<input type="checkbox"/>	<input type="checkbox"/>	<input type="checkbox"/>	.....
Condition of hydraulic system and screw fittings.....	<input type="checkbox"/>	<input type="checkbox"/>	<input type="checkbox"/>	.....
Level of hydraulic oil .....	<input type="checkbox"/>	<input type="checkbox"/>	<input type="checkbox"/>	.....
Condition hydraulic hoses .....	<input type="checkbox"/>	<input type="checkbox"/>	<input type="checkbox"/>	.....
Condition electrical cables, switches .....	<input type="checkbox"/>	<input type="checkbox"/>	<input type="checkbox"/>	.....
Function test with vehicle.....	<input type="checkbox"/>	<input type="checkbox"/>	<input type="checkbox"/>	.....
Function test wheel free lift with vehicle.....	<input type="checkbox"/>	<input type="checkbox"/>	<input type="checkbox"/>	.....
Condition Polymer supports.....	<input type="checkbox"/>	<input type="checkbox"/>	<input type="checkbox"/>	.....
Condition welding.....	<input type="checkbox"/>	<input type="checkbox"/>	<input type="checkbox"/>	.....
Function CE-Stop + warning signal.....	<input type="checkbox"/>	<input type="checkbox"/>	<input type="checkbox"/>	.....

**( mark here applicable, in case of verification mark in addition to the first mark!)**

Security check carried out:.....

Carried out the company:.....

Name, address of the competent:.....

Result of the Check:

- Initiation not permitted, verification necessary
- Initiation possible, repair failures until.....
- No failings, Initiation possible

.....  
signature of the expert

.....  
signature of the operator

If failures must be repaired:

Failures repaired at: .....  
(Use another form for verification!)

.....  
signature of the operator

**Regular security check**



Filling out and leave in this manual

Serial number: \_\_\_\_\_

kind of check	all right	defect missing	verification	remark
Short Operating instruction.....	<input type="checkbox"/>	<input type="checkbox"/>	<input type="checkbox"/>	.....
Type plate.....	<input type="checkbox"/>	<input type="checkbox"/>	<input type="checkbox"/>	.....
Warning designation, sticker.....	<input type="checkbox"/>	<input type="checkbox"/>	<input type="checkbox"/>	.....
Function button "lifting/lowering".....	<input type="checkbox"/>	<input type="checkbox"/>	<input type="checkbox"/>	.....
Function lever „main lift/wheel free lift“.....	<input type="checkbox"/>	<input type="checkbox"/>	<input type="checkbox"/>	.....
Condition / Function ramp.....	<input type="checkbox"/>	<input type="checkbox"/>	<input type="checkbox"/>	.....
Function play-detector (optional).....	<input type="checkbox"/>	<input type="checkbox"/>	<input type="checkbox"/>	.....
Condition/Function pocket-lamp (optional).....	<input type="checkbox"/>	<input type="checkbox"/>	<input type="checkbox"/>	.....
Security of the bolts.....	<input type="checkbox"/>	<input type="checkbox"/>	<input type="checkbox"/>	.....
Condition bolts and bearings.....	<input type="checkbox"/>	<input type="checkbox"/>	<input type="checkbox"/>	.....
Condition sliding blocks.....	<input type="checkbox"/>	<input type="checkbox"/>	<input type="checkbox"/>	.....
Condition colour.....	<input type="checkbox"/>	<input type="checkbox"/>	<input type="checkbox"/>	.....
Construction (deformation, cracking).....	<input type="checkbox"/>	<input type="checkbox"/>	<input type="checkbox"/>	.....
Condition quality of concrete (cracking).....	<input type="checkbox"/>	<input type="checkbox"/>	<input type="checkbox"/>	.....
Torque moment of the dowels.....	<input type="checkbox"/>	<input type="checkbox"/>	<input type="checkbox"/>	.....
Fixed seat of the screws.....	<input type="checkbox"/>	<input type="checkbox"/>	<input type="checkbox"/>	.....
Condition operating unit.....	<input type="checkbox"/>	<input type="checkbox"/>	<input type="checkbox"/>	.....
Condition piston rod and stripper.....	<input type="checkbox"/>	<input type="checkbox"/>	<input type="checkbox"/>	.....
Condition of the covers.....	<input type="checkbox"/>	<input type="checkbox"/>	<input type="checkbox"/>	.....
Condition of hydraulic system and screw fittings...	<input type="checkbox"/>	<input type="checkbox"/>	<input type="checkbox"/>	.....
Level of hydraulic oil .....	<input type="checkbox"/>	<input type="checkbox"/>	<input type="checkbox"/>	.....
Condition hydraulic hoses .....	<input type="checkbox"/>	<input type="checkbox"/>	<input type="checkbox"/>	.....
Condition electrical cables, switches .....	<input type="checkbox"/>	<input type="checkbox"/>	<input type="checkbox"/>	.....
Function test with vehicle.....	<input type="checkbox"/>	<input type="checkbox"/>	<input type="checkbox"/>	.....
Function test wheel free lift with vehicle.....	<input type="checkbox"/>	<input type="checkbox"/>	<input type="checkbox"/>	.....
Condition Polymer supports.....	<input type="checkbox"/>	<input type="checkbox"/>	<input type="checkbox"/>	.....
Condition welding.....	<input type="checkbox"/>	<input type="checkbox"/>	<input type="checkbox"/>	.....
Function CE-Stop + warning signal.....	<input type="checkbox"/>	<input type="checkbox"/>	<input type="checkbox"/>	.....

**( mark here applicable, in case of verification mark in addition to the first mark!)**

Security check carried out:.....

Carried out the company:.....

Name, address of the competent:.....

Result of the Check:

- Initiation not permitted, verification necessary
- Initiation possible, repair failures until.....
- No failings, Initiation possible

.....  
signature of the expert

.....  
signature of the operator

If failures must be repaired:

Failures repaired at: .....  
(Use another form for verification!)

.....  
signature of the operator

**Extraordinary security check**



Filling out and leave in this manual

Serial number: \_\_\_\_\_

kind of check	all right	defect missing	verification	remark
Short Operating instruction.....	<input type="checkbox"/>	<input type="checkbox"/>	<input type="checkbox"/>	.....
Type plate.....	<input type="checkbox"/>	<input type="checkbox"/>	<input type="checkbox"/>	.....
Warning designation, sticker.....	<input type="checkbox"/>	<input type="checkbox"/>	<input type="checkbox"/>	.....
Function button "lifting/lowering".....	<input type="checkbox"/>	<input type="checkbox"/>	<input type="checkbox"/>	.....
Function lever „main lift/wheel free lift“.....	<input type="checkbox"/>	<input type="checkbox"/>	<input type="checkbox"/>	.....
Condition / Function ramp.....	<input type="checkbox"/>	<input type="checkbox"/>	<input type="checkbox"/>	.....
Function play-detector (optional).....	<input type="checkbox"/>	<input type="checkbox"/>	<input type="checkbox"/>	.....
Condition/Function pocket-lamp (optional).....	<input type="checkbox"/>	<input type="checkbox"/>	<input type="checkbox"/>	.....
Security of the bolts.....	<input type="checkbox"/>	<input type="checkbox"/>	<input type="checkbox"/>	.....
Condition bolts and bearings.....	<input type="checkbox"/>	<input type="checkbox"/>	<input type="checkbox"/>	.....
Condition sliding blocks.....	<input type="checkbox"/>	<input type="checkbox"/>	<input type="checkbox"/>	.....
Condition colour.....	<input type="checkbox"/>	<input type="checkbox"/>	<input type="checkbox"/>	.....
Construction (deformation, cracking).....	<input type="checkbox"/>	<input type="checkbox"/>	<input type="checkbox"/>	.....
Condition quality of concrete (cracking).....	<input type="checkbox"/>	<input type="checkbox"/>	<input type="checkbox"/>	.....
Torque moment of the dowels.....	<input type="checkbox"/>	<input type="checkbox"/>	<input type="checkbox"/>	.....
Fixed seat of the screws.....	<input type="checkbox"/>	<input type="checkbox"/>	<input type="checkbox"/>	.....
Condition operating unit.....	<input type="checkbox"/>	<input type="checkbox"/>	<input type="checkbox"/>	.....
Condition piston rod and stripper.....	<input type="checkbox"/>	<input type="checkbox"/>	<input type="checkbox"/>	.....
Condition of the covers.....	<input type="checkbox"/>	<input type="checkbox"/>	<input type="checkbox"/>	.....
Condition of hydraulic system and screw fittings...	<input type="checkbox"/>	<input type="checkbox"/>	<input type="checkbox"/>	.....
Level of hydraulic oil .....	<input type="checkbox"/>	<input type="checkbox"/>	<input type="checkbox"/>	.....
Condition hydraulic hoses .....	<input type="checkbox"/>	<input type="checkbox"/>	<input type="checkbox"/>	.....
Condition electrical cables, switches .....	<input type="checkbox"/>	<input type="checkbox"/>	<input type="checkbox"/>	.....
Function test with vehicle.....	<input type="checkbox"/>	<input type="checkbox"/>	<input type="checkbox"/>	.....
Function test wheel free lift with vehicle.....	<input type="checkbox"/>	<input type="checkbox"/>	<input type="checkbox"/>	.....
Condition Polymer supports.....	<input type="checkbox"/>	<input type="checkbox"/>	<input type="checkbox"/>	.....
Condition welding.....	<input type="checkbox"/>	<input type="checkbox"/>	<input type="checkbox"/>	.....
Function CE-Stop + warning signal.....	<input type="checkbox"/>	<input type="checkbox"/>	<input type="checkbox"/>	.....

**( mark here applicable, in case of verification mark in addition to the first mark!)**

Security check carried out:.....

Carried out the company:.....

Name, address of the competent:.....

Result of the Check:

- Initiation not permitted, verification necessary
- Initiation possible, repair failures until.....
- No failings, Initiation possible

.....  
signature of the expert

.....  
signature of the operator

If failures must be repaired:

Failures repaired at: .....  
(Use another form for verification!)

.....  
signature of the operator



**Extraordinary security check**



Filling out and leave in this manual

Serial number: \_\_\_\_\_

kind of check	all right	defect missing	verification	remark
Short Operating instruction.....	<input type="checkbox"/>	<input type="checkbox"/>	<input type="checkbox"/>	.....
Type plate.....	<input type="checkbox"/>	<input type="checkbox"/>	<input type="checkbox"/>	.....
Warning designation, sticker.....	<input type="checkbox"/>	<input type="checkbox"/>	<input type="checkbox"/>	.....
Function button "lifting/lowering".....	<input type="checkbox"/>	<input type="checkbox"/>	<input type="checkbox"/>	.....
Function lever „main lift/wheel free lift“.....	<input type="checkbox"/>	<input type="checkbox"/>	<input type="checkbox"/>	.....
Condition / Function ramp.....	<input type="checkbox"/>	<input type="checkbox"/>	<input type="checkbox"/>	.....
Function play-detector (optional).....	<input type="checkbox"/>	<input type="checkbox"/>	<input type="checkbox"/>	.....
Condition/Function pocket-lamp (optional).....	<input type="checkbox"/>	<input type="checkbox"/>	<input type="checkbox"/>	.....
Security of the bolts.....	<input type="checkbox"/>	<input type="checkbox"/>	<input type="checkbox"/>	.....
Condition bolts and bearings.....	<input type="checkbox"/>	<input type="checkbox"/>	<input type="checkbox"/>	.....
Condition sliding blocks.....	<input type="checkbox"/>	<input type="checkbox"/>	<input type="checkbox"/>	.....
Condition colour.....	<input type="checkbox"/>	<input type="checkbox"/>	<input type="checkbox"/>	.....
Construction (deformation, cracking).....	<input type="checkbox"/>	<input type="checkbox"/>	<input type="checkbox"/>	.....
Condition quality of concrete (cracking).....	<input type="checkbox"/>	<input type="checkbox"/>	<input type="checkbox"/>	.....
Torque moment of the dowels.....	<input type="checkbox"/>	<input type="checkbox"/>	<input type="checkbox"/>	.....
Fixed seat of the screws.....	<input type="checkbox"/>	<input type="checkbox"/>	<input type="checkbox"/>	.....
Condition operating unit.....	<input type="checkbox"/>	<input type="checkbox"/>	<input type="checkbox"/>	.....
Condition piston rod and stripper.....	<input type="checkbox"/>	<input type="checkbox"/>	<input type="checkbox"/>	.....
Condition of the covers.....	<input type="checkbox"/>	<input type="checkbox"/>	<input type="checkbox"/>	.....
Condition of hydraulic system and screw fittings... Level of hydraulic oil .....	<input type="checkbox"/>	<input type="checkbox"/>	<input type="checkbox"/>	.....
Condition hydraulic hoses .....	<input type="checkbox"/>	<input type="checkbox"/>	<input type="checkbox"/>	.....
Condition electrical cables, switches .....	<input type="checkbox"/>	<input type="checkbox"/>	<input type="checkbox"/>	.....
Function test with vehicle.....	<input type="checkbox"/>	<input type="checkbox"/>	<input type="checkbox"/>	.....
Function test wheel free lift with vehicle.....	<input type="checkbox"/>	<input type="checkbox"/>	<input type="checkbox"/>	.....
Condition Polymer supports.....	<input type="checkbox"/>	<input type="checkbox"/>	<input type="checkbox"/>	.....
Condition welding.....	<input type="checkbox"/>	<input type="checkbox"/>	<input type="checkbox"/>	.....
Function CE-Stop + warning signal.....	<input type="checkbox"/>	<input type="checkbox"/>	<input type="checkbox"/>	.....

**( mark here applicable, in case of verification mark in addition to the first mark!)**

Security check carried out:.....

Carried out the company:.....

Name, address of the competent:.....

Result of the Check:

- Initiation not permitted, verification necessary
- Initiation possible, repair failures until.....
- No failings, Initiation possible

.....  
signature of the expert

.....  
signature of the operator

If failures must be repaired:

Failures repaired at: .....  
(Use another form for verification!)

.....  
signature of the operator

Nussbaum Custom Lifts GmbH • Customer Service • Hertzstr. 6 • D 77694 Kehl  
[www.nussbaumlifts.com](http://www.nussbaumlifts.com) • e-Mail: [service@nussbaum-group.de](mailto:service@nussbaum-group.de)

Service Hotline Germany: 0800 5 288 911  
Service Hotline International: +49 180 5 288 911  
975395 UNI LIFT 3500 NT – 3500 NT PLUS OPI | EN | Version 3.0