

4.40H / 4.40H Plus

Automotive lift date: 04/2007

Manual date: 01.04.2012

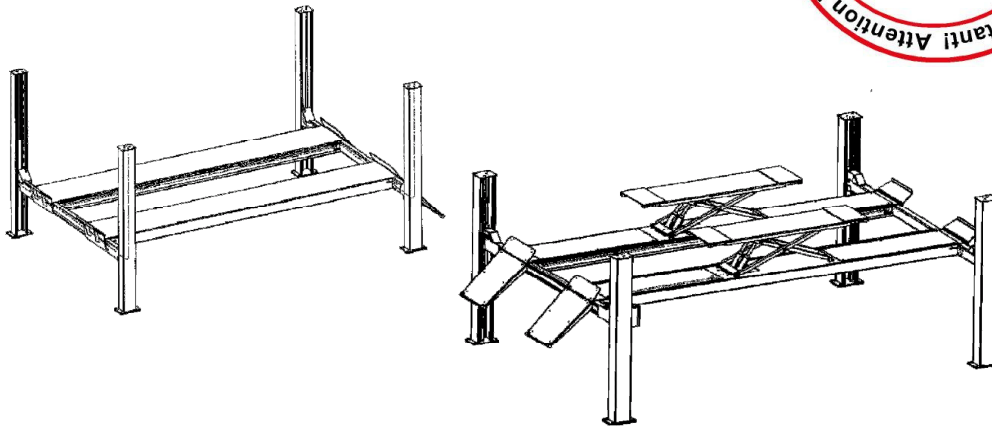

Original Documentation

Operating Instruction and Documentation

Serial number:.....

Retailer address / phone



Nussbaum

Otto Nußbaum GmbH & Co. KG//Korker Straße 24//D-77694 Kehl-Bodersweier

Tel: +49(0)7853/8990 Fax: +49(0)7853/8787

E-Mail: info@nussbaum-lifts.de // <http://www.nussbaum-lifts.de>

Attention! Important information for the installation!

After the generally adjustment of the automotive lift all ropes must be locked at the rope-terminal and an the top of all 4 columns as followed:

1. move the locking plate on the ropes to the block(position as shown on pic.1)
2. put the cylinder screw M5x20 DIN912 with a disc M5 DIN125A in the slit of the plate
3. move the plate, so that the screw is on the end of the slit
4. counter the screw with help of a self-locking hex-nut M5 DIN985 and a disc M5 DIN125A
Attention! Don't lock the plate on the rope terminal! It must be movable!
5. on opposite side of the terminal each of the ropes must be counter-locked with 2 hex-nuts M12 DIN934 (pic. 2)

slit of the locking plate

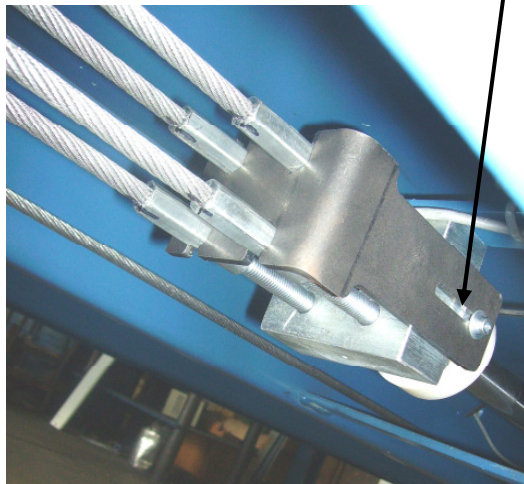

pic.1 assembling of the locking plate
(sight from below)

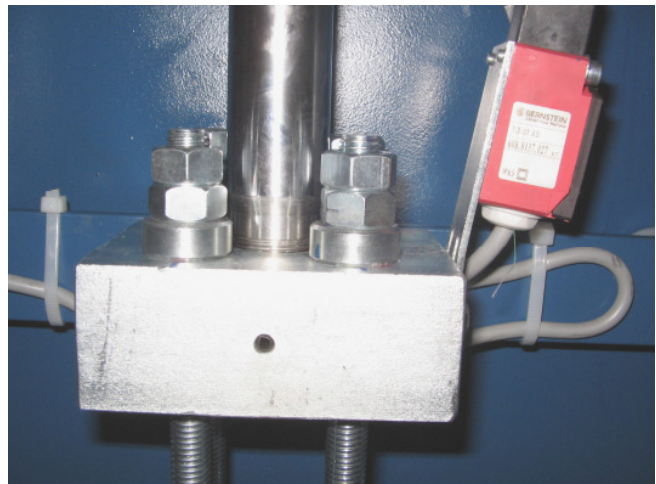

pic. 2



pic.3 counter-locking of the rope on top of column with 2 hex-nuts M12 DIN934
(see example for one Column)

Contents

FOREWORD.....	4
RECORD OF INSTALLATION.....	6
RECORD OF HANDING OVER.....	7
1. INTRODUCTION.....	8
1.1 INSTALLATION AND CHECK OF THE AUTOMOTIVE LIFT.....	8
1.2 INFORMATION OF WARNING.....	8
2. MASTER DOCUMENT OF THE AUTOMOTIVE LIFT.....	9
2.1 LIFT –MANUFACTURER.....	9
2.2 APPLICATION.....	9
2.3 CHANGES AT THE CONSTRUCTION.....	9
2.4 DISPLACEMENT OF THE AUTOMOTIVE-LIFT.....	9
2.5 ATTESTATION OF CONFORMITY.....	10
3. TECHNICAL INFORMATION.....	11
3.1 TECHNICAL RATINGS.....	11
3.2 SAFETY DEVICE.....	11
3.3 DATASHEET.....	12
3.4 FOUNDATION DIAGRAM DRAWING.....	15
3.5 HYDRAULIC DIAGRAM WITHOUT WHEEL FREE LIFT.....	18
3.6 HYDRAULIC DIAGRAM WITH WHEEL FREE LIFT.....	19
3.7 ELECTRICAL DIAGRAM DRAWING WITHOUT WHEEL FREE LIFT.....	21
3.8 ELECTRICAL DIAGRAM DRAWING WITH WHEEL FREE LIFT.....	23
3.9 ELECTRICAL DIAGRAM DRAWING WITH 3 x 230 V.....	25
3.11 CONNECTION-COMMAND (PICTURES).....	26
4. SAFETY REGULATIONS.....	31
5. OPERATING INSTRUCTIONS.....	31
5.1 LIFTING THE VEHICLE WITH AUTOMOTIVE LIFT.....	31
5.2 LOWERING THE VEHICLE WITH THE AUTOMOTIVE LIFT.....	33
5.3 LOWERING THE AUTOMOTIVE LIFT IN THE RATCHET STRIP (WHEEL ALIGNMENT).....	33
5.4 RAISE THE AUTOMOTIVE LIFT OUT OF THE RATCHET STRIP.....	33
5.5 FUNCTION OF THE OVERRIDE SWITCH.....	33
6. TROUBLESHOOTING.....	34
6.1 DRIVING ON AN OBSTACLE WITH THE MAIN LIFT.....	34
6.2 EMERGENCY LOWERING IN CASE OF POWER FAILURE OR DEFECTIVE VALVE.....	34
7. MAINTENANCE.....	35
7.1 INSPECTION AND MAINTENANCE.....	36
7.2 CLEANING OF THE AUTOMOTIVE LIFT.....	37
8. SECURITY CHECK.....	37
9. INSTALLATION AND INITIATION.....	38
9.1 REGULATIONS FOR THE INSTALLATION.....	38
9.2 ERECTION AND DOWELING OF THE LIFT.....	38
9.3 ADJUSTING THE RAIL.....	41
9.4 INITIATION.....	41
9.5 CHANGING THE INSTALLATION PLACE.....	41
9.6 POSITION OF THE COLUMNS.....	42
FIRST SECURITY CHECK BEFORE INSTALLATION.....	46
REGULAR SECURITY CHECK.....	47
EXTRAORDINARY SECURITY CHECK.....	55

Foreword

Nußbaum lifting systems are the result of over 25 years experience in the automotive lifting industry. The high quality and the superior concept ensure reliability, a long lift lifetime and above all and economic business solution.

To avoid unnecessary damage, injury or even death, read the operating instructions with care and observe the contents.

Nußbaum lifts is not responsible for incidents involving the use of Nußbaum lifting systems for applications other than those for which they were designed.

Otto Nußbaum GmbH & Co. KG is not liable for any resulting damages. The user carries the risk alone.

Obligations of the user:

- To observe and adhere to the operating instructions.
- To follow the recommended inspection and maintenance procedures and carry out the prescribed tests.
- The operating instructions must be observed by all persons working with or around the lift.
- Above all chapter 4 "Safety Regulations" is very important and must be closely adhered to.
- In addition to the safety regulations stated in the operating instructions manual, the appropriate safety regulations and the operating procedures of the place of operation must also be considered.

Obligations of the operator:

The operator is obliged to allow only those persons complying to the following requirements to work with or around the unit.

- Persons being familiar with the basic regulations concerning labour safety and accident prevention and being trained to operate the particular unit.
- Persons having read and understood the chapter concerning safety and warning symbols.
- Persons using the lift are required to confirm that they have read and understood the chapter on safety and warning symbols by signing the appropriate form.

Dangers when operating the lift:

Nußbaum-Lifts are designed and built according to technical standards and the approved regulations for technical safety. The use of Nußbaum lifts for purposes other than those for which they were designed, may result in injury or even death.

The lift must only be operated :

- For its appropriate use
- In faultless condition concerning technical security.

Organisational Requirements

- The instructions for use are to be kept at the place of operation being easily accessible at any time.
- In addition to the instructions for use, rules pertaining to other regulations i.e. accident prevention and environmental rules are to be observed and adhered to.
- The owner of the Nußbaum lifting system must ensure that operators and persons working with or around the lift occasionally conduct “refresher” courses to ensure that the appropriate operating procedures and safety precautions are known.
- Personal Protective Equipment (PPE) must be used according to the appropriate regulations.
- All safety- and danger signs on and around the lift are to be observed and followed!
- Spare parts must comply with the technical requirements specified by the manufacturer. This is only warranted with original parts.
- Observe and adhere to the specified time intervals between tests and inspections.

Maintenance works, repairing faults

- Adjustments, maintenance, and inspections, are to be followed according to the time intervals specified. Details regarding the exchange of parts and components as mentioned in the operating instructions are to be adhered to.
These works must only be carried out by expert personal.
- After maintenance- and repair works loose screws, nuts and bolts must always be firmly tightened!

Guarantee and liability

- Our “General conditions of selling and delivering” are in force.
There will be no guarantee or liability for incidents involving injuries or death or damage to equipment if these incidents are the result of one or more of the following reasons.
- Inappropriate use of the lift
- Inappropriate installation, initiation, operation and maintenance of the lift.
- Use of the lift while one or several security devices do not work, do not work correctly or are not installed correctly.
- Failure to follow the regulations of the operating instructions regarding transport, storage, installation, initiation, operation and maintenance of the lift.
- Unauthorized changes to the structure of the lift without first asking the producer.
- Unauthorized changes of adjustments of important components of the lift (e.g. driving elements, power rating, motor speed, etc)
- Wrong or incorrect maintenance practice.
- Catastrophes, acts of God or external reasons.



Filling out and undersigned and copying this sheet and send the original to the lift manufacturer. The copy remains in the Manual.

Otto Nußbaum GmbH & Co. KG
Korker Straße 24
D-77694 Kehl-Bodersweier

Record of installation

The automotive lift 4.40 / 4.40 H Plus with the

serial number:..... was installed on:.....

at the firm:..... at:.....

the safety was checked and the lift was started.

The installation was effected from the operating authority/competent (please delete as applicable).

The safety of the automotive lift was checked from the competent before the initial operation.

The operating authority attest the installation of the automotive lift, the competent attest the correct initial operation.

.....
date name of the operating authority signature of the operating authority

.....
date name of the competent person signature of the competent person

Your customer service:.....

automotive lift date: 09/99 manual date: 03.11.99

Record of handing over

The automotive lift 4.40 / 4.40 H Plus with the

serial number:..... was installed on:.....

at the firm:..... at:.....

the safety was checked and the lift was started.

The persons below were introduced after the installation of the automotive lift. The introduction was carried out from an erector of the lift-manufacturer or from a franchised dealer (competent person).

..... date name signature
---------------	---------------	--------------------

..... date name signature
---------------	---------------	--------------------

..... date name signature
---------------	---------------	--------------------

..... date name signature
---------------	---------------	--------------------

..... date name signature
---------------	---------------	--------------------

..... date name signature
---------------	---------------	--------------------

..... date name of competent signature of the competent
---------------	----------------------------	-------------------------------------

Your customer service:.....

1. Introduction

The document "**Operating Instructions and Documentation**" contains important information about installation, operation and maintenance of the lift.

To furnish proof of **installation of the automotive lift** the form "Record of Installation" must be signed and returned to the manufacturer.

To furnish proof of the singular, felt this documentation contains forms. The forms should be used to document the checks. They should not be removed from this documentation.

Every **Changes to the construction** and **displacement** of the automotive lift must be registered in the "**Master document**" of the lift.

1.1 Installation and check of the automotive lift

Only specialist staff is allowed to do work concerning safety and to do the safety checks of the lift. They are called experts and competent person in this document.

Experts are persons (for example self-employed engineers, experts) which have received instruction and have experience to check and to test automotive lifts. They know the relevant labour and accidents prevention regulations.

Competent person are persons who have acquired adequate knowledge and experience with automotive lifts. They took part in training from the lift-manufacturer (servicing technicians of the manufacturer or dealer, are competent)

1.2 Information of Warning

To show danger and to show important information the three symbols below are used. Pay attention to those passages, which are marked with these symbols



Danger! This sign indicates danger to life. Inexpert handling of the described operation may be dangerous to life.



Caution! This sign cautions against possible damage to the automotive lift or other material defects in case of inexpert handling.



Attention! This sign indicates for an important function or other important notes.

2. Master document of the automotive lift

2.1 Lift –Manufacturer

Otto Nußbaum GmbH & Co. KG
Korker Straße 24
D-77694 Kehl-Bodersweier

2.2 Application

The automotive lift **4.40 / 4.40 H Plus** is a lifting mechanism for lifting motor vehicles with a laden weight of up to 4000 kg (4.40 H). The max. load distribution (4.40H) is 2:1 in or against drive-on direction. The automotive lift is only designed for servicing vehicles. It is not allowed to carry persons with the lift.

The wheel free lift is a lifting mechanism for lifting motor vehicles with a laden weight of up to 2500 kg. The max. load distribution is 2:3 in or against drive-on direction.

It's not allowed to install the standard-automotive lift in a hazardous location or washing bays.

2.3 Changes at the construction

Changes at the construction, expert checking, resumption of work (date, kind of change, signature of the expert)

.....
.....
.....
.....

name, address of the expert

.....

place, date

.....

signature of the expert

2.4 Displacement of the automotive-lift

Displacement of the automotive-lift, expert checking, resumption of work (date, kind of change, signature of the competent)

.....
.....
.....
.....

name, address of the competent

.....

place, date

.....

signature of the competent

2.5 Attestation of conformity

EG- Konformitätserklärung



gemäß Maschinenrichtlinie Anhang II 1A

Declaration of Conformity according Machinery Directive 2006/42/EG ANNEX II 1A
Déclaration de conformité selon directive machines annexe II 1A
Declaración de conformidad según Directiva Maquinaria 2006/42/EG ANNEX II 1A
Dichiarazione di conformità in accordo alla direttiva 2006/42/EG ANNEX II 1A

Hiermit erklären wir, daß die Hebebühne, Modell:
Hereby we declare that the lift, model:
Par là présente nous déclarons que le pont éleveur, modèle:
Por là presente declaramos, que el elevador, modelo:
Con là presente si dichiara che il sollevatore:

COMBI LIFT
COMBI LIFT 4.40 H
COMBI LIFT 4.40 H A
COMBI LIFT 4.40 H Plus
COMBI LIFT 4.40 H Plus A

allen einschlägigen Bestimmungen der folgenden Richtlinien entspricht:
fills all the relevant provisions of the following Directives
correspond aux normes suivantes:
cumple todas las disposiciones pertinentes de las Directivas siguientes:
adempió a tutte le richieste delle seguenti direttive:

Maschinenrichtlinie / Machinery Directive
EMV Richtlinie / EMC Directive

2006/42/EG
2004/108/EG

in Übereinstimmung mit den folgenden harmonisierten Normen gefertigt wurde
was manufactured in conformity with the harmonized norms
fabriqué en conformité selon les normes harmonisées en vigueur:
producido de acuerdo a las siguientes normas armonizadas
è stato fabbricato in conformità con le norme armonizzate

Fahrzeug- Hebebühnen / Vehicle lifts
Elektromagnetische Verträglichkeit / Electromagnetic compatibility (EMC)

EN 1493: 2010
EN 61000-6-2, -6-4

Baufragter für die Technische Dokumentation
Authorized to compile the technical file

Otto Nussbaum GmbH & Co. KG

Seriennummer
Serial number

Seriennummer

Kehl-Bodersweier, 12.03.2012

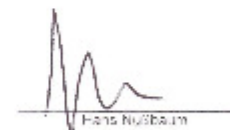

Hans Nussbaum

EMC Combi Lift 2012 01/03



Otto Nussbaum GmbH & Co. KG · Kerkir Str. 24 · D-77694 Kehl-Bodersweier
Tel.: +49(0)7863/899-0 · Fax: +49(0)7863/8787 · www.nussbaum-lifts.de



3. Technical Information

3.1 Technical ratings

Capacity automotive lift:	4000 kg (4.40H)
Load distribution:	2:1 in or against drive-on direction
Lifting time automotive lift:	approx. 30 sec.
Lowering time automotive lift:	approx. 25 sec.
Lifting height:	max. 1800mm
Capacity wheel free lift:	2500 kg
Lifting height:	approx.442 mm
Drive on height:	approx. 68 mm
Line voltage:	3 x 400 Volt , 50Hz
Driving voltage	24 Volt
Power rating:	3 kW
Motor speed:	2800 rotation/min
Pump capacity:	3 cm ³ /revolution
Hydraulic pressure:	approx. 245 bar
Pressure relief valve:	approx. 270 bar
Oil tank:	approx. 10 litre - viscosity 32 cst.
Sound level L _{pA}	≤ 70 dB
Connection by customer (standard)	3~/N+PE, 400V, 50 Hz with fuse 16A T (Pay attention to the voltage of your country)

3.2 Safety device

1. Pressure relief valve
Overprint-safety of the hydraulic system
2. Holding valve
safety device against unintentional lowering
3. Key-operated switch
safety against unauthorized operation
4. Safety ratchet
safety device against unintentional lowering
5. Safety limit switch
if a rope breaks, the automotive lift switches off
6. CE-STOP
the automotive lift stops automatically 200 mm before the lowest position

3.3 Datasheet

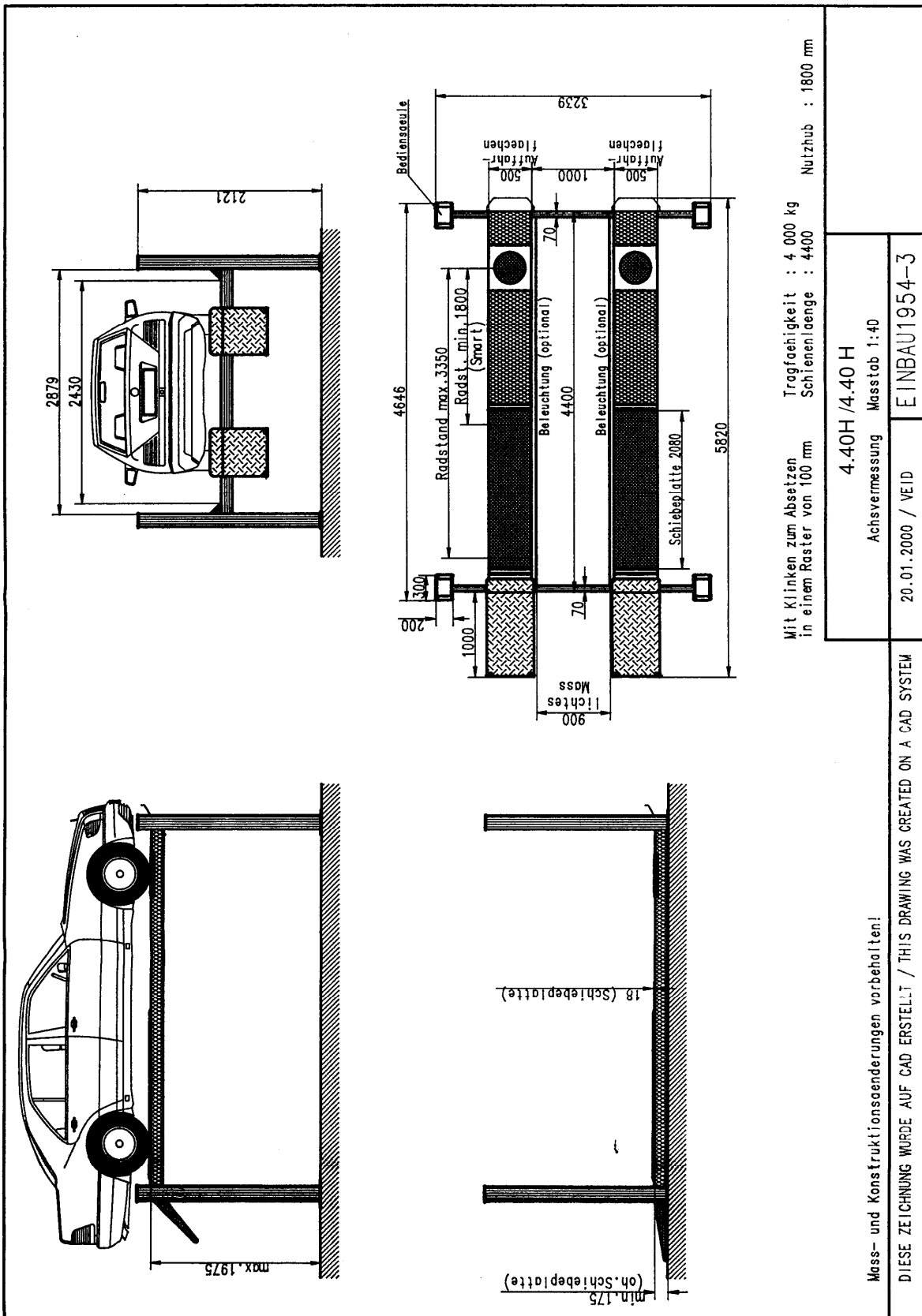

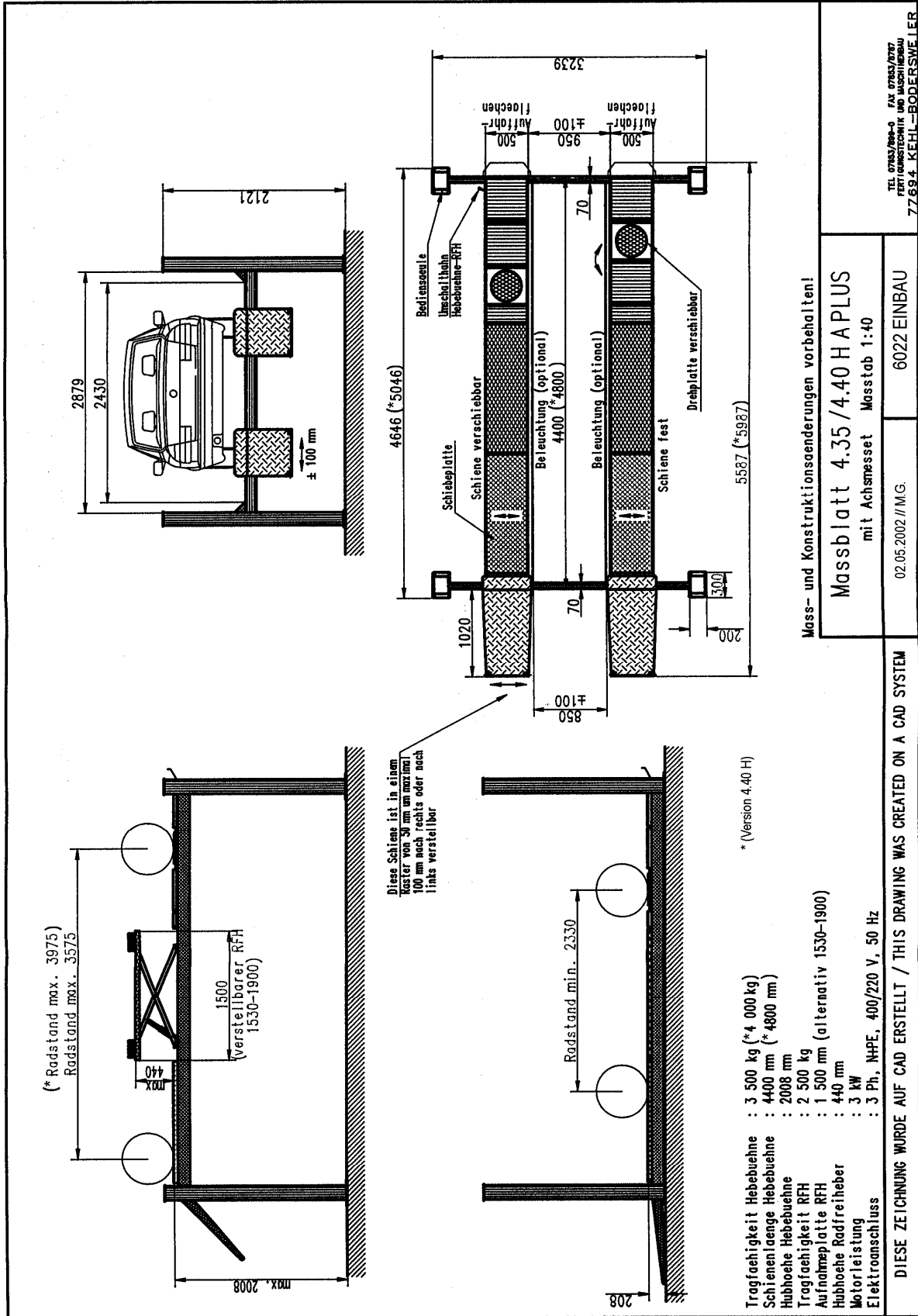

Mass- und Konstruktionsänderungen vorbehalten!

Massblatt 4.35 / 4.40 H PLUS

mit Achsmesset Masstab 1:40

02.05.2002 // M.G.

6022 EINBAU

TEL 0785/3084-0 FAX 0785/3077
 FERTIGUNGSTECHNIK UND MASCHINENBAU
 77694 KEHL-BODERSWEILER

DIESE ZEICHNUNG WURDE AUF CAD ERSTELLT / THIS DRAWING WAS CREATED ON A CAD SYSTEM

(* Radstand max. 3975)
Radstand max. 3575

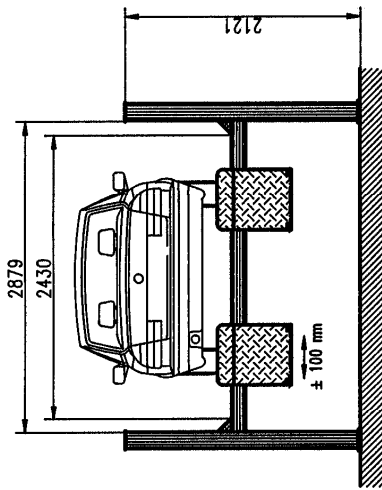
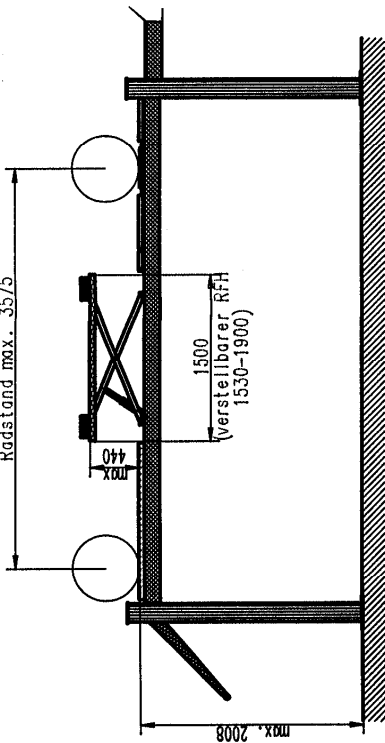

Diese Schiene ist in einem
Kasten von 30 mm an maximal
100 mm nach rechts oder nach
links verstellbar

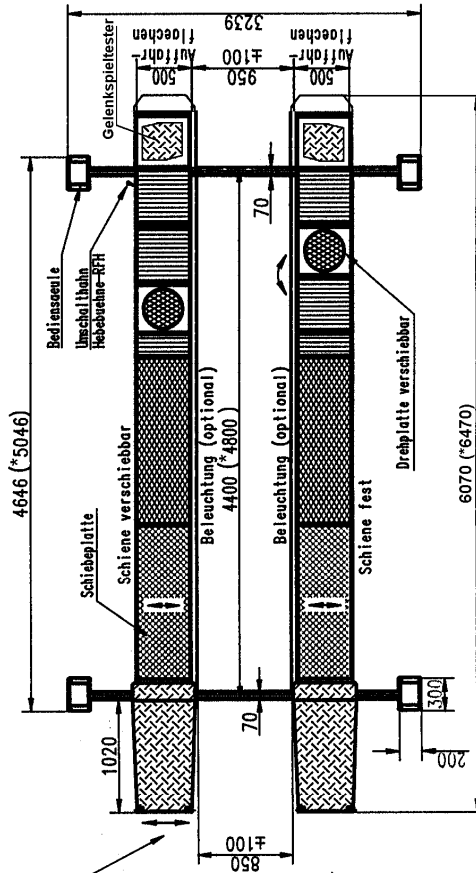
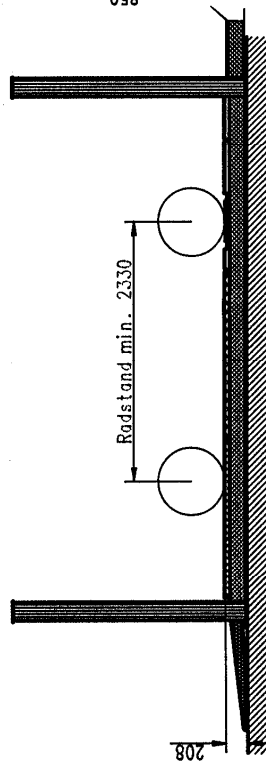

** (Version 4.40 H)

- Tragfähigkeit Hebebühne : 3 500 kg (** 4 000 kg)
- Schiene Länge Hebebühne : 4400 mm (* 4800 mm)
- Hubhöhe Hebebühne : 2008 mm
- Tragfähigkeit RfH : 2 500 kg
- Aufnahmeplatte RfH : 1 500 mm (alternativ 1530-1900)
- Hubhöhe Radfreiheber : 440 mm
- Motorleistung : 3 kW
- Elektroanschluss : 3 Ph., NPE, 400/220 V, 50 Hz

Mass- und Konstruktionsänderungen vorbehalten!

Massblatt 4.35 / 4.40 H PLUS

mit Achsmessset / Spid
Masstab 1:40

08.10.2002 // M.G.

6022-1 EINBAU

NUSSBAUM
HEBETECHNIK

FAX 07543/2086-0
TEL 07543/2086-1
FERTIGUNGSTECHNIK UND MASCHINENBAU
77694 KEHL-BODERSWEILER

DIESE ZEICHNUNG WURDE AUF CAD ERSTELLT / THIS DRAWING WAS CREATED ON A CAD SYSTEM

3.4 Foundation diagram drawing

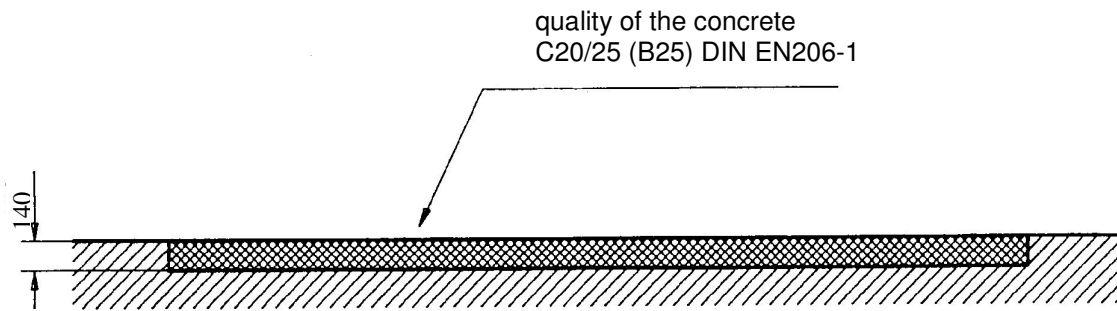

platform length: 4400 (*4800mm ** 5500mm)

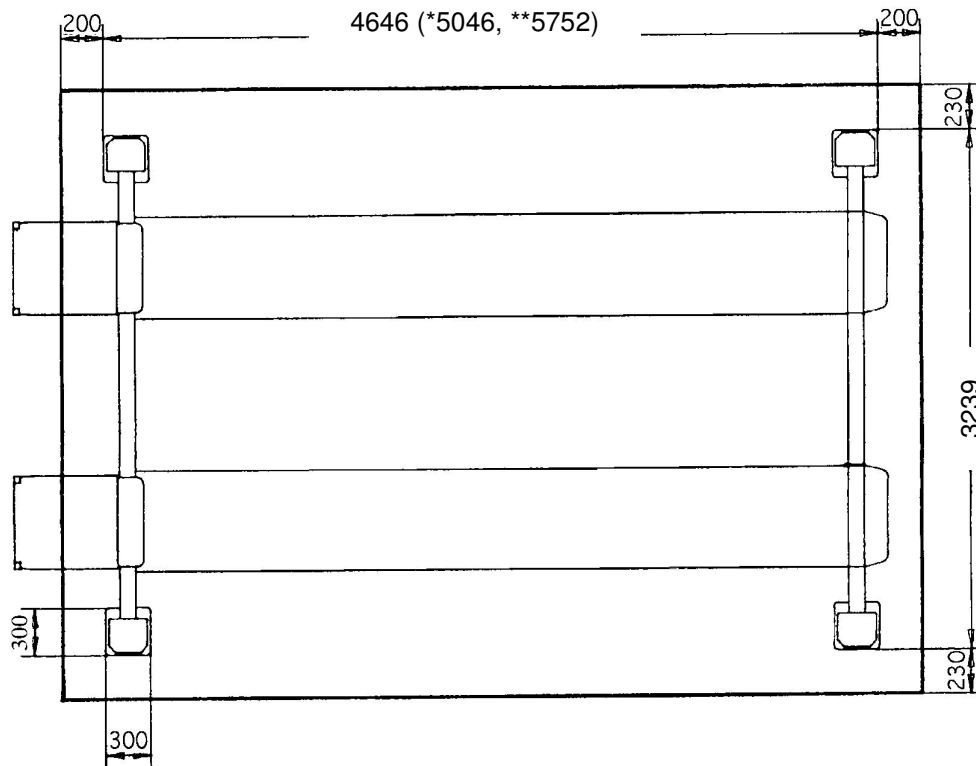

If the concrete is available the quality C20/25 (B25) and the thickness minimum 140 mm must be guaranteed.

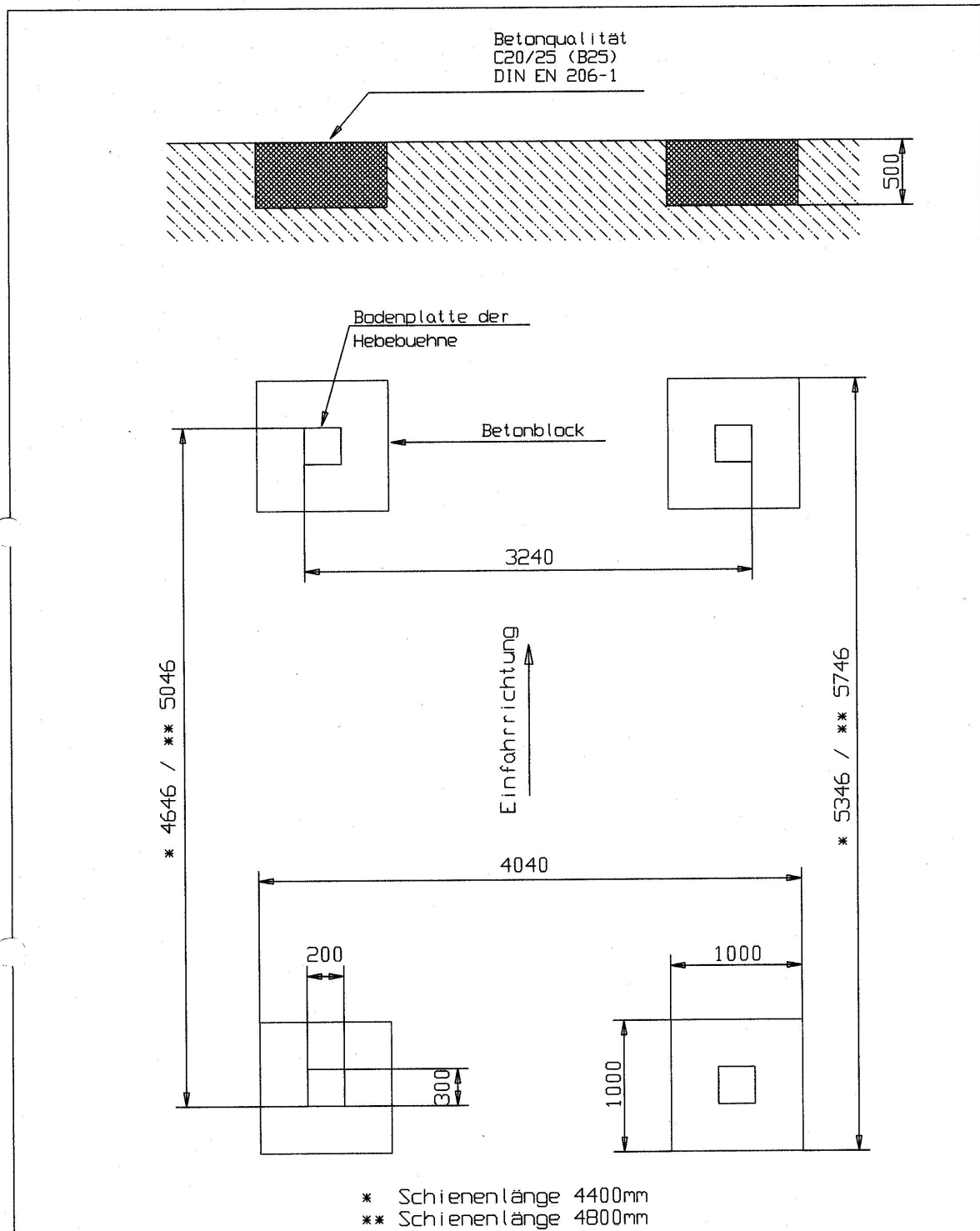

4.35 H / 4.40 H
Block fundamentplan

12.06.05 // M.G.

0816-1_EINBAU

Nussbaum
HEBETECHNIK

TEL 07853/899-0 FAX 07853/8787
FERTIGUNGSTECHNIK UND MASCHINENBAU
77694 KEHL-BODERSWEIER

This is an example:
You can mounting the ramp on this
side of the rails or on the other side
of the rails

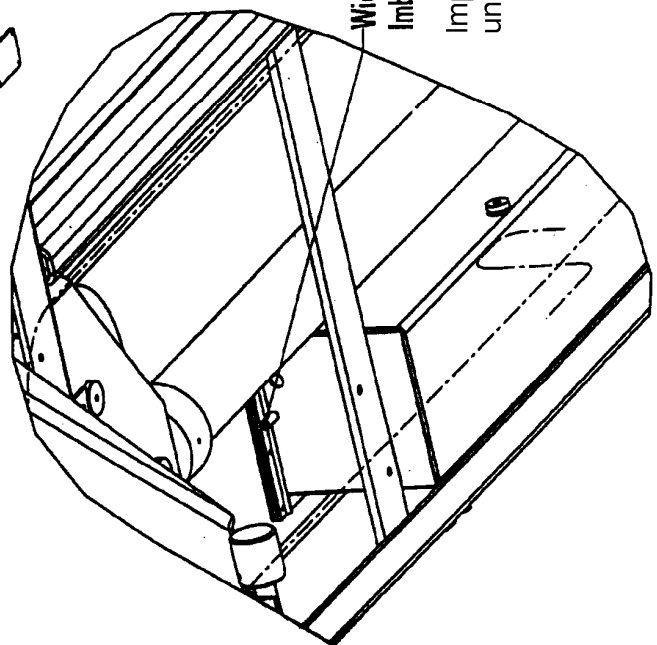
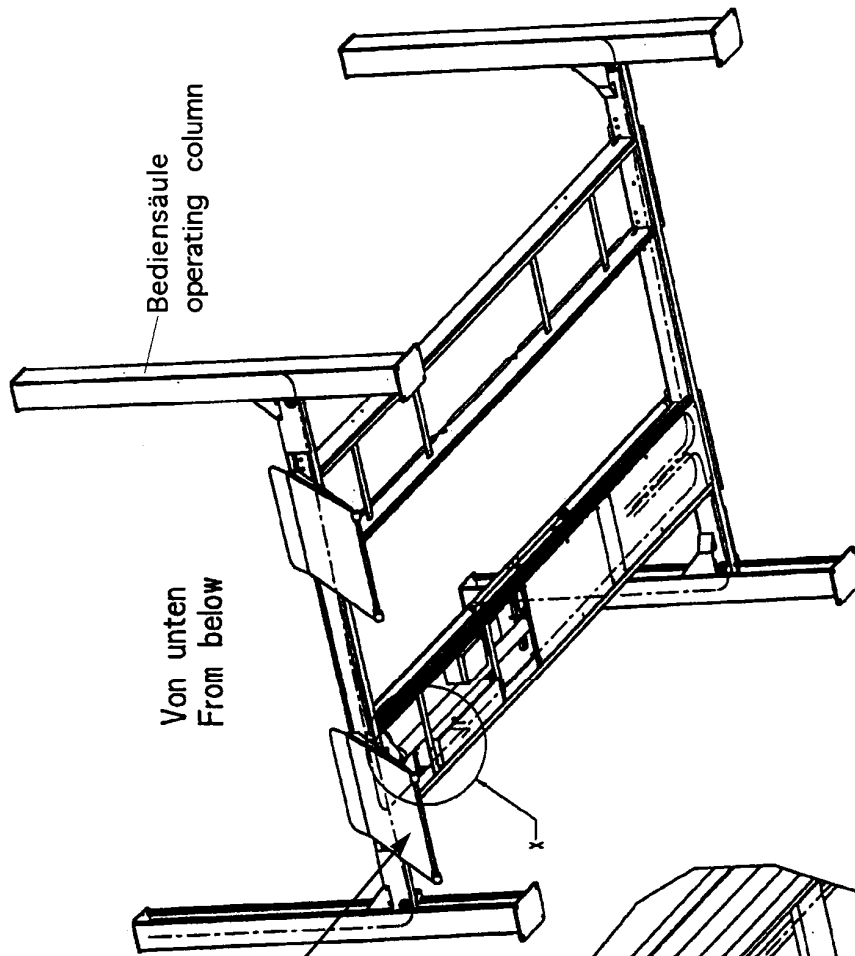

Wichtig: Vor Inbetriebnahme der 4-Säulenhebeuehne
Imbusschraube M6x20 vollständig aus Hydraulik-Aggregat herausdrehen.

Important: Before first initiation
unscrew the screw completely from hydraulic unit

3.5 Hydraulic diagram without wheel free lift

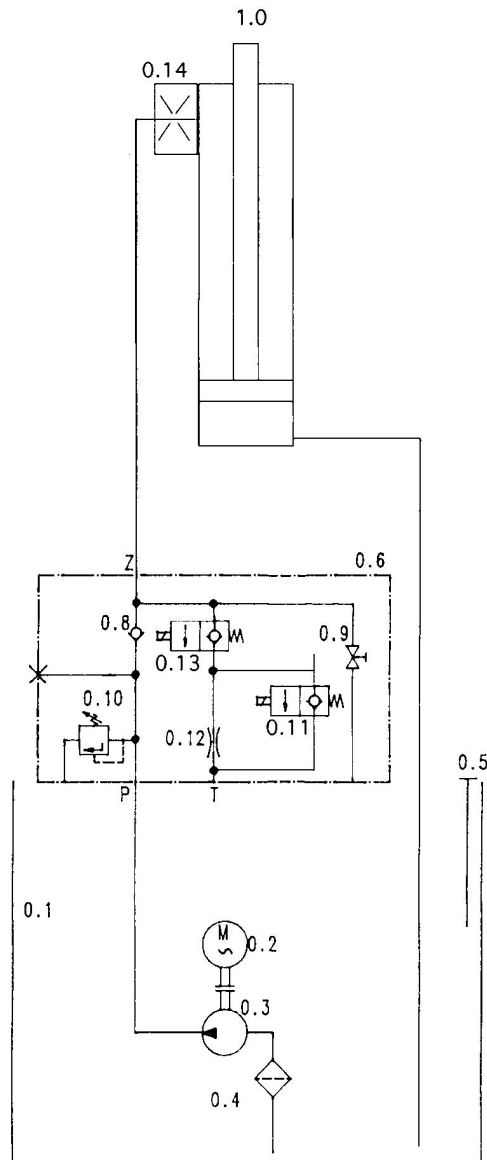

Hydraulic parts list

- 0.1 Oil tank
- 0.2 Sub oil motor
- 0.3 Gear pump
- 0.4 Filter
- 0.5 Oil level gauge
- 0.6 Hydraulic block complete
- 0.8 Holding valve
- 0.9 Emergency lowering screw
- 0.10 pressure control valve
- 0.11 electrical holding valve
- 0.12 flow control valve
- 0.13 electrical holding valve
- 0.14 set screw with a bore hole
- 1.0 Cylinder

3.6 Hydraulic diagram with wheel free lift

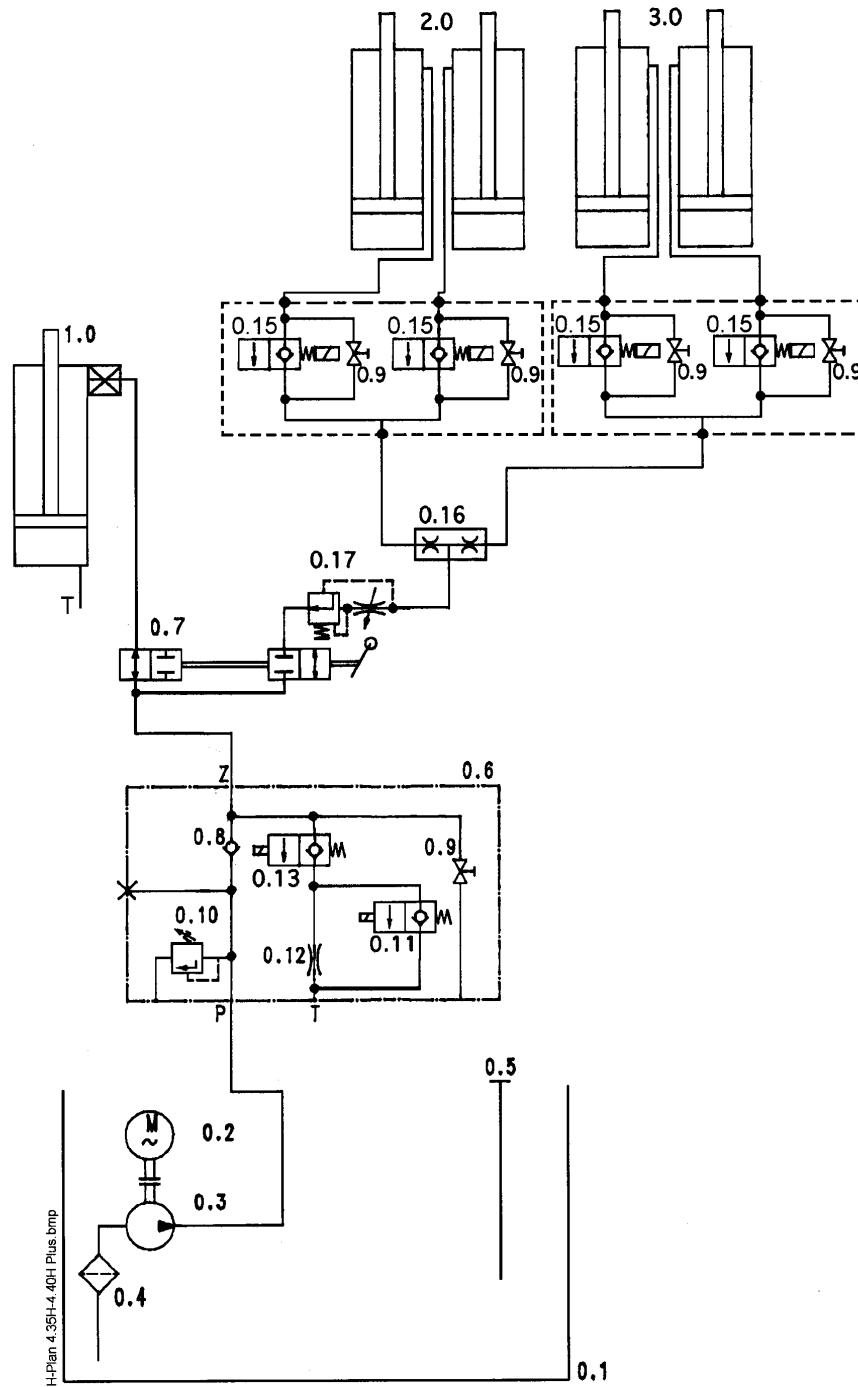

H-Plan 4.35H-4.40H Plus.bmp

Parts List

0.1	oil tank	435H01003
0.2	motor	990445
0.3	gear pump	980486
0.4	filter	980201
0.5	screw	9VSTIR1/4ED
0.6	hydraulic block complete	435H01073
0.7	ball valve (main lift / wheel free lift)	980513
0.8	holding valve	980480
0.9	emergency lowering screw	9232TTL42038
0.10	pressure relief valve	232NSTL02082
0.11	magnetic valve	980478
0.12	screen	
0.13	magnetic valve	980478
0.15	magnetic valve	980478
0.16	flow control valve	
0.17	lowering valve (active during lowering)	980247
1.0	cylinder main lift	435H02000
2.0	cylinder wheel free lift	
3.0	cylinder wheel free lift	

3.7 Electrical diagram drawing without wheel free lift

These electrical diagrams are valid for 4.40H.

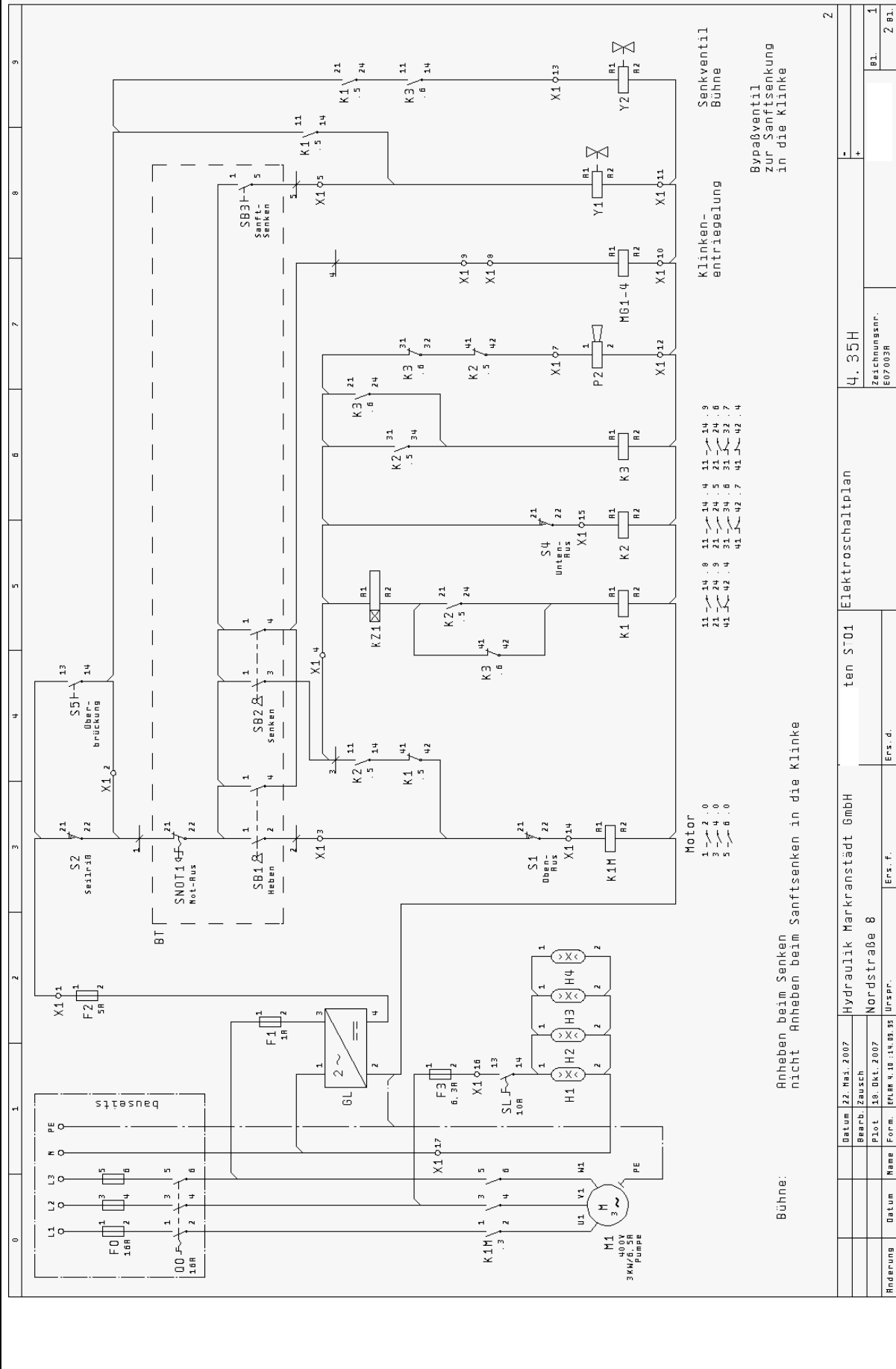

Electrical part list

A1:	main switch (by customer)
M1:	motor
KM1:	up contactor
T1:	key switch
T2:	key switch
T3:	button soft lowering in the ratchets (main lift)
S1:	top limit switch (main lift)
S2:	limit switch „the rope is torn“
S4:	limit switch „CE-Stop“ the main lift is approx. 200 mm over the floor
S5:	override switch
d1-d3:	relays
P*:	loudspeaker
MG1:	electromagnetic (ratchet)
MG2:	electromagnetic (ratchet)
MG3:	electromagnetic (ratchet)
MG4:	electromagnetic (ratchet)
TR:	Transformer 230V/24V
GL:	rectifier
F1:	fuse 0,5 A
F2:	fuse 5A
F3:	fuse 10A
Y1:	override valve (soft lowering)
Y2:	valve (main lift)
KZ1:	time relay
H1-H4:	lighting

3.8 Electrical diagram drawing with wheel free lift

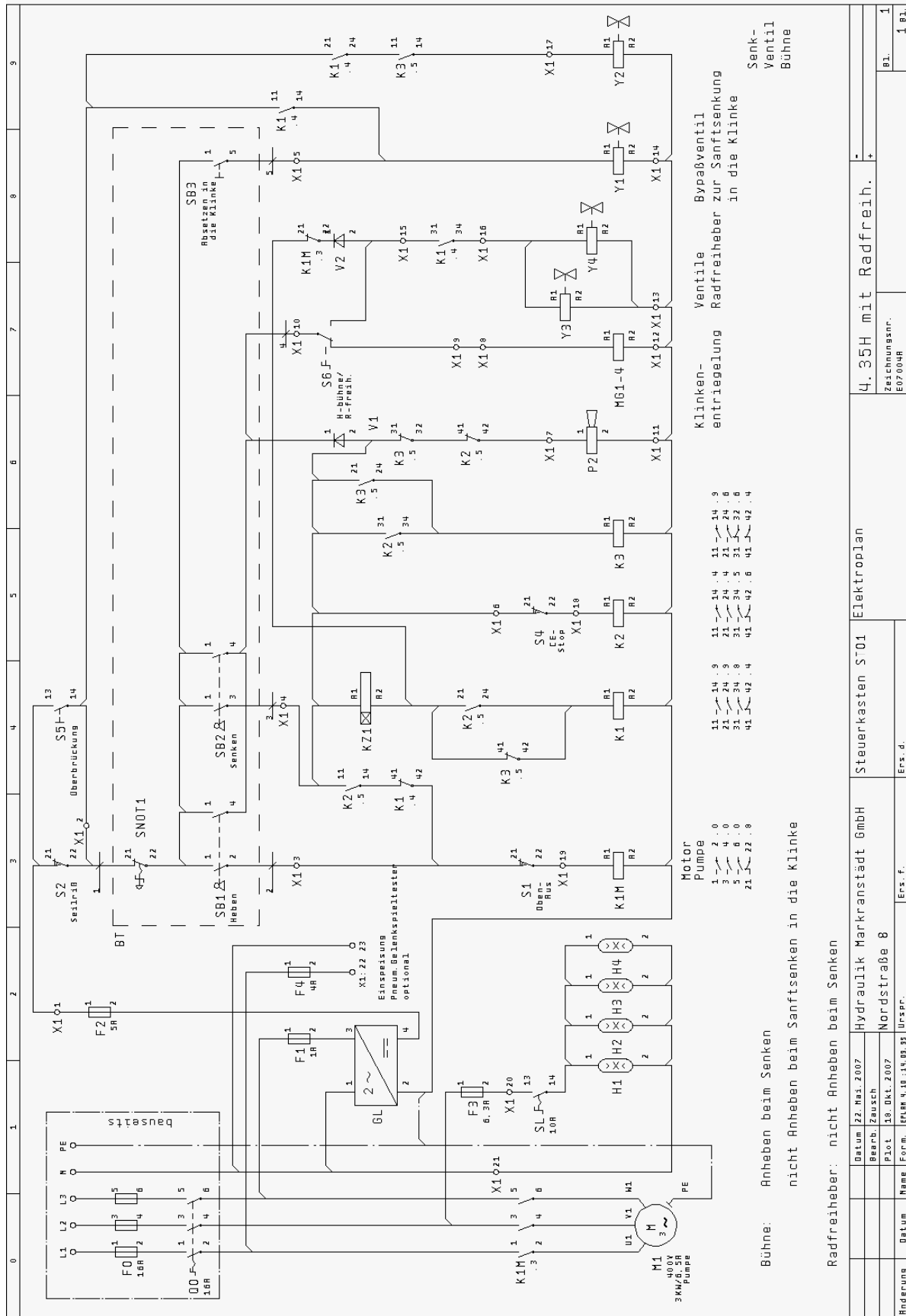

Electrical part list

Q0:	main switch 3-polig (fasten by customer)
M1:	motor 3~, 400 V, 3,0 kW
K1M:	up contactor
SB 1/2:	key switch "lifting/lowering"
SB3:	button soft lowering in the ratchets (main lift)
S1:	top limit switch (main lift)
S2:	limit switch „the rope is torn“
S4:	limit switch „CE-Stop“ the main lift is approx. 200 mm over the floor
S5:	override switch
S6:	switch (automotive lift or wheel free lift)
K1-K3:	Relais
P2:	loudspeaker
MG1:	electromagnetic (ratchet)
MG2:	electromagnetic (ratchet)
MG3:	electromagnetic (ratchet)
MG4:	electromagnetic (ratchet)
GL:	Transformer 230V/24V
GL:	rectifier
F1:	fuse 0,5A
F2:	fuse 5 A
F3:	fuse 10A
F4:	fuse 4A
Y1:	Bypassventil mit vorgeschalteter Blende für Sanftabsenkung in die Klinke
Y2:	valve (main lift)
Y3:	valve (wheel free lift)
Y4:	valve (wheel free lift)
KZ1:	time relais 1sec.
H1-H4:	lighting
SL:	lighting switch

3.9 Electrical diagram drawing with 3 x 230 V

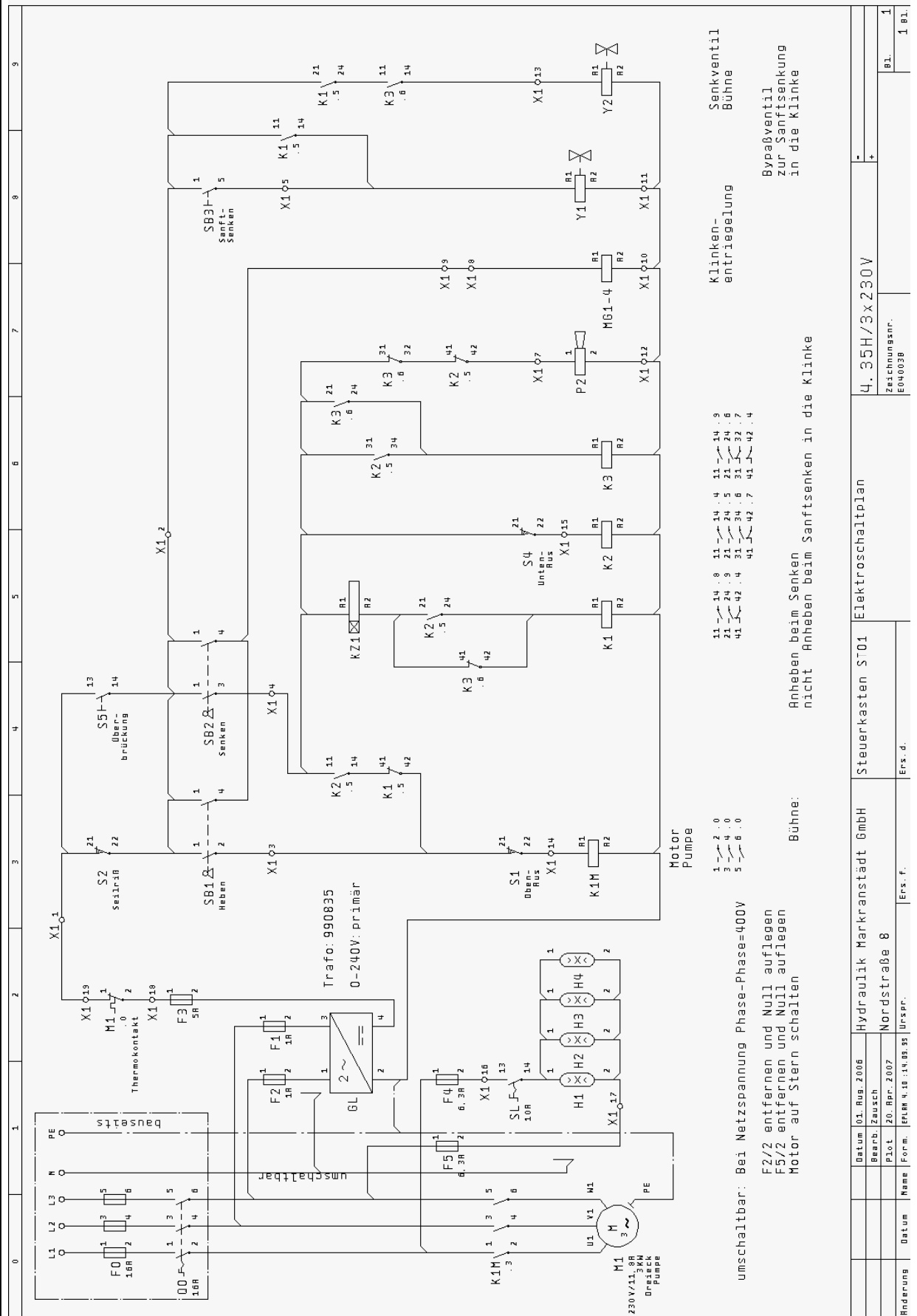

3.11 Connection-command (pictures)

Electrical wiring has to be executed by qualified personnel only!

Einspeisung / supply Bild 1

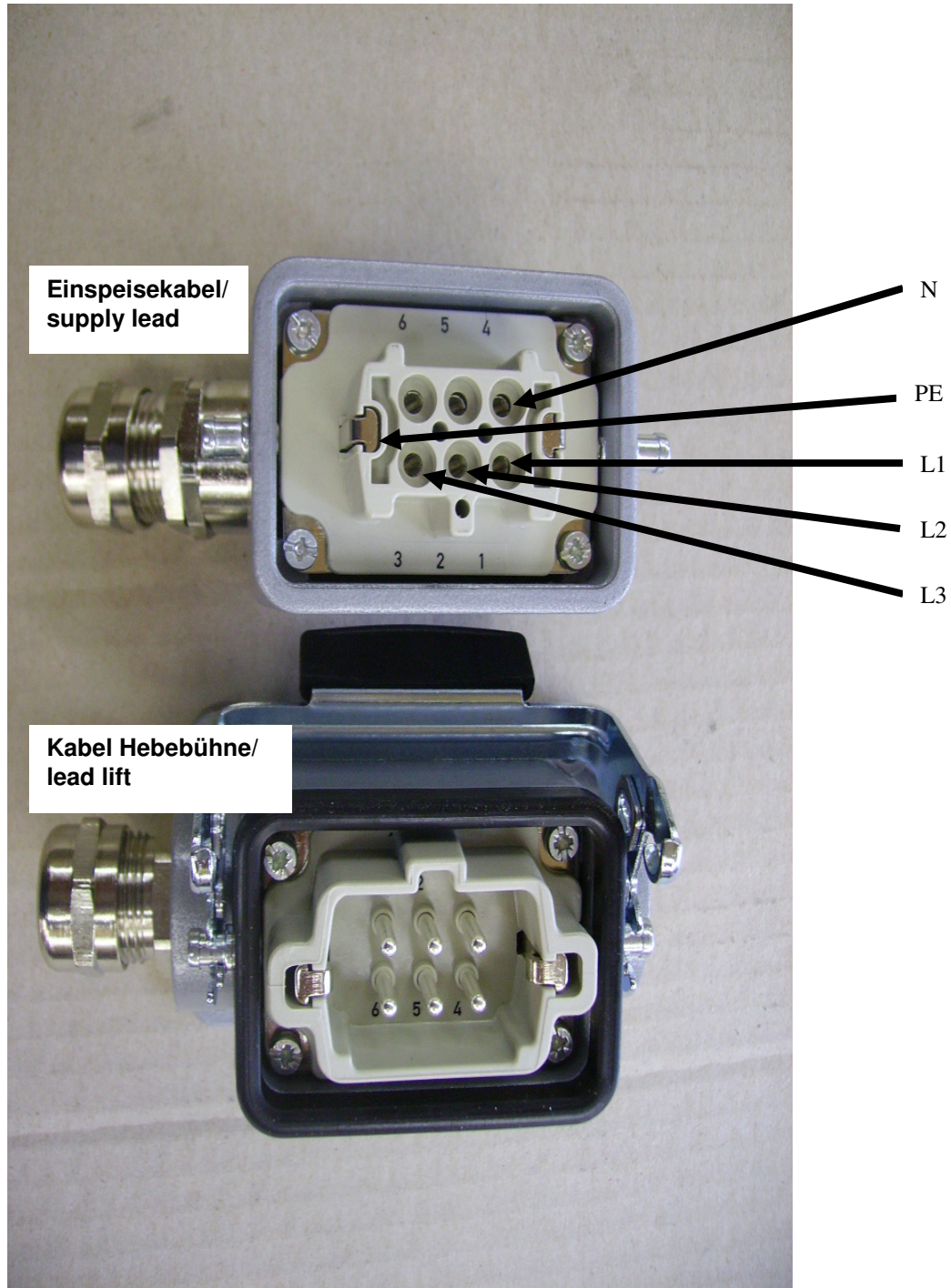

Einspeisung / supply Bild 2

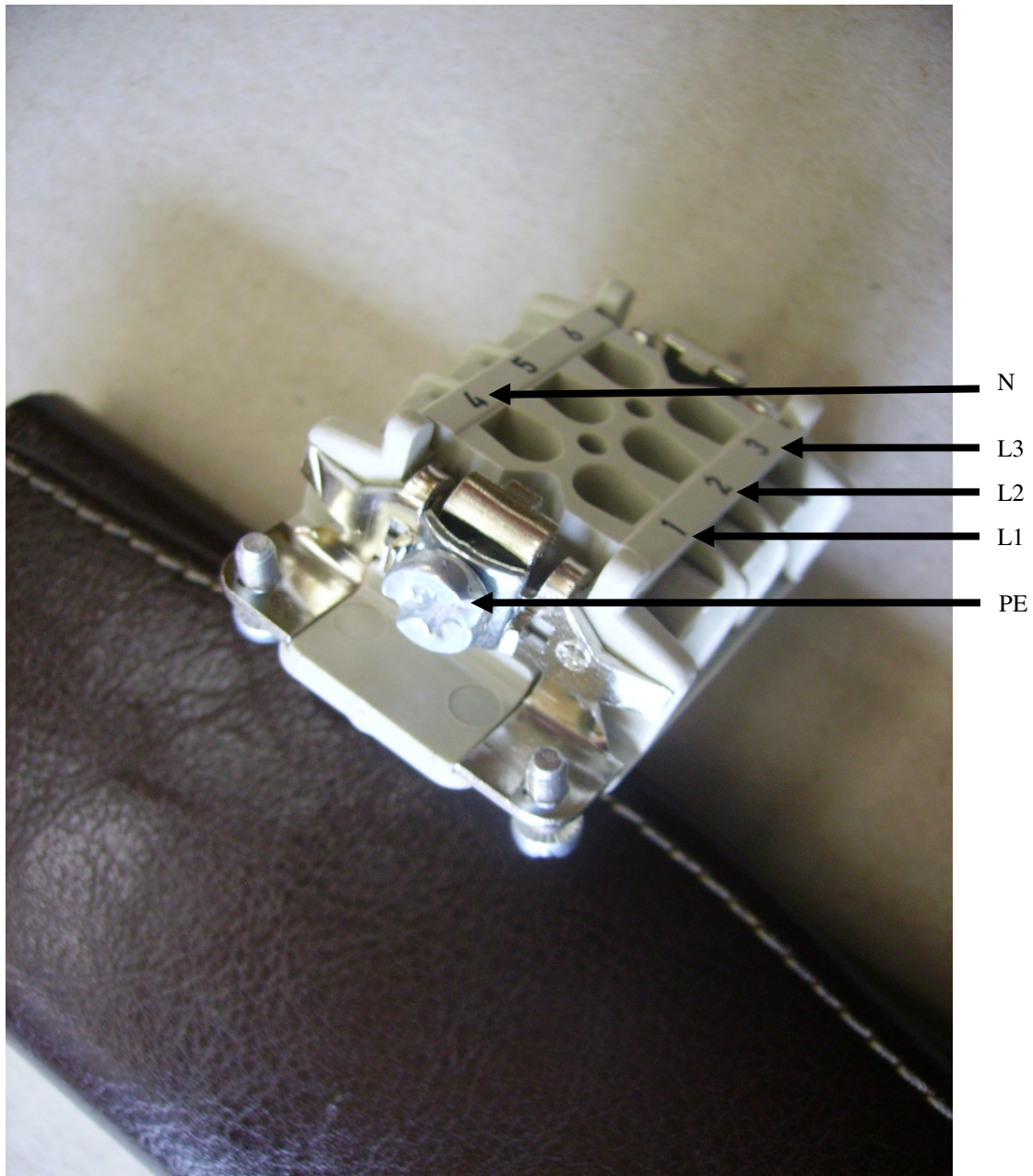

Einspeisung / supply Bild 3

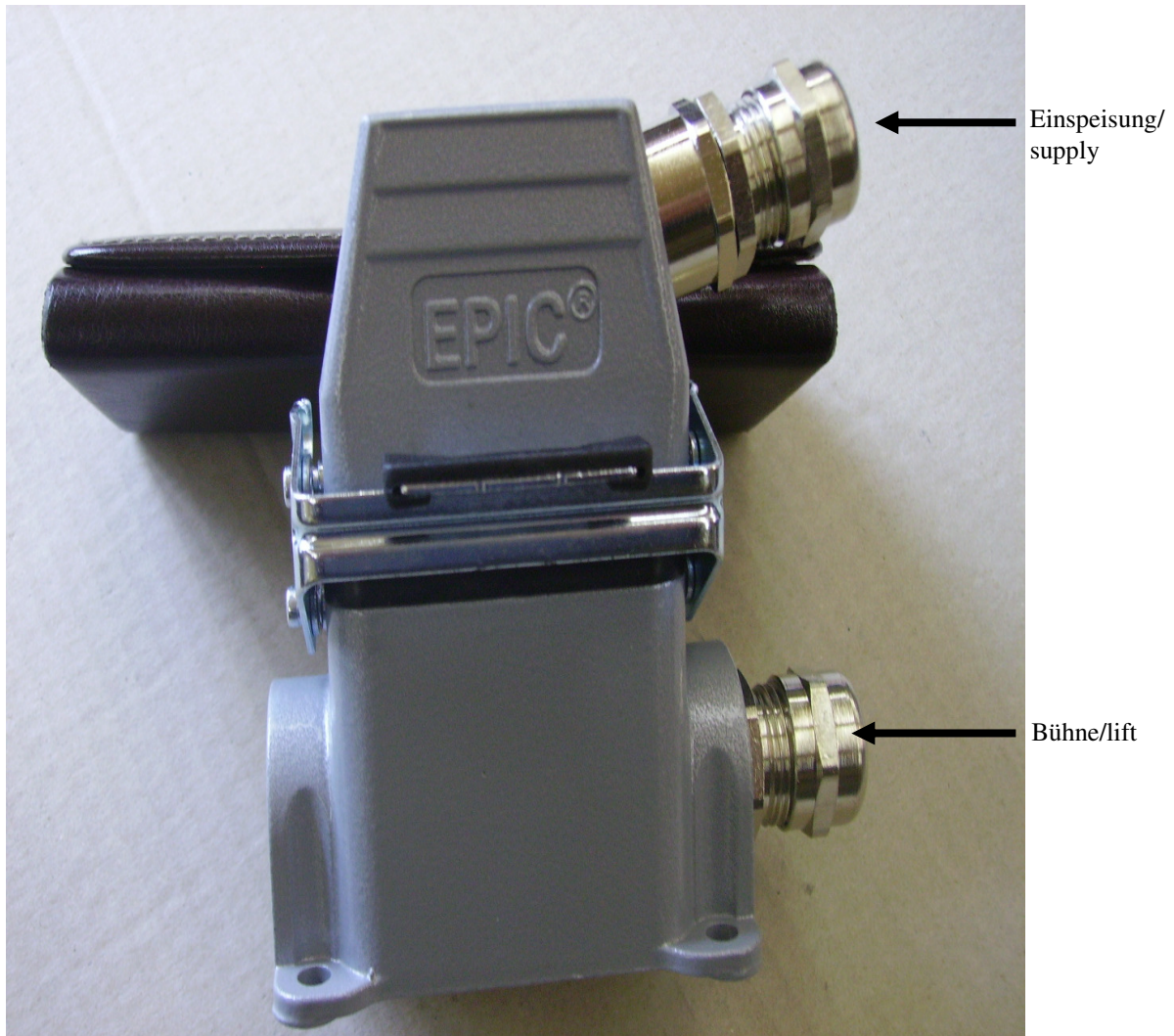

Oben-Aus-Schalter / top-off switch

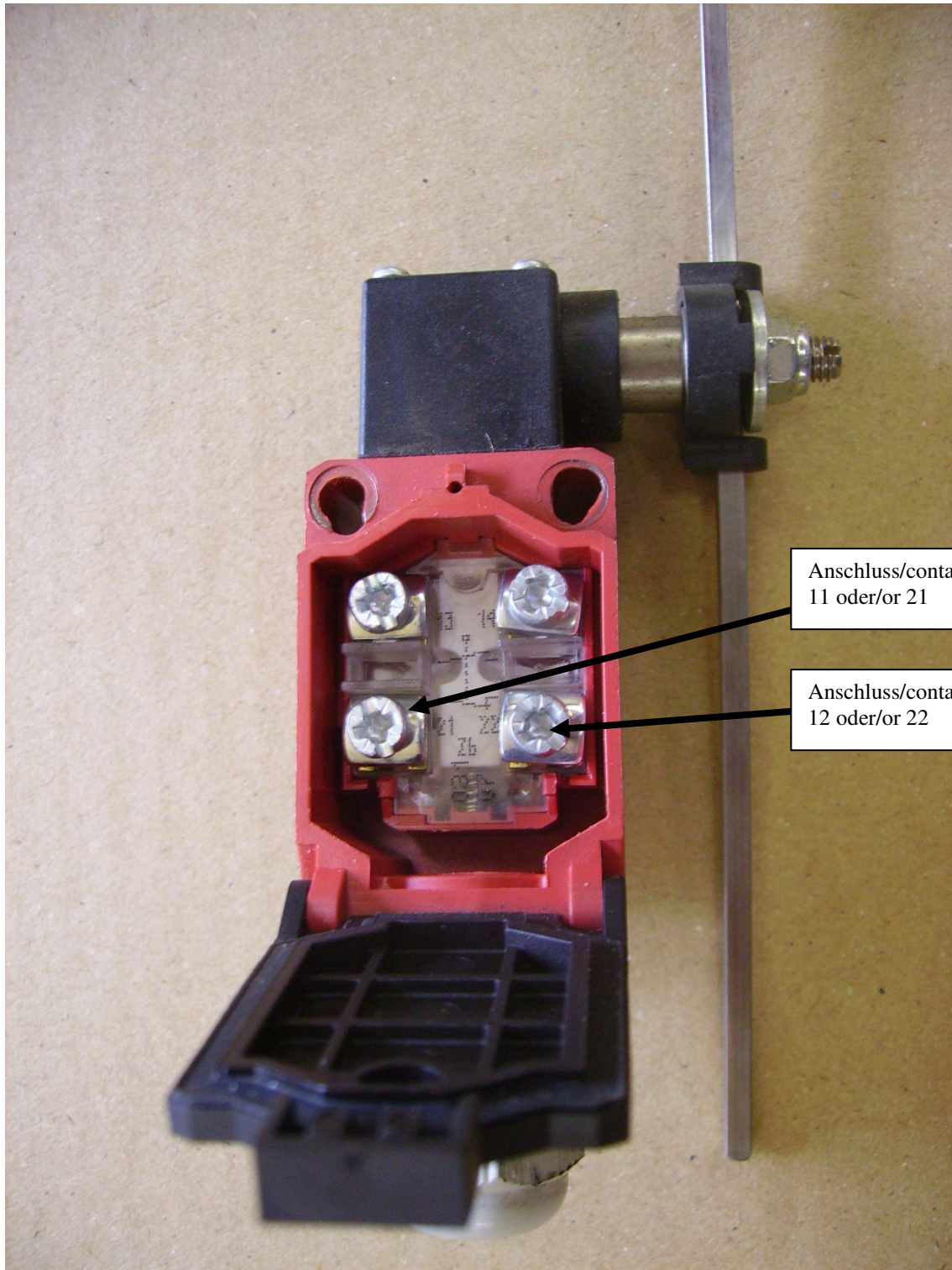

Anschluss/contact
11 oder/or 21

Anschluss/contact
12 oder/or 22

Schlüsselschalter / key switch

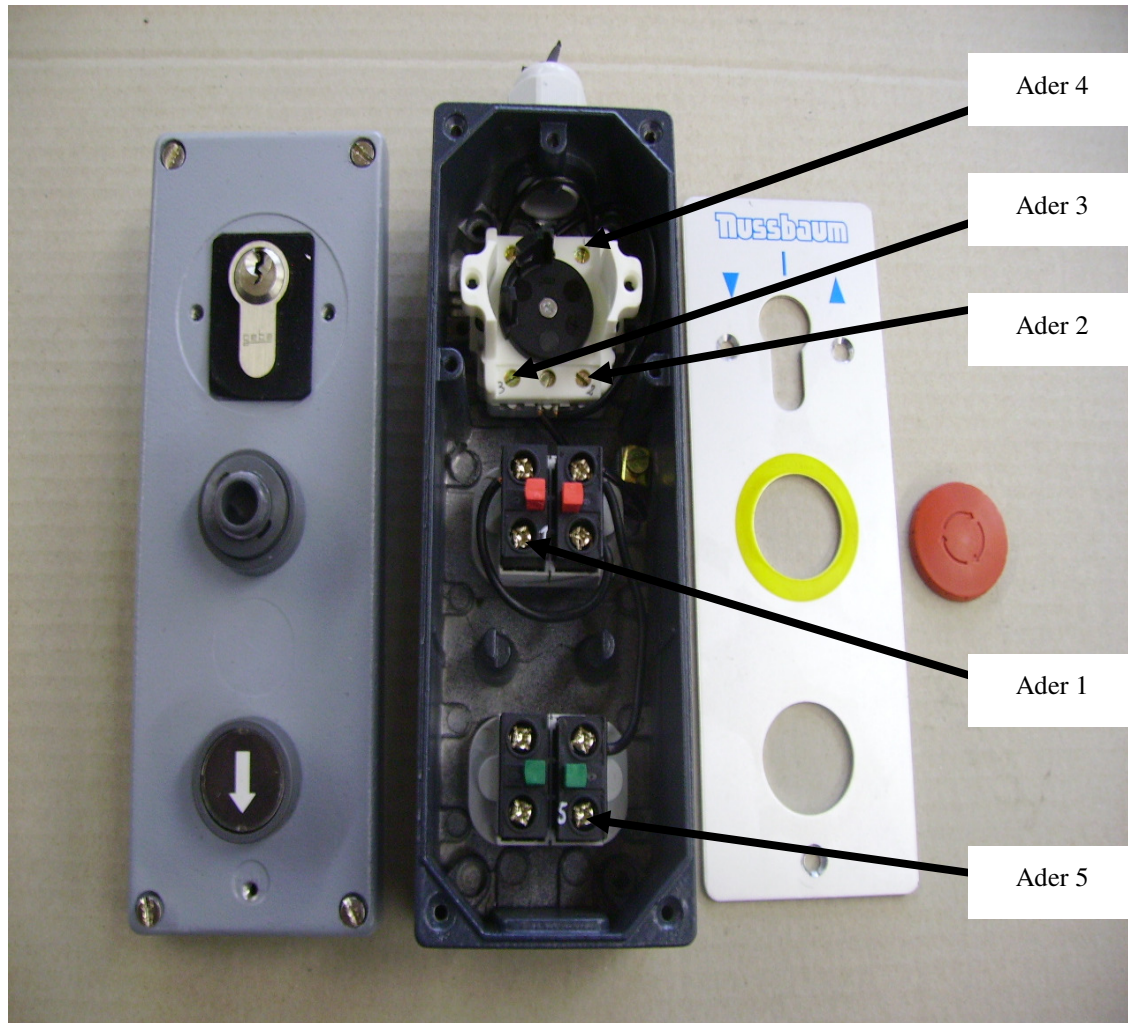

4. Safety regulations

If you use the lifting platforms, the German following regulations are to be considered:
BGG945: Examine of automotive-lifts; BGR500 Using automotive-lifts; (VBG14).

Especially the following regulations are very important:

- During working with the lift the operating instructions must be followed.
- The laden weight of the lifted vehicle mustn't be more than 4000 kg for automotive lift. The maximum load sharing is 2:1 in drive in direction or against drive in direction.
- Only trained personnel over the age of 18 years old are to operate this lift.
- During lifting or lowering the vehicle it must be observed from the operator.
- Position the polymer supports as described of the vehicle manufacturer under the vehicle.
- If necessary use the ramps.
- It's not allowed to stay under the lifted or lowered vehicle (except for the operator).
- It's not allowed to transport passengers on the lift or in the vehicle.
- It's not allowed to climb onto the lift or onto a lifted vehicle.
- The automotive lift must be checked from an expert after changes in construction or after repairing.
- It's not allowed to start with operations at the lift before the main switch is switched off.
- It's not allowed to install the standard-automotive lift in hazardous location.
- Keep the key on a safe place, if you don not work with the lift.

5. Operating instructions



***The Safety Regulations must be observed during working with the automotive lift.
Read the safety regulations in chapter 4 carefully before working with the lift!***

5.1 Lifting the vehicle with automotive lift

- Drive vehicle over the lift, longitudinal axes on line of the lift.



Each wheel must stand completely on the rail, otherwise the vehicle might fall down.

- Safe the vehicle against rolling away, switch into gear.
- Check the dangerous places of the lift and be sure that there are no objects or people in the immediate area of the lift or on the lift.
- Put the lever on the rail on position "main lift"
- Turn the key on the position "▲".
- Raise the vehicle on the working height. Observe the complete process.

Pic.1 key switch

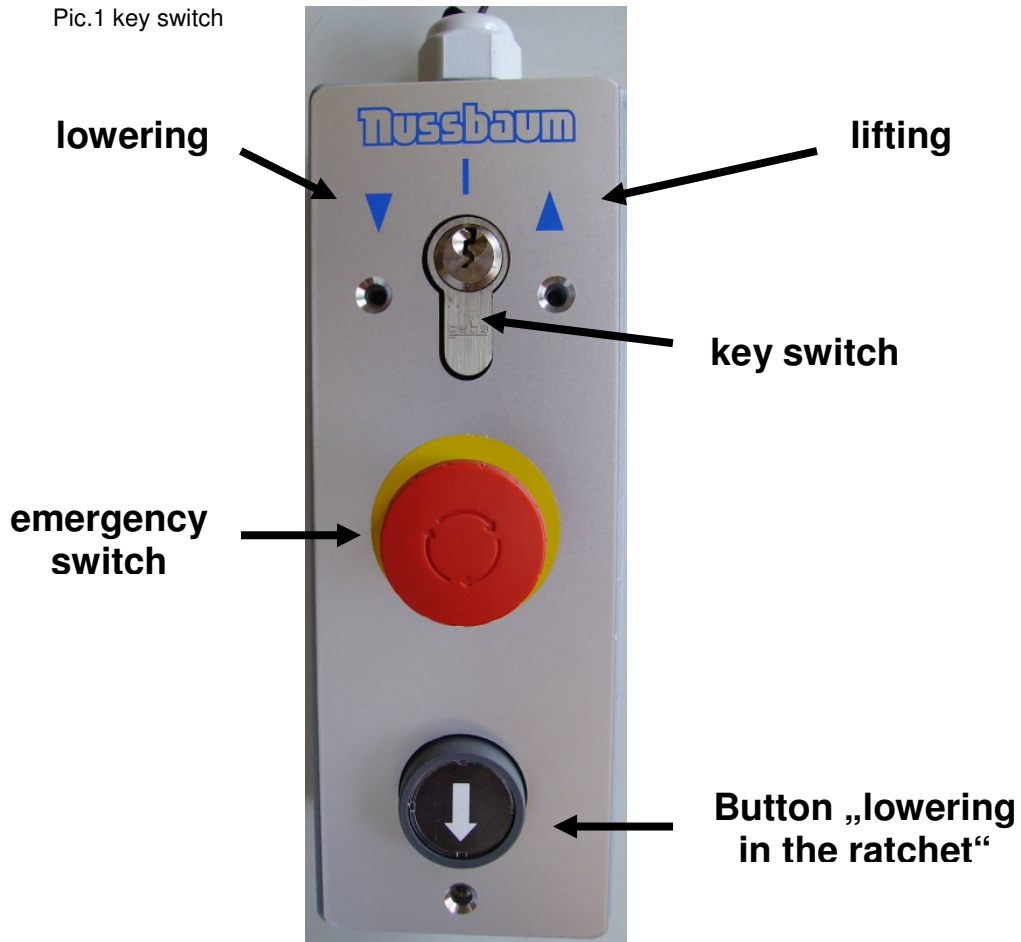

5.2 Lowering the vehicle with the automotive lift

- Check the dangerous places of the lift and be sure that there are no objects or people in the immediate area of the lift or on the lift.
- Turn the key on the position "▼". The lift is short lifting and then starts the lowering.
- Lower the lift on the working height or on the lowest position. Observe the complete process.



Comment!

If the main lift is on a height of approx. 200 mm over the floor, the lift stopped the lowering. Check the dangerous place of the lift and be sure that there are no objects or people in the immediate area of the lift or on the lift. Turn the key in the middle position and after in position "▽". You hear an acoustic warn signal until the lift is in the lowest position.

- If the lift is in the lowest position drive the vehicle from the lift.

5.3 Lowering the automotive lift in the ratchet strip (wheel alignment)

- Before the first wheel alignment, loose only the nuts (M8) from the sliding plates under the rails.
- The sliding plates must be locked when using the automotive lift.
- Position the vehicle on the lift.
- Unlock the sliding plates.
- Position the turn tables under the wheel. If necessary use the Jack.
- Check the dangerous places of the lift and be sure that there are no objects or people in the immediate area of the lift or on the lift.
- Press the button "lowering in the ratchet" at the key switch. (see pic.1)
- Press the button so long until all four ratchets are locked.

5.4 Raise the automotive lift out of the ratchet strip

- Check the dangerous places of the lift and be sure that there are no objects or people in the immediate area of the lift or on the lift.
- Turn the key on the position "Δ" until the ratchets are free.

5.5 Function of the Override switch



Press only the override switch in case the ropes are flabby.

This is possible if the lift lowered on a obstacle or the lifts is in the ratchets. This is not a malfunction of the lift. It's a additional safety device.

Do not use the override switch in the normal function of the automotive lift, otherwise the safety function are out of function.

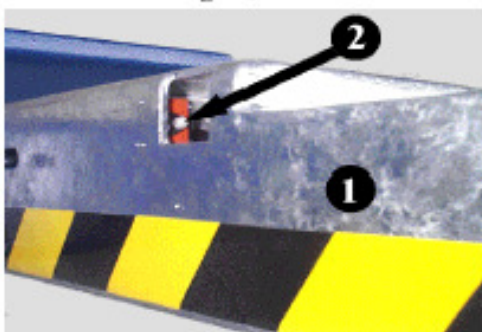

Pic 2:
Override switch at the rail
1 rail
2 press button

(The position of the switch can be vary depending upon type)

6. Troubleshooting

If the lift does not work properly, the reason for this might be quite simple. Please check the lift for the potential reasons mentioned on the following pages. If the cause of trouble cannot be found, please call the technical service.



Repairs at the lifts security devices, repairs and examinations of the electrical fittings may only be performed by specialists.

Problem: Motor does not start!

- Potential causes:
- Main switch is not engaged.
 - The feed line is cut.
 - Power failure.
 - Thermofuse in the motor is activ (let it cool down approx. 10 min).
 - ropes are flabby and the limit switch is pressed.

Problem: Motor starts, lift does not raise!

- Potential causes:
- The vehicle is too heavy
 - Level of the oil is too low.
 - The emergency lowering screws are not closed.
 - The hydraulic hoses are dirty.
 - Cylinder is defective

Problem: The lift does not lowered!

- Potential causes:
- The lift is standing on a obstacle.
 - The hydraulic valve is defective.
 - The key switch is not active.
 - The lift is in the ratchet.

6.1 Driving on an obstacle with the main lift

If the lift is running onto an obstacle during the lowering, it stops mechanically. In this case press the override switch (see pic 2.) at the rail and turn the key on position "Δ" simultaneous until the obstacle can be removed.

6.2 Emergency lowering in case of power failure or defective valve

In this case of power failure or defective valve, the hydraulic valves of the lift will not open any more. Therefore the lift can not be lowered. In this case there is the possibility to open the hydraulic valve manually and to lower the lift into lowest position, so the vehicle can be driven off.



The emergency lowering can only be performed by persons instructed to use the lift. Please refer to the regulation „Lowering the vehicle“.



Every kind of external leakage must be removed. This is necessary particular before emergency lowering.



The emergency lowering must be carried in this order. Otherwise a malfunction can lead it to damages or lead to danger for body and lives.

In this case of power failure the emergency lowering can only be performed if the ratchets are not engaged.

In case of defective valve the lift can be lifted a little. So it is possible to pull back the ratchets manually.

- Pull back the ratchets manually and lay a suitable support (wedge) between the ratchet strip and the ratchet. Or fix the ratchet with the help of a wire. This step should be taken at all four ratchets.
- Loose the lock nut (red nut).
- Control the dangerous places of the lift and be sure that there are no objects or people in the immediate area of the lift or on the lift.
- Loose the emergency screw (set screw) one turn to start lowering.
- The emergency lowering starts. The lowering speed can be influence with this emergency lowering screw.
- Lower the lift in the lowest position.
- Observe the complete process.
- Fasten the emergency lowering screw and the lock nut, if the lift is in the lowest position.

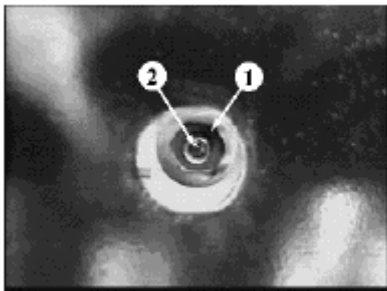

Pic 3: Emergency lowering screw at the side of the rail

- 1 lock nut
- 2 emergency lowering screw



After finishing the emergency lowering, close the emergency screw and fasten the lock nut. Otherwise a malfunction of the lift can occur.

- Remove the support (wedge) or the wire of the ratchets.



To guarantee the safe running of the lift, the supports must be removed.

- Do not work with the lift until the faulty parts are exchanged. Call the service-partner.



Switch off the main switch and lock it. Do not work with the lift until the faulty parts are exchanged.

7. Maintenance

A regular service has to be performed every three months by the lifts operator according to the following schedule. If the lift is in continuous operation or dirty environment, the maintenance rate has to be increased.

During daily operation the lift has to be watched carefully for its correct function.

In case of any malfunction the technical service of the retailer has to be informed.

7.1 Inspection and Maintenance

ATT lifts have been designed and manufactured for longevity and safe operation. Proper installation and operation, regular inspections and ensuing preventative maintenance by authorized personnel and product care, are the key to operators safety, product reliability, low overall repair costs, qualified warranty claims and finally, longevity of the lift. Our lifts are German TÜV and European CE certified and meet or surpass the safety standards of the countries in which we sell. European regulations for instance, oblige inspection by qualified personnel, every 12 months during the life span of the lift.

Whatever the regulations are in a given country, the following are the minimum, requirements regarding the maintenance of ATT lifts.

1. Product care. On an daily/weekly basis by lift operator

Always contact qualified service personnel whenever there is a safety issue. Check for anomalies at all times in particular after electrical power failure or flooding of the shop floor (check sealing of the canister of in-ground lifts). Execute equalization procedure of lifts with master/slave system (XX PH- and X Lifts). Check for leaky and kinked pipes and hoses. Clean the lift and the floor with a non-aggressive detergent. Prevent corrosion by oiling metallic parts or paint retouch. Check filters, grease/lubrication needs and air pressure. Check condition of lifting pads/polymer supports.

2. Inspection. At least once a year by qualified technician

- Safety related:**
- Check the proper functioning of all mechanical, electrical, hydraulic and pneumatic safety locking functions
 - Check for proper anchoring of the lift to the floor and floor cracks
 - Check for potential structural failures, in particular of welded parts
 - Check for bending or distortion of mechanical parts

Maintenance related:

- Check for hydraulic/air leaks and condition of pipes/hoses
- Check electrical connections, switches and fuses
- Check for wear of all bearings, hinge points and shafts
- Check condition of lifting pads
- Check for leakage to the in-ground lift canister
- Check for corrosion building

3. Preventative maintenance by qualified technician

- Replace **hydraulic oil** once every year. 10 litre , 32 cst.
- Replace **hydraulic hoses** at least once every 6 years
- Take proper **product care** as recommended in point 1
- Replace **safety related** parts whenever there is the slightest doubt
- Replace or repair worn or improper functioning **maintenance related** parts, before they break down. This avoids costly repairs at a later date

Inspection, repair and maintenance may be done by technicians from ATT, ATT's distributor or end-user. This personnel must be trained on the particular models of lift which they service. They must be able to make a judgment as to the repair or maintenance that needs to be done in order to ensure full safety, operational reliability and structural integrity during the life time of the lift. Proper maintenance records should be kept to back up possible warranty claims.

7.2 Cleaning of the automotive lift

A regular and appropriate maintenance served the preservation of the lift.

It can be a prerequisite for claims at possible corrosion.

The best protection for the lift is the regular cleaning of dirt of all manner.

- Including this:

- de-icing salt
- sand, pebble stone, natural soil
- industrial dust of all manner
- water ; also in connection with other environmental influences
- aggressive deposit of all manner
- constant humidity by insufficient ventilation

How often must the lift be cleaned ?

This is dependent on the use, of the working with the lift, of the cleanness of the workshop and location of the lift. The degree of the dirt is dependent on the season, of the weather conditions and the ventilation of the workshop.

Under bad circumstances it is necessary to clean the lift every week, but a cleaning every month can suffice.

Clean the lift and the floor with a non-aggressive and non-abrasive detergent. Use gentle detergent to clean the parts. Use an standard washing-up liquid and lukewarm water.

- Do not use for cleaning a steam jet cleaning.
- Remove all dirt careful with a sponge if necessary with a brush.
- Pay attention that are no remains of the washing-up liquids on the lift after cleaning.
- Do not use aggressive means for cleaning the workshop floor and the automotive lift.
- A permanent contact with every kind of liquid is forbidden. Do not use any high pressure device for cleaning the lift.

8. Security check

The security check is necessary to guarantee the safety of the lifting during use. It has to be performed in the following cases:

1. Before the initial operation, after the first installation
Use the form "First security check before initiation"
2. In regular intervals after the initial operation, at least annually.
Use the form "Regular security check at least annually"
3. Every time the construction of that particular lift has been changed.
Use the form "Extraordinary security check"



The first and the regular security check must be performed by a competent person. It is recommended to service the lift at this occasion.



After the construction of the lift has been changed (changing the lifting height or capacity for example) and after serious maintenance works (welding on carrying parts) an extraordinary security check must be performed by an expert.

This manual contains form with a schedule for the security checks. Please use the adequate form for the security checks. The form should remain in this manual after they have been filled out. In the following there is a short description about special safety devices.

9. Installation and Initiation

9.1 Regulations for the installation

- The installation of the lift is performed by trained technicians of the manufacturer or its distribution partner. If the operator can provide trained mechanics, he can install the lift by himself. The installation has to be done according to this regulation.
- The standard lift must not be installed in hazardous locations or washing areas.
- Before installation a sufficient foundation must be proved or constructed.
- An even installation place has to be provided. The foundations must be based in a frost resistance depth, both outside and indoors, where you must reckon with frost.
- An electrical supply (standard Version) 3~/N+PE, 400 V, 50 Hz has to be provided. The supply line must be protected with T16A (VDE0100 German regulation). The minimum diameter amounts to 2,5 mm².
- All cable ducts have to be equipped with protective coverings to prevent accidents.

9.2 Erection and doweling of the lift

It is necessary to dowel the columns at 4 points and to safe the lift against slipping. For this a concrete floor without reinforcement, thickness of 140 mm and quality C20/25 (B25) is needed. In case of doubt a test drill is necessary and a dowel is to put in. Afterwards the dowel is to fasten with the correct torque. If the necessary torque is to low or if there are cracks in the concrete floor, a foundation in accordance with the sheet "foundation plan" is to erected. As well it must be paid attention that the installation place is even to guarantee a horizontal erection of the lift.

- Put runways on two erection trestles at installation place, pay attention of exactly difference between the runways (refer to data sheet).
- Position the crossbeams on the face of the runways, and put the plugs together.
- Mount the ropes (see pic. 5).
- Position the columns at the ends of the crossbeams.
- Line up operating column (with bubble level) and drill holes for dowel-fixing through four bore-holes of base plates. Clean bore-holes with pressure air. Put in the safety dowels with washers in borings.
- Take carrying ropes through columns to upper side and fix them in the head plate
- Check the position of the lift and the position of the operating columns again.
- Bore holes to fix the dowels through the borings of the base plates. Clean holes with

pressure air. Put in safety dowels with washers in borings.

The manufacturer demands LIEBIG safety dowels or equal dowels of another manufacturer (with allowance) but observe their regulations! Before doweling check concrete floor with quality C20/25 if the concrete floor goes to the top edge of the floor. In this case the dowels have to be chosen according to picture 8. If the ground is covered with floor tiles, the dowels have to be chosen according to picture 9.

- Tighten the dowels a little.
- Connect power supply:
Pull the **electrical cable (5x 1,5 cable)** from the hydraulic-unit (under the rail) via the crossbeam and through the energy chain to the top of the operating column.
Pull the **control line (7x1 cable)**. Connect the operating unit as well via crossbeam through the energy chain to the top of the operating column and afterwards from the topside through the cable channel to the key switch.
- Tighten the screws at the crossbeam.
- Fill in the hydraulic-oil, approx. 10 litre.
- Raise the lift a little with the key switch and push the override switch (at the side of the rail) simultaneous.
- Remove the erection trestles.
- Mount the safety ratchets in the column - if necessary lower the lift.
- Lower the lift in the ratchet (read chapter "lowering in the ratchet)
- Line up the columns with a help of a bubble level again.
- Tighten the dowels with the dynamometric key
Each dowel must be tightened with the demanded torque. Otherwise the normal function of the lift can not guaranteed.
Observe the regulations of the other dowel-manufacturer.
- Mount the ramps and the loading ramp.
- Adjust the sliding guidance at the crossbeam (approx. 4-5 mm movement between the sliding guidance and the column).
- Adjust regular height of the rails at all of the four columns by moving the nuts, which fix the carrying ropes in the head plate. For demanded measuring accuracy of all important vehicle manufacturer it is necessary to install the lift very exactly and to line it up. For this to the following points should be paid attention.
- Lift the automotive lift to eye level and lower it down in the ratchet (refer to operating instructions).
- Position each of the measuring scales on the traverse and check the level of the two rails.

Tolerance handicap of Daimler Chrysler:

- in front left/right Difference \square 1mm
- in front left / behind right Difference \square 2mm
- in front left / behind right Difference \square 2mm
- in front left / behind right Difference \square 2mm
- in front left / right Difference \square 1mm
- Adjust the rails with the screws of the ratchet-rod (on the "head-plate" at the top of the column.
- Raise and lower the lift several times with load. Check the torque of the dowels and check the hydraulic parts for tightness.
- Mount the covers.

pic.5

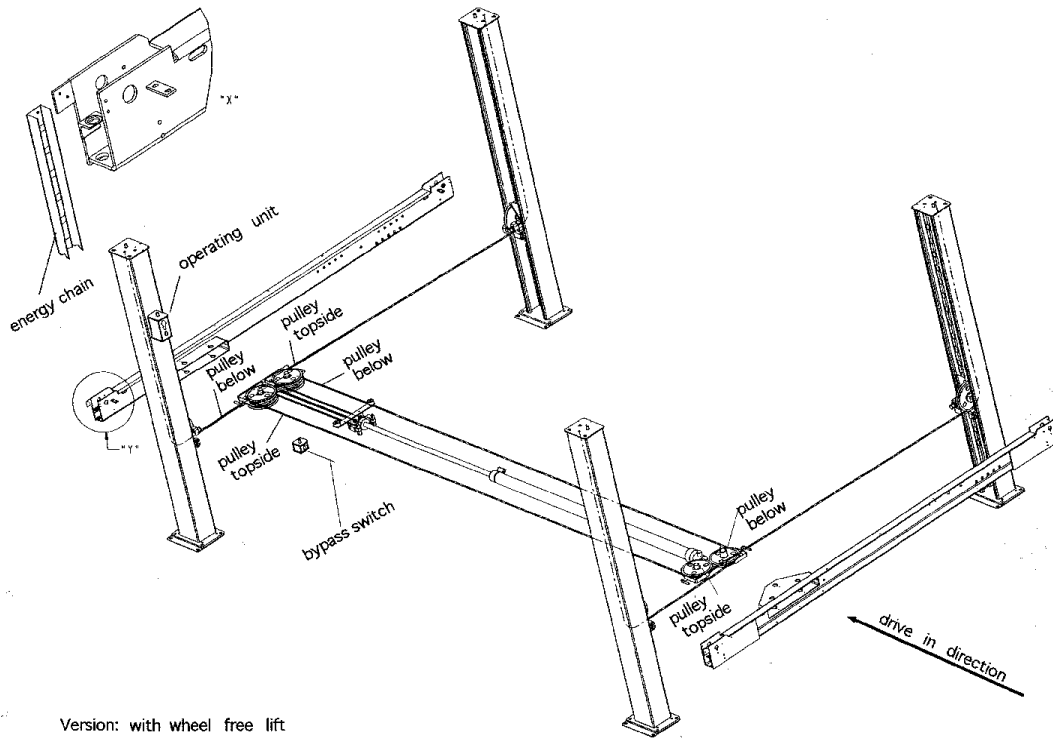
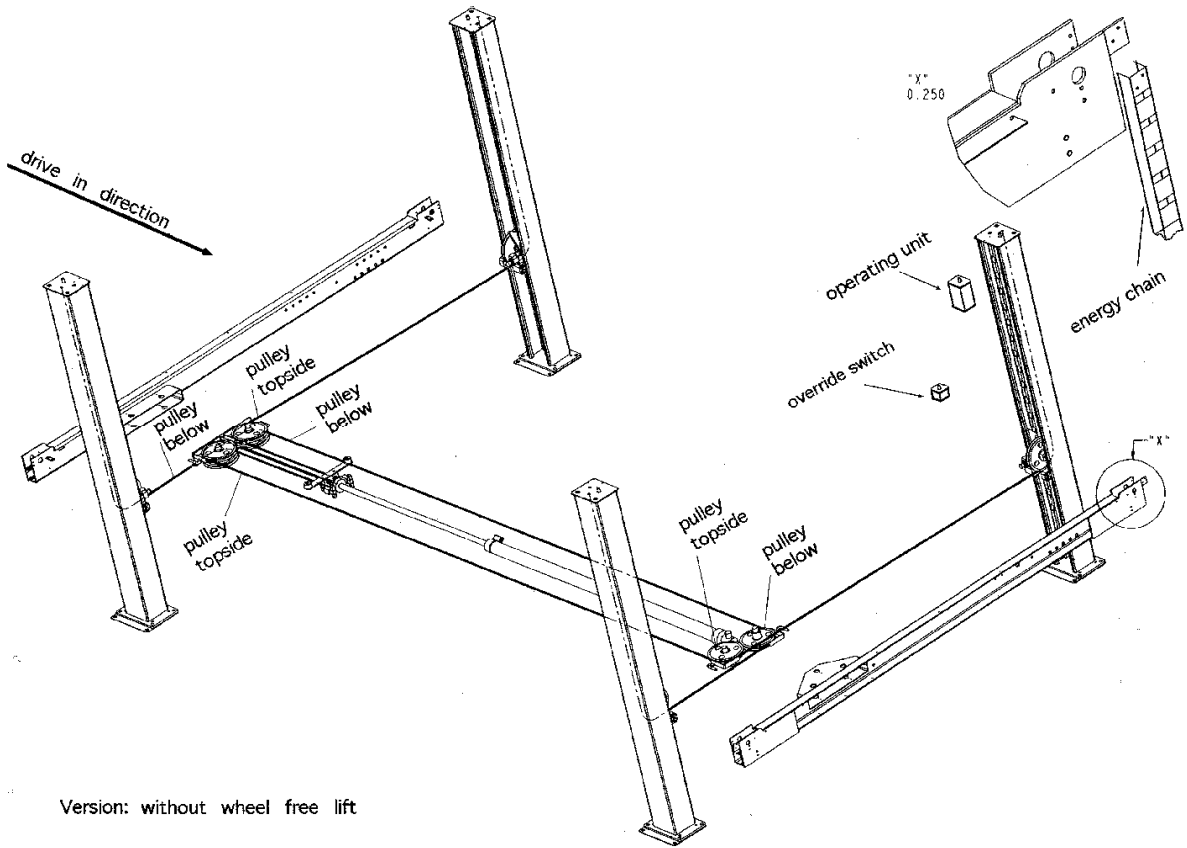

pic.6

9.3 Adjusting the rail

The standard measure between the rails is 850 mm. It is possible to adjust the rails +/-100 mm (see the datasheet). Lower the lift in the ratchets until there is no tractive power on the ropes .

- Lower the main lift in the ratchet.
- Remove the ramp and the roll-off of the rail (only at the adjustable rail)
- Remove both cover of the crossbeam.
- Remove the screws and if necessary position supports under the rail.
- Adjust the rail.
- Tighten the screw.
- Mount the cover.
- Mount the ramp and the roll-off safety.
- Raise the lift out of the ratchets.

9.4 Initiation



Before the initiation a security check must be performed. therefore use form: First security check.

If the lift is installed by a competent person, he will perform this security check. If the operator installs the lift by himself, he has to instruct a competent person to perform the security check.

The competent confirms the faultless function of the lift in the installation record and form for the security check and allows the lift to be used.



Please send the filled installation record to the manufacturer after installation.

9.5 Changing the installation place

If the place of installation shall be changed, the new place has to be prepared in according to the regulations of the first installation. The changing should be performed in accordance with the following points:

- Position two erection trestles under the rails.
- Lower the lift until the rails are lay on the erection trestles.
- Disconnect electrical current supply from the lift.
- Loose the fixing nuts of the carrying ropes on the head plate and remove them.
- Loose the crossbeams from the rails and pull carrying ropes out of the crossbeams.
- Loose the plugs.
- Loose the dowels.
- Transport lift to new installation place.
- Install lift in accordance with chapter "Installation and Initiation" of the lift.



Use new dowels, the used dowels can not be used anymore.



A security check must be performed before re initiation by a competent person. Use form "Regular security check".

9.6 Position of the columns

pic. 7

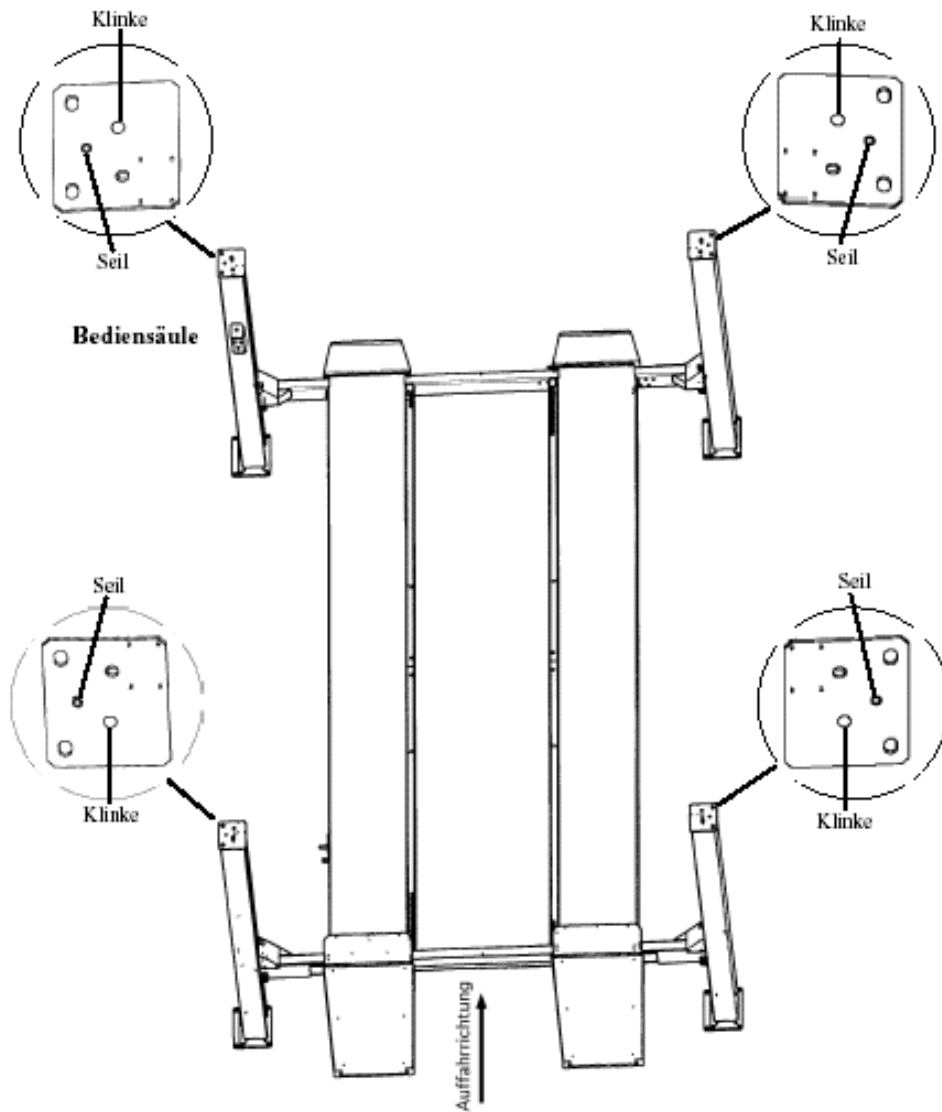

Klinke = ratchet

Seil = rope

Auffahrrichtung = drive on direction

Pic. 8 : choice of the dowel length without floor pavement or tile surface

BM10-15

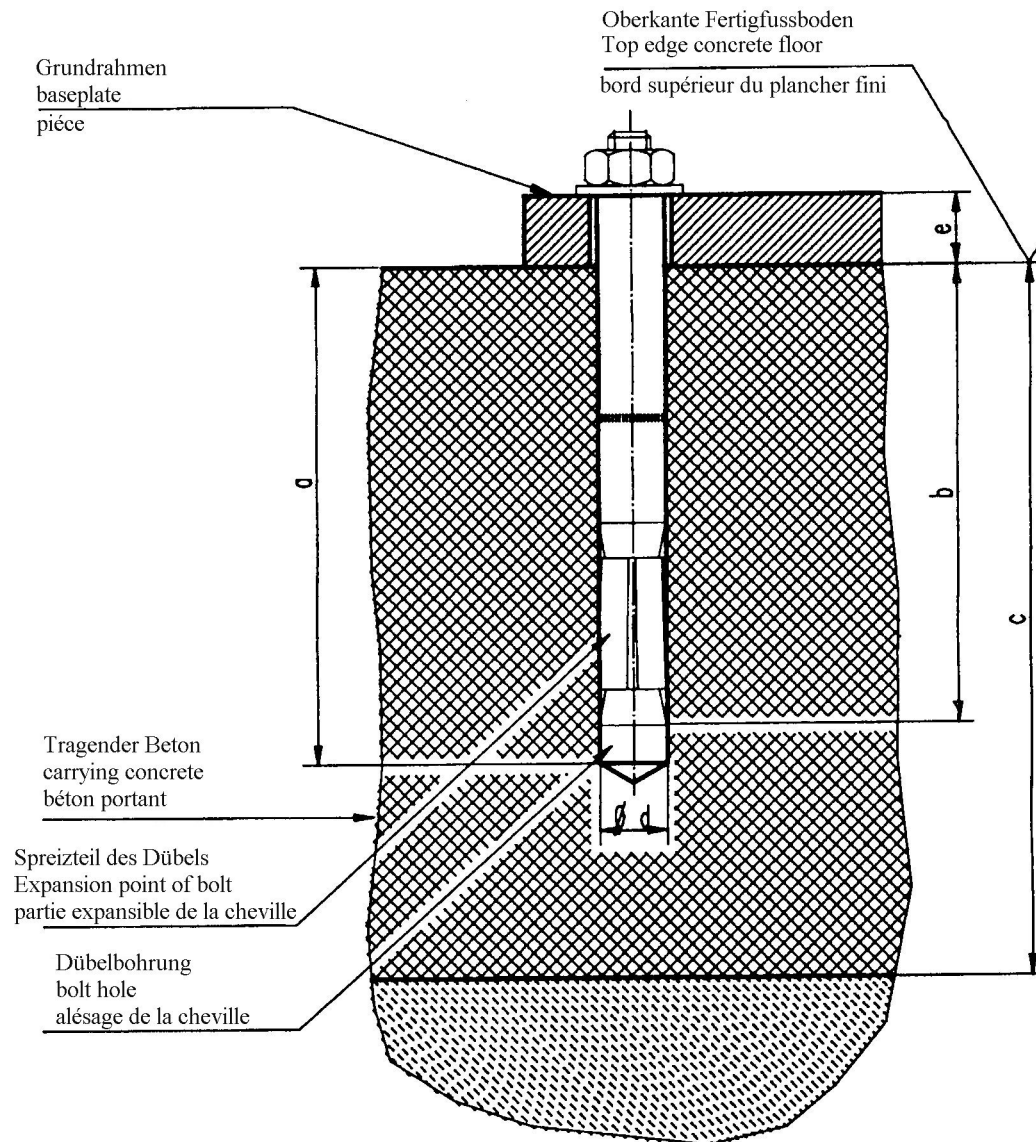

Liebig-dowels

Dowel type	BM10-/70/40
Drilling depth	a 85
Min. anchorage depth	b 70
Thickness of concrete	c min.140(*)
Diameter of bore	d 15
Thickness of the lift-pieces	e 0-40
Number of dowels	X
Starting torque	40

(*) minimum thickness of concrete by using the mentioned dowels. Otherwise, observe the regulation of the foundation plan.

You can use equivalent dowels from another dowel manufacturer (with license) but observe their regulation.

Pic 9: choice of the dowel length with floor pavement or tile surface

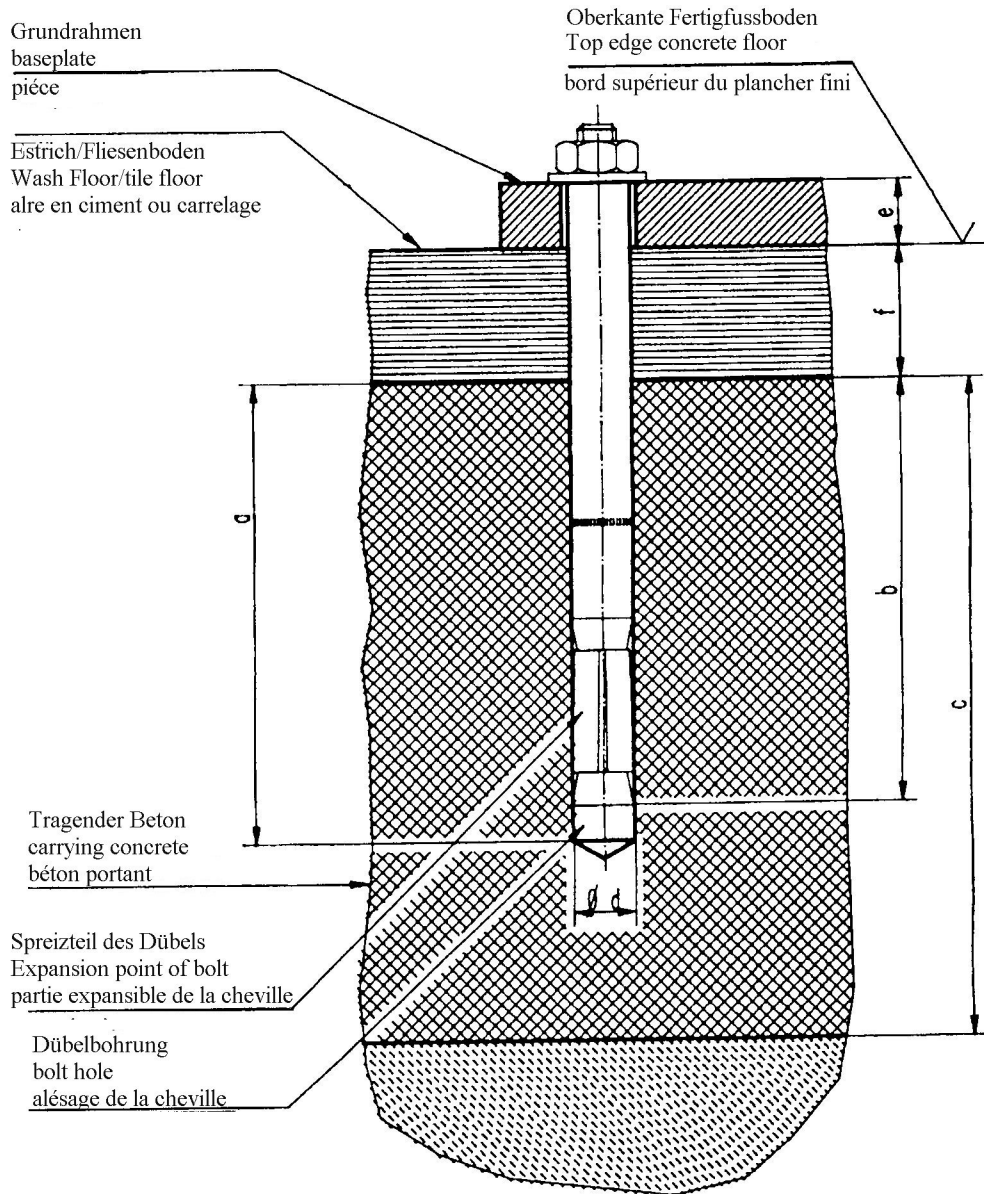

Liebig-dowels

Dowel type		BM10-15/70/65	BM10-15/0/100	BM10-15/70/140
Drilling depth	a	85	85	85
Min. anchorage depth	b	70	70	70
Thickness of concrete	c	min.140(*)	min.140(*)	min.140(*)
Diameter of bore	d	15	15	15
Thickness of the lift-pieces	e	40-65	65-100	100-140
Number of dowels		x	x	x
Starting torque		40 Nm	40Nm	40Nm

(*) minimum thickness of concrete by using the mentioned dowels. Otherwise, observe the regulation of the foundation plan.

You can use equivalent dowels from another dowel manufacturer (with license) but observe their regulation.

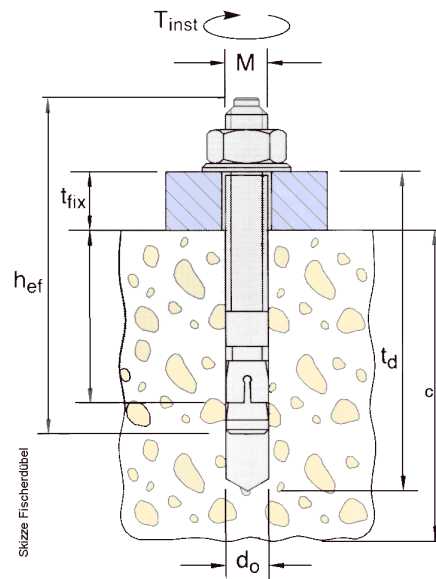

Skizze Fischerdübel

Änderungen vorbehalten!
subject to alterations!
sous réserve des modifications!

fischer-Dübel /dowels		Jumbo ^b , Sprinter ^b , 4.32H ^e -4.300H ^e , 1.25 SH-1.35SH ^a , 2.30 TLS ^a , 2.35 TS/TSA/TSK ^a , 2.32TSAP ^a , 2.35TSAPH ^a ,	2.25SL ^a , 2.32SL ^a -2.35 SL ^a , SPL ^b /Power-Lift ^b , 1.20 SE ^b UNI-LIFT 3500 NT/CLT ^d , 2.32TTL ^a	HDL5000 ^c , HDL6500 ^c , 250SE ^f ,
Dübel typ of dowel type de cheville		FH 15/50 B	FH 18 x 100/100 B	FH 24/100 B
Bohrtiefe drilling depth Profondeur de l'alsage	t _d	145	230	255
Mindestverankerungstiefe min.anchorage depth Profondeur minimale d'ancrage	h _{ef}	70	100	125
Betonstärke thickness of concrete Epaisseur du béton	c	siehe den aktuellen Fundamentplan see current foundation-diagram drawing vois le plan de fondation actuel		
Bohrerdurchmesser diameter of bore Diamètre de l'alsage	d _o	15	18	24
Bauteildicke thickness of the lift-piece Epaisseur de la pièce	t _{fix}	0-50	0-100	0-100
Anzugsdrehmoment Nm turning moment moment d'une force	M _d	40	80	120
Stückzahl piece number nombre des pièces	a	4		
	b	8		
	c	10		
	d	12		
	e	16		
	f	20		

Montage

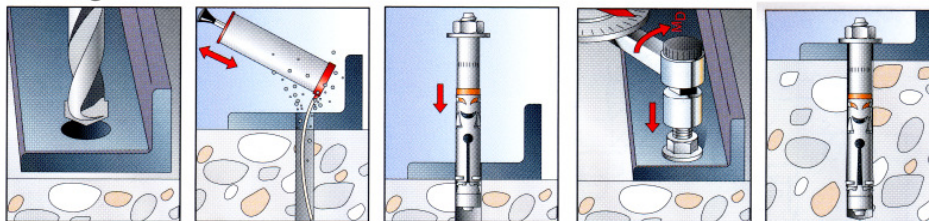

Es können auch gleichwertige Sicherheitsdübel anderer Hersteller (mit Zulassung) unter Beachtung deren Bestimmungen verwendet werden.
It is possible to use equivalent safety-dowels (with license) of other manufacturer but observe their regulations.
Des chevilles des autres marques (autorisées) peuvent aussi être choisies en respectant les directives du fabricant.

First security check before installation



Filling out and leave in this manual

Serial-no.: _____

kind of check	all right	defect missing	veri- fication	remark
Type plate.....	<input type="checkbox"/>	<input type="checkbox"/>	<input type="checkbox"/>
Short operating instruction.....	<input type="checkbox"/>	<input type="checkbox"/>	<input type="checkbox"/>
Warning designation.....	<input type="checkbox"/>	<input type="checkbox"/>	<input type="checkbox"/>
Sticker max. capacity.....	<input type="checkbox"/>	<input type="checkbox"/>	<input type="checkbox"/>
Designation lifting/lowering.....	<input type="checkbox"/>	<input type="checkbox"/>	<input type="checkbox"/>
Detailed operating instruction.....	<input type="checkbox"/>	<input type="checkbox"/>	<input type="checkbox"/>
Function key switch.....	<input type="checkbox"/>	<input type="checkbox"/>	<input type="checkbox"/>
Condition bolts and bearings.....	<input type="checkbox"/>	<input type="checkbox"/>	<input type="checkbox"/>
Function limit switch.....	<input type="checkbox"/>	<input type="checkbox"/>	<input type="checkbox"/>
Condition/Function Ramps.....	<input type="checkbox"/>	<input type="checkbox"/>	<input type="checkbox"/>
Condition automotive lift.....	<input type="checkbox"/>	<input type="checkbox"/>	<input type="checkbox"/>
Securing of bolts.....	<input type="checkbox"/>	<input type="checkbox"/>	<input type="checkbox"/>
Condition welding.....	<input type="checkbox"/>	<input type="checkbox"/>	<input type="checkbox"/>
Function override switch.....	<input type="checkbox"/>	<input type="checkbox"/>	<input type="checkbox"/>
Construction (deformation, cracking)	<input type="checkbox"/>	<input type="checkbox"/>	<input type="checkbox"/>
Torque of the dowels	<input type="checkbox"/>	<input type="checkbox"/>	<input type="checkbox"/>
Fixed seat of the screws.....	<input type="checkbox"/>	<input type="checkbox"/>	<input type="checkbox"/>
Condition operating unit.....	<input type="checkbox"/>	<input type="checkbox"/>	<input type="checkbox"/>
Condition surface piston rod	<input type="checkbox"/>	<input type="checkbox"/>	<input type="checkbox"/>
Condition coverings.....	<input type="checkbox"/>	<input type="checkbox"/>	<input type="checkbox"/>
Condition electrical wires	<input type="checkbox"/>	<input type="checkbox"/>	<input type="checkbox"/>
Level of hydraulic oil	<input type="checkbox"/>	<input type="checkbox"/>	<input type="checkbox"/>
Closeness of the hydraulic system.....	<input type="checkbox"/>	<input type="checkbox"/>	<input type="checkbox"/>
Condition hydraulic hoses.....	<input type="checkbox"/>	<input type="checkbox"/>	<input type="checkbox"/>
Function test with vehicle.....	<input type="checkbox"/>	<input type="checkbox"/>	<input type="checkbox"/>
Function flabby switch	<input type="checkbox"/>	<input type="checkbox"/>	<input type="checkbox"/>
Function CE-STOP.....	<input type="checkbox"/>	<input type="checkbox"/>	<input type="checkbox"/>
Function/condition ratchets.....	<input type="checkbox"/>	<input type="checkbox"/>	<input type="checkbox"/>
Function/condition pulleys.....	<input type="checkbox"/>	<input type="checkbox"/>	<input type="checkbox"/>
Function/condition slide-guidance.....	<input type="checkbox"/>	<input type="checkbox"/>	<input type="checkbox"/>
Condition plugs.....	<input type="checkbox"/>	<input type="checkbox"/>	<input type="checkbox"/>

(mark here applicable, in case of verification mark in addition to the first mark!)

Security check carried out:.....

Carried out the company:.....

Name, address of the competent:.....

Result of the Check:

Initiation not permitted, verification necessary

Initiation possible, repair failures

until.....

No failings, Initiation possible

.....
signature of the expert

.....
signature of the operator

If failures must be repaired:

Failures repaired at:

.....signature of the operator

(Use another form for verification!)

Regular security check



Filling out and leave in this manual

Serial-no.: _____

kind of check	all right	defect missing	verification	remark
Type plate.....	<input type="checkbox"/>	<input type="checkbox"/>	<input type="checkbox"/>
Short operating instruction.....	<input type="checkbox"/>	<input type="checkbox"/>	<input type="checkbox"/>
Warning designation.....	<input type="checkbox"/>	<input type="checkbox"/>	<input type="checkbox"/>
Sticker max. capacity.....	<input type="checkbox"/>	<input type="checkbox"/>	<input type="checkbox"/>
Designation lifting/lowering.....	<input type="checkbox"/>	<input type="checkbox"/>	<input type="checkbox"/>
Detailed operating instruction.....	<input type="checkbox"/>	<input type="checkbox"/>	<input type="checkbox"/>
Function key switch.....	<input type="checkbox"/>	<input type="checkbox"/>	<input type="checkbox"/>
Condition bolts and bearings.....	<input type="checkbox"/>	<input type="checkbox"/>	<input type="checkbox"/>
Function limit switch.....	<input type="checkbox"/>	<input type="checkbox"/>	<input type="checkbox"/>
Condition/Function Ramps.....	<input type="checkbox"/>	<input type="checkbox"/>	<input type="checkbox"/>
Condition automotive lift.....	<input type="checkbox"/>	<input type="checkbox"/>	<input type="checkbox"/>
Securing of bolts.....	<input type="checkbox"/>	<input type="checkbox"/>	<input type="checkbox"/>
Condition welding.....	<input type="checkbox"/>	<input type="checkbox"/>	<input type="checkbox"/>
Function override switch.....	<input type="checkbox"/>	<input type="checkbox"/>	<input type="checkbox"/>
Construction (deformation, cracking)	<input type="checkbox"/>	<input type="checkbox"/>	<input type="checkbox"/>
Torque of the dowels	<input type="checkbox"/>	<input type="checkbox"/>	<input type="checkbox"/>
Fixed seat of the screws.....	<input type="checkbox"/>	<input type="checkbox"/>	<input type="checkbox"/>
Condition operating unit.....	<input type="checkbox"/>	<input type="checkbox"/>	<input type="checkbox"/>
Condition surface piston rod	<input type="checkbox"/>	<input type="checkbox"/>	<input type="checkbox"/>
Condition coverings.....	<input type="checkbox"/>	<input type="checkbox"/>	<input type="checkbox"/>
Condition electrical wires	<input type="checkbox"/>	<input type="checkbox"/>	<input type="checkbox"/>
Level of hydraulic oil	<input type="checkbox"/>	<input type="checkbox"/>	<input type="checkbox"/>
Closeness of the hydraulic system.....	<input type="checkbox"/>	<input type="checkbox"/>	<input type="checkbox"/>
Condition hydraulic hoses.....	<input type="checkbox"/>	<input type="checkbox"/>	<input type="checkbox"/>
Function test with vehicle.....	<input type="checkbox"/>	<input type="checkbox"/>	<input type="checkbox"/>
Function flabby switch	<input type="checkbox"/>	<input type="checkbox"/>	<input type="checkbox"/>
Function CE-STOP.....	<input type="checkbox"/>	<input type="checkbox"/>	<input type="checkbox"/>
Function/condition ratchets.....	<input type="checkbox"/>	<input type="checkbox"/>	<input type="checkbox"/>
Function/condition pulleys.....	<input type="checkbox"/>	<input type="checkbox"/>	<input type="checkbox"/>
Function/condition slide-guidance.....	<input type="checkbox"/>	<input type="checkbox"/>	<input type="checkbox"/>
Condition plugs.....	<input type="checkbox"/>	<input type="checkbox"/>	<input type="checkbox"/>

(mark here applicable, in case of verification mark in addition to the first mark!)

Security check carried out:.....

Carried out the company:.....

Name, address of the competent:.....

Result of the Check:

Initiation not permitted, verification necessary

Initiation possible, repair failures

until.....

No failings, Initiation possible

.....
signature of the expert

.....
signature of the operator

If failures must be repaired:

Failures repaired at:

.....
signature of the operator

(Use another form for verification!)

Regular security check



Filling out and leave in this manual

Serial-no.: _____

kind of check	all right	defect missing	verification	remark
Type plate.....	<input type="checkbox"/>	<input type="checkbox"/>	<input type="checkbox"/>
Short operating instruction.....	<input type="checkbox"/>	<input type="checkbox"/>	<input type="checkbox"/>
Warning designation.....	<input type="checkbox"/>	<input type="checkbox"/>	<input type="checkbox"/>
Sticker max. capacity.....	<input type="checkbox"/>	<input type="checkbox"/>	<input type="checkbox"/>
Designation lifting/lowering.....	<input type="checkbox"/>	<input type="checkbox"/>	<input type="checkbox"/>
Detailed operating instruction.....	<input type="checkbox"/>	<input type="checkbox"/>	<input type="checkbox"/>
Function key switch.....	<input type="checkbox"/>	<input type="checkbox"/>	<input type="checkbox"/>
Condition bolts and bearings.....	<input type="checkbox"/>	<input type="checkbox"/>	<input type="checkbox"/>
Function limit switch.....	<input type="checkbox"/>	<input type="checkbox"/>	<input type="checkbox"/>
Condition/Function Ramps.....	<input type="checkbox"/>	<input type="checkbox"/>	<input type="checkbox"/>
Condition automotive lift.....	<input type="checkbox"/>	<input type="checkbox"/>	<input type="checkbox"/>
Securing of bolts.....	<input type="checkbox"/>	<input type="checkbox"/>	<input type="checkbox"/>
Condition welding.....	<input type="checkbox"/>	<input type="checkbox"/>	<input type="checkbox"/>
Function override switch.....	<input type="checkbox"/>	<input type="checkbox"/>	<input type="checkbox"/>
Construction (deformation, cracking)	<input type="checkbox"/>	<input type="checkbox"/>	<input type="checkbox"/>
Torque of the dowels	<input type="checkbox"/>	<input type="checkbox"/>	<input type="checkbox"/>
Fixed seat of the screws.....	<input type="checkbox"/>	<input type="checkbox"/>	<input type="checkbox"/>
Condition operating unit.....	<input type="checkbox"/>	<input type="checkbox"/>	<input type="checkbox"/>
Condition surface piston rod	<input type="checkbox"/>	<input type="checkbox"/>	<input type="checkbox"/>
Condition coverings.....	<input type="checkbox"/>	<input type="checkbox"/>	<input type="checkbox"/>
Condition electrical wires	<input type="checkbox"/>	<input type="checkbox"/>	<input type="checkbox"/>
Level of hydraulic oil	<input type="checkbox"/>	<input type="checkbox"/>	<input type="checkbox"/>
Closeness of the hydraulic system.....	<input type="checkbox"/>	<input type="checkbox"/>	<input type="checkbox"/>
Condition hydraulic hoses.....	<input type="checkbox"/>	<input type="checkbox"/>	<input type="checkbox"/>
Function test with vehicle.....	<input type="checkbox"/>	<input type="checkbox"/>	<input type="checkbox"/>
Function flabby switch	<input type="checkbox"/>	<input type="checkbox"/>	<input type="checkbox"/>
Function CE-STOP.....	<input type="checkbox"/>	<input type="checkbox"/>	<input type="checkbox"/>
Function/condition ratchets.....	<input type="checkbox"/>	<input type="checkbox"/>	<input type="checkbox"/>
Function/condition pulleys.....	<input type="checkbox"/>	<input type="checkbox"/>	<input type="checkbox"/>
Function/condition slide-guidance.....	<input type="checkbox"/>	<input type="checkbox"/>	<input type="checkbox"/>
Condition plugs.....	<input type="checkbox"/>	<input type="checkbox"/>	<input type="checkbox"/>

(mark here applicable, in case of verification mark in addition to the first mark!)

Security check carried out:.....

Carried out the company:.....

Name, address of the competent:.....

Result of the Check:

Initiation not permitted, verification necessary

Initiation possible, repair failures

until.....

No failings, Initiation possible

.....
signature of the expert

.....
signature of the operator

If failures must be repaired:

Failures repaired at:

.....
signature of the operator

(Use another form for verification!)

Regular security check



Filling out and leave in this manual

Serial-no.: _____

kind of check	all right	defect missing	verification	remark
Type plate.....	<input type="checkbox"/>	<input type="checkbox"/>	<input type="checkbox"/>
Short operating instruction.....	<input type="checkbox"/>	<input type="checkbox"/>	<input type="checkbox"/>
Warning designation.....	<input type="checkbox"/>	<input type="checkbox"/>	<input type="checkbox"/>
Sticker max. capacity.....	<input type="checkbox"/>	<input type="checkbox"/>	<input type="checkbox"/>
Designation lifting/lowering.....	<input type="checkbox"/>	<input type="checkbox"/>	<input type="checkbox"/>
Detailed operating instruction.....	<input type="checkbox"/>	<input type="checkbox"/>	<input type="checkbox"/>
Function key switch.....	<input type="checkbox"/>	<input type="checkbox"/>	<input type="checkbox"/>
Condition bolts and bearings.....	<input type="checkbox"/>	<input type="checkbox"/>	<input type="checkbox"/>
Function limit switch.....	<input type="checkbox"/>	<input type="checkbox"/>	<input type="checkbox"/>
Condition/Function Ramps.....	<input type="checkbox"/>	<input type="checkbox"/>	<input type="checkbox"/>
Condition automotive lift.....	<input type="checkbox"/>	<input type="checkbox"/>	<input type="checkbox"/>
Securing of bolts.....	<input type="checkbox"/>	<input type="checkbox"/>	<input type="checkbox"/>
Condition welding.....	<input type="checkbox"/>	<input type="checkbox"/>	<input type="checkbox"/>
Function override switch.....	<input type="checkbox"/>	<input type="checkbox"/>	<input type="checkbox"/>
Construction (deformation, cracking)	<input type="checkbox"/>	<input type="checkbox"/>	<input type="checkbox"/>
Torque of the dowels	<input type="checkbox"/>	<input type="checkbox"/>	<input type="checkbox"/>
Fixed seat of the screws.....	<input type="checkbox"/>	<input type="checkbox"/>	<input type="checkbox"/>
Condition operating unit.....	<input type="checkbox"/>	<input type="checkbox"/>	<input type="checkbox"/>
Condition surface piston rod	<input type="checkbox"/>	<input type="checkbox"/>	<input type="checkbox"/>
Condition coverings.....	<input type="checkbox"/>	<input type="checkbox"/>	<input type="checkbox"/>
Condition electrical wires	<input type="checkbox"/>	<input type="checkbox"/>	<input type="checkbox"/>
Level of hydraulic oil	<input type="checkbox"/>	<input type="checkbox"/>	<input type="checkbox"/>
Closeness of the hydraulic system.....	<input type="checkbox"/>	<input type="checkbox"/>	<input type="checkbox"/>
Condition hydraulic hoses.....	<input type="checkbox"/>	<input type="checkbox"/>	<input type="checkbox"/>
Function test with vehicle.....	<input type="checkbox"/>	<input type="checkbox"/>	<input type="checkbox"/>
Function flabby switch	<input type="checkbox"/>	<input type="checkbox"/>	<input type="checkbox"/>
Function CE-STOP.....	<input type="checkbox"/>	<input type="checkbox"/>	<input type="checkbox"/>
Function/condition ratchets.....	<input type="checkbox"/>	<input type="checkbox"/>	<input type="checkbox"/>
Function/condition pulleys.....	<input type="checkbox"/>	<input type="checkbox"/>	<input type="checkbox"/>
Function/condition slide-guidance.....	<input type="checkbox"/>	<input type="checkbox"/>	<input type="checkbox"/>
Condition plugs.....	<input type="checkbox"/>	<input type="checkbox"/>	<input type="checkbox"/>

(mark here applicable, in case of verification mark in addition to the first mark!)

Security check carried out:.....

Carried out the company:.....

Name, address of the competent:.....

Result of the Check:

Initiation not permitted, verification necessary

Initiation possible, repair failures

until.....

No failings, Initiation possible

.....
signature of the expert

.....
signature of the operator

If failures must be repaired:

Failures repaired at:

.....
signature of the operator

(Use another form for verification!)

Regular security check



Filling out and leave in this manual

Serial-no.: _____

kind of check	all right	defect missing	verification	remark
Type plate.....	<input type="checkbox"/>	<input type="checkbox"/>	<input type="checkbox"/>
Short operating instruction.....	<input type="checkbox"/>	<input type="checkbox"/>	<input type="checkbox"/>
Warning designation.....	<input type="checkbox"/>	<input type="checkbox"/>	<input type="checkbox"/>
Sticker max. capacity.....	<input type="checkbox"/>	<input type="checkbox"/>	<input type="checkbox"/>
Designation lifting/lowering.....	<input type="checkbox"/>	<input type="checkbox"/>	<input type="checkbox"/>
Detailed operating instruction.....	<input type="checkbox"/>	<input type="checkbox"/>	<input type="checkbox"/>
Function key switch.....	<input type="checkbox"/>	<input type="checkbox"/>	<input type="checkbox"/>
Condition bolts and bearings.....	<input type="checkbox"/>	<input type="checkbox"/>	<input type="checkbox"/>
Function limit switch.....	<input type="checkbox"/>	<input type="checkbox"/>	<input type="checkbox"/>
Condition/Function Ramps.....	<input type="checkbox"/>	<input type="checkbox"/>	<input type="checkbox"/>
Condition automotive lift.....	<input type="checkbox"/>	<input type="checkbox"/>	<input type="checkbox"/>
Securing of bolts.....	<input type="checkbox"/>	<input type="checkbox"/>	<input type="checkbox"/>
Condition welding.....	<input type="checkbox"/>	<input type="checkbox"/>	<input type="checkbox"/>
Function override switch.....	<input type="checkbox"/>	<input type="checkbox"/>	<input type="checkbox"/>
Construction (deformation, cracking)	<input type="checkbox"/>	<input type="checkbox"/>	<input type="checkbox"/>
Torque of the dowels	<input type="checkbox"/>	<input type="checkbox"/>	<input type="checkbox"/>
Fixed seat of the screws.....	<input type="checkbox"/>	<input type="checkbox"/>	<input type="checkbox"/>
Condition operating unit.....	<input type="checkbox"/>	<input type="checkbox"/>	<input type="checkbox"/>
Condition surface piston rod	<input type="checkbox"/>	<input type="checkbox"/>	<input type="checkbox"/>
Condition coverings.....	<input type="checkbox"/>	<input type="checkbox"/>	<input type="checkbox"/>
Condition electrical wires	<input type="checkbox"/>	<input type="checkbox"/>	<input type="checkbox"/>
Level of hydraulic oil	<input type="checkbox"/>	<input type="checkbox"/>	<input type="checkbox"/>
Closeness of the hydraulic system.....	<input type="checkbox"/>	<input type="checkbox"/>	<input type="checkbox"/>
Condition hydraulic hoses.....	<input type="checkbox"/>	<input type="checkbox"/>	<input type="checkbox"/>
Function test with vehicle.....	<input type="checkbox"/>	<input type="checkbox"/>	<input type="checkbox"/>
Function flabby switch	<input type="checkbox"/>	<input type="checkbox"/>	<input type="checkbox"/>
Function CE-STOP.....	<input type="checkbox"/>	<input type="checkbox"/>	<input type="checkbox"/>
Function/condition ratchets.....	<input type="checkbox"/>	<input type="checkbox"/>	<input type="checkbox"/>
Function/condition pulleys.....	<input type="checkbox"/>	<input type="checkbox"/>	<input type="checkbox"/>
Function/condition slide-guidance.....	<input type="checkbox"/>	<input type="checkbox"/>	<input type="checkbox"/>
Condition plugs.....	<input type="checkbox"/>	<input type="checkbox"/>	<input type="checkbox"/>

(mark here applicable, in case of verification mark in addition to the first mark!)

Security check carried out:.....

Carried out the company:.....

Name, address of the competent:.....

Result of the Check:

Initiation not permitted, verification necessary

Initiation possible, repair failures

until.....

No failings, Initiation possible

.....
signature of the expert

.....
signature of the operator

If failures must be repaired:

Failures repaired at:

.....
signature of the operator

(Use another form for verification!)

Regular security check



Filling out and leave in this manual

Serial-no.: _____

kind of check	all right	defect missing	verification	remark
Type plate.....	<input type="checkbox"/>	<input type="checkbox"/>	<input type="checkbox"/>
Short operating instruction.....	<input type="checkbox"/>	<input type="checkbox"/>	<input type="checkbox"/>
Warning designation.....	<input type="checkbox"/>	<input type="checkbox"/>	<input type="checkbox"/>
Sticker max. capacity.....	<input type="checkbox"/>	<input type="checkbox"/>	<input type="checkbox"/>
Designation lifting/lowering.....	<input type="checkbox"/>	<input type="checkbox"/>	<input type="checkbox"/>
Detailed operating instruction.....	<input type="checkbox"/>	<input type="checkbox"/>	<input type="checkbox"/>
Function key switch.....	<input type="checkbox"/>	<input type="checkbox"/>	<input type="checkbox"/>
Condition bolts and bearings.....	<input type="checkbox"/>	<input type="checkbox"/>	<input type="checkbox"/>
Function limit switch.....	<input type="checkbox"/>	<input type="checkbox"/>	<input type="checkbox"/>
Condition/Function Ramps.....	<input type="checkbox"/>	<input type="checkbox"/>	<input type="checkbox"/>
Condition automotive lift.....	<input type="checkbox"/>	<input type="checkbox"/>	<input type="checkbox"/>
Securing of bolts.....	<input type="checkbox"/>	<input type="checkbox"/>	<input type="checkbox"/>
Condition welding.....	<input type="checkbox"/>	<input type="checkbox"/>	<input type="checkbox"/>
Function override switch.....	<input type="checkbox"/>	<input type="checkbox"/>	<input type="checkbox"/>
Construction (deformation, cracking)	<input type="checkbox"/>	<input type="checkbox"/>	<input type="checkbox"/>
Torque of the dowels	<input type="checkbox"/>	<input type="checkbox"/>	<input type="checkbox"/>
Fixed seat of the screws.....	<input type="checkbox"/>	<input type="checkbox"/>	<input type="checkbox"/>
Condition operating unit.....	<input type="checkbox"/>	<input type="checkbox"/>	<input type="checkbox"/>
Condition surface piston rod	<input type="checkbox"/>	<input type="checkbox"/>	<input type="checkbox"/>
Condition coverings.....	<input type="checkbox"/>	<input type="checkbox"/>	<input type="checkbox"/>
Condition electrical wires	<input type="checkbox"/>	<input type="checkbox"/>	<input type="checkbox"/>
Level of hydraulic oil	<input type="checkbox"/>	<input type="checkbox"/>	<input type="checkbox"/>
Closeness of the hydraulic system.....	<input type="checkbox"/>	<input type="checkbox"/>	<input type="checkbox"/>
Condition hydraulic hoses.....	<input type="checkbox"/>	<input type="checkbox"/>	<input type="checkbox"/>
Function test with vehicle.....	<input type="checkbox"/>	<input type="checkbox"/>	<input type="checkbox"/>
Function flabby switch	<input type="checkbox"/>	<input type="checkbox"/>	<input type="checkbox"/>
Function CE-STOP.....	<input type="checkbox"/>	<input type="checkbox"/>	<input type="checkbox"/>
Function/condition ratchets.....	<input type="checkbox"/>	<input type="checkbox"/>	<input type="checkbox"/>
Function/condition pulleys.....	<input type="checkbox"/>	<input type="checkbox"/>	<input type="checkbox"/>
Function/condition slide-guidance.....	<input type="checkbox"/>	<input type="checkbox"/>	<input type="checkbox"/>
Condition plugs.....	<input type="checkbox"/>	<input type="checkbox"/>	<input type="checkbox"/>

(mark here applicable, in case of verification mark in addition to the first mark!)

Security check carried out:.....

Carried out the company:.....

Name, address of the competent:.....

Result of the Check:

Initiation not permitted, verification necessary

Initiation possible, repair failures

until.....

No failings, Initiation possible

.....
signature of the expert

.....
signature of the operator

If failures must be repaired:

Failures repaired at:

.....
signature of the operator

(Use another form for verification!)

Regular security check



Filling out and leave in this manual

Serial-no.: _____

kind of check	all right	defect missing	verification	remark
Type plate.....	<input type="checkbox"/>	<input type="checkbox"/>	<input type="checkbox"/>
Short operating instruction.....	<input type="checkbox"/>	<input type="checkbox"/>	<input type="checkbox"/>
Warning designation.....	<input type="checkbox"/>	<input type="checkbox"/>	<input type="checkbox"/>
Sticker max. capacity.....	<input type="checkbox"/>	<input type="checkbox"/>	<input type="checkbox"/>
Designation lifting/lowering.....	<input type="checkbox"/>	<input type="checkbox"/>	<input type="checkbox"/>
Detailed operating instruction.....	<input type="checkbox"/>	<input type="checkbox"/>	<input type="checkbox"/>
Function key switch.....	<input type="checkbox"/>	<input type="checkbox"/>	<input type="checkbox"/>
Condition bolts and bearings.....	<input type="checkbox"/>	<input type="checkbox"/>	<input type="checkbox"/>
Function limit switch.....	<input type="checkbox"/>	<input type="checkbox"/>	<input type="checkbox"/>
Condition/Function Ramps.....	<input type="checkbox"/>	<input type="checkbox"/>	<input type="checkbox"/>
Condition automotive lift.....	<input type="checkbox"/>	<input type="checkbox"/>	<input type="checkbox"/>
Securing of bolts.....	<input type="checkbox"/>	<input type="checkbox"/>	<input type="checkbox"/>
Condition welding.....	<input type="checkbox"/>	<input type="checkbox"/>	<input type="checkbox"/>
Function override switch.....	<input type="checkbox"/>	<input type="checkbox"/>	<input type="checkbox"/>
Construction (deformation, cracking)	<input type="checkbox"/>	<input type="checkbox"/>	<input type="checkbox"/>
Torque of the dowels	<input type="checkbox"/>	<input type="checkbox"/>	<input type="checkbox"/>
Fixed seat of the screws.....	<input type="checkbox"/>	<input type="checkbox"/>	<input type="checkbox"/>
Condition operating unit.....	<input type="checkbox"/>	<input type="checkbox"/>	<input type="checkbox"/>
Condition surface piston rod	<input type="checkbox"/>	<input type="checkbox"/>	<input type="checkbox"/>
Condition coverings.....	<input type="checkbox"/>	<input type="checkbox"/>	<input type="checkbox"/>
Condition electrical wires	<input type="checkbox"/>	<input type="checkbox"/>	<input type="checkbox"/>
Level of hydraulic oil	<input type="checkbox"/>	<input type="checkbox"/>	<input type="checkbox"/>
Closeness of the hydraulic system.....	<input type="checkbox"/>	<input type="checkbox"/>	<input type="checkbox"/>
Condition hydraulic hoses.....	<input type="checkbox"/>	<input type="checkbox"/>	<input type="checkbox"/>
Function test with vehicle.....	<input type="checkbox"/>	<input type="checkbox"/>	<input type="checkbox"/>
Function flabby switch	<input type="checkbox"/>	<input type="checkbox"/>	<input type="checkbox"/>
Function CE-STOP.....	<input type="checkbox"/>	<input type="checkbox"/>	<input type="checkbox"/>
Function/condition ratchets.....	<input type="checkbox"/>	<input type="checkbox"/>	<input type="checkbox"/>
Function/condition pulleys.....	<input type="checkbox"/>	<input type="checkbox"/>	<input type="checkbox"/>
Function/condition slide-guidance.....	<input type="checkbox"/>	<input type="checkbox"/>	<input type="checkbox"/>
Condition plugs.....	<input type="checkbox"/>	<input type="checkbox"/>	<input type="checkbox"/>

(mark here applicable, in case of verification mark in addition to the first mark!)

Security check carried out:.....

Carried out the company:.....

Name, address of the competent:.....

Result of the Check:

Initiation not permitted, verification necessary

Initiation possible, repair failures

until.....

No failings, Initiation possible

.....
signature of the expert

.....
signature of the operator

If failures must be repaired:

Failures repaired at:

.....
signature of the operator

(Use another form for verification!)

Regular security check



Filling out and leave in this manual

Serial-no.: _____

kind of check	all right	defect missing	verification	remark
Type plate.....	<input type="checkbox"/>	<input type="checkbox"/>	<input type="checkbox"/>
Short operating instruction.....	<input type="checkbox"/>	<input type="checkbox"/>	<input type="checkbox"/>
Warning designation.....	<input type="checkbox"/>	<input type="checkbox"/>	<input type="checkbox"/>
Sticker max. capacity.....	<input type="checkbox"/>	<input type="checkbox"/>	<input type="checkbox"/>
Designation lifting/lowering.....	<input type="checkbox"/>	<input type="checkbox"/>	<input type="checkbox"/>
Detailed operating instruction.....	<input type="checkbox"/>	<input type="checkbox"/>	<input type="checkbox"/>
Function key switch.....	<input type="checkbox"/>	<input type="checkbox"/>	<input type="checkbox"/>
Condition bolts and bearings.....	<input type="checkbox"/>	<input type="checkbox"/>	<input type="checkbox"/>
Function limit switch.....	<input type="checkbox"/>	<input type="checkbox"/>	<input type="checkbox"/>
Condition/Function Ramps.....	<input type="checkbox"/>	<input type="checkbox"/>	<input type="checkbox"/>
Condition automotive lift.....	<input type="checkbox"/>	<input type="checkbox"/>	<input type="checkbox"/>
Securing of bolts.....	<input type="checkbox"/>	<input type="checkbox"/>	<input type="checkbox"/>
Condition welding.....	<input type="checkbox"/>	<input type="checkbox"/>	<input type="checkbox"/>
Function override switch.....	<input type="checkbox"/>	<input type="checkbox"/>	<input type="checkbox"/>
Construction (deformation, cracking)	<input type="checkbox"/>	<input type="checkbox"/>	<input type="checkbox"/>
Torque of the dowels	<input type="checkbox"/>	<input type="checkbox"/>	<input type="checkbox"/>
Fixed seat of the screws.....	<input type="checkbox"/>	<input type="checkbox"/>	<input type="checkbox"/>
Condition operating unit.....	<input type="checkbox"/>	<input type="checkbox"/>	<input type="checkbox"/>
Condition surface piston rod	<input type="checkbox"/>	<input type="checkbox"/>	<input type="checkbox"/>
Condition coverings.....	<input type="checkbox"/>	<input type="checkbox"/>	<input type="checkbox"/>
Condition electrical wires	<input type="checkbox"/>	<input type="checkbox"/>	<input type="checkbox"/>
Level of hydraulic oil	<input type="checkbox"/>	<input type="checkbox"/>	<input type="checkbox"/>
Closeness of the hydraulic system.....	<input type="checkbox"/>	<input type="checkbox"/>	<input type="checkbox"/>
Condition hydraulic hoses.....	<input type="checkbox"/>	<input type="checkbox"/>	<input type="checkbox"/>
Function test with vehicle.....	<input type="checkbox"/>	<input type="checkbox"/>	<input type="checkbox"/>
Function flabby switch	<input type="checkbox"/>	<input type="checkbox"/>	<input type="checkbox"/>
Function CE-STOP.....	<input type="checkbox"/>	<input type="checkbox"/>	<input type="checkbox"/>
Function/condition ratchets.....	<input type="checkbox"/>	<input type="checkbox"/>	<input type="checkbox"/>
Function/condition pulleys.....	<input type="checkbox"/>	<input type="checkbox"/>	<input type="checkbox"/>
Function/condition slide-guidance.....	<input type="checkbox"/>	<input type="checkbox"/>	<input type="checkbox"/>
Condition plugs.....	<input type="checkbox"/>	<input type="checkbox"/>	<input type="checkbox"/>

(mark here applicable, in case of verification mark in addition to the first mark!)

Security check carried out:.....

Carried out the company:.....

Name, address of the competent:.....

Result of the Check:

Initiation not permitted, verification necessary

Initiation possible, repair failures

until.....

No failings, Initiation possible

.....
signature of the expert

.....
signature of the operator

If failures must be repaired:

Failures repaired at:

.....
signature of the operator

(Use another form for verification!)

Regular security check



Filling out and leave in this manual

Serial-no.: _____

kind of check	all right	defect missing	verification	remark
Type plate.....	<input type="checkbox"/>	<input type="checkbox"/>	<input type="checkbox"/>
Short operating instruction.....	<input type="checkbox"/>	<input type="checkbox"/>	<input type="checkbox"/>
Warning designation.....	<input type="checkbox"/>	<input type="checkbox"/>	<input type="checkbox"/>
Sticker max. capacity.....	<input type="checkbox"/>	<input type="checkbox"/>	<input type="checkbox"/>
Designation lifting/lowering.....	<input type="checkbox"/>	<input type="checkbox"/>	<input type="checkbox"/>
Detailed operating instruction.....	<input type="checkbox"/>	<input type="checkbox"/>	<input type="checkbox"/>
Function key switch.....	<input type="checkbox"/>	<input type="checkbox"/>	<input type="checkbox"/>
Condition bolts and bearings.....	<input type="checkbox"/>	<input type="checkbox"/>	<input type="checkbox"/>
Function limit switch.....	<input type="checkbox"/>	<input type="checkbox"/>	<input type="checkbox"/>
Condition/Function Ramps.....	<input type="checkbox"/>	<input type="checkbox"/>	<input type="checkbox"/>
Condition automotive lift.....	<input type="checkbox"/>	<input type="checkbox"/>	<input type="checkbox"/>
Securing of bolts.....	<input type="checkbox"/>	<input type="checkbox"/>	<input type="checkbox"/>
Condition welding.....	<input type="checkbox"/>	<input type="checkbox"/>	<input type="checkbox"/>
Function override switch.....	<input type="checkbox"/>	<input type="checkbox"/>	<input type="checkbox"/>
Construction (deformation, cracking)	<input type="checkbox"/>	<input type="checkbox"/>	<input type="checkbox"/>
Torque of the dowels	<input type="checkbox"/>	<input type="checkbox"/>	<input type="checkbox"/>
Fixed seat of the screws.....	<input type="checkbox"/>	<input type="checkbox"/>	<input type="checkbox"/>
Condition operating unit.....	<input type="checkbox"/>	<input type="checkbox"/>	<input type="checkbox"/>
Condition surface piston rod	<input type="checkbox"/>	<input type="checkbox"/>	<input type="checkbox"/>
Condition coverings.....	<input type="checkbox"/>	<input type="checkbox"/>	<input type="checkbox"/>
Condition electrical wires	<input type="checkbox"/>	<input type="checkbox"/>	<input type="checkbox"/>
Level of hydraulic oil	<input type="checkbox"/>	<input type="checkbox"/>	<input type="checkbox"/>
Closeness of the hydraulic system.....	<input type="checkbox"/>	<input type="checkbox"/>	<input type="checkbox"/>
Condition hydraulic hoses.....	<input type="checkbox"/>	<input type="checkbox"/>	<input type="checkbox"/>
Function test with vehicle.....	<input type="checkbox"/>	<input type="checkbox"/>	<input type="checkbox"/>
Function flabby switch	<input type="checkbox"/>	<input type="checkbox"/>	<input type="checkbox"/>
Function CE-STOP.....	<input type="checkbox"/>	<input type="checkbox"/>	<input type="checkbox"/>
Function/condition ratchets.....	<input type="checkbox"/>	<input type="checkbox"/>	<input type="checkbox"/>
Function/condition pulleys.....	<input type="checkbox"/>	<input type="checkbox"/>	<input type="checkbox"/>
Function/condition slide-guidance.....	<input type="checkbox"/>	<input type="checkbox"/>	<input type="checkbox"/>
Condition plugs.....	<input type="checkbox"/>	<input type="checkbox"/>	<input type="checkbox"/>

(mark here applicable, in case of verification mark in addition to the first mark!)

Security check carried out:.....

Carried out the company:.....

Name, address of the competent:.....

Result of the Check:

Initiation not permitted, verification necessary

Initiation possible, repair failures

until.....

No failings, Initiation possible

.....
signature of the expert

.....
signature of the operator

If failures must be repaired:

Failures repaired at:

.....
signature of the operator

(Use another form for verification!)

Extraordinary security check



Filling out and leave in this manual

Serial-no.: _____

kind of check	all right	defect missing	verification	remark
Type plate.....	<input type="checkbox"/>	<input type="checkbox"/>	<input type="checkbox"/>
Short operating instruction.....	<input type="checkbox"/>	<input type="checkbox"/>	<input type="checkbox"/>
Warning designation.....	<input type="checkbox"/>	<input type="checkbox"/>	<input type="checkbox"/>
Sticker max. capacity.....	<input type="checkbox"/>	<input type="checkbox"/>	<input type="checkbox"/>
Designation lifting/lowering.....	<input type="checkbox"/>	<input type="checkbox"/>	<input type="checkbox"/>
Detailed operating instruction.....	<input type="checkbox"/>	<input type="checkbox"/>	<input type="checkbox"/>
Function key switch.....	<input type="checkbox"/>	<input type="checkbox"/>	<input type="checkbox"/>
Condition bolts and bearings.....	<input type="checkbox"/>	<input type="checkbox"/>	<input type="checkbox"/>
Function limit switch.....	<input type="checkbox"/>	<input type="checkbox"/>	<input type="checkbox"/>
Condition/Function Ramps.....	<input type="checkbox"/>	<input type="checkbox"/>	<input type="checkbox"/>
Condition automotive lift.....	<input type="checkbox"/>	<input type="checkbox"/>	<input type="checkbox"/>
Securing of bolts.....	<input type="checkbox"/>	<input type="checkbox"/>	<input type="checkbox"/>
Condition welding.....	<input type="checkbox"/>	<input type="checkbox"/>	<input type="checkbox"/>
Function override switch.....	<input type="checkbox"/>	<input type="checkbox"/>	<input type="checkbox"/>
Construction (deformation, cracking)	<input type="checkbox"/>	<input type="checkbox"/>	<input type="checkbox"/>
Torque of the dowels	<input type="checkbox"/>	<input type="checkbox"/>	<input type="checkbox"/>
Fixed seat of the screws.....	<input type="checkbox"/>	<input type="checkbox"/>	<input type="checkbox"/>
Condition operating unit.....	<input type="checkbox"/>	<input type="checkbox"/>	<input type="checkbox"/>
Condition surface piston rod	<input type="checkbox"/>	<input type="checkbox"/>	<input type="checkbox"/>
Condition coverings.....	<input type="checkbox"/>	<input type="checkbox"/>	<input type="checkbox"/>
Condition electrical wires	<input type="checkbox"/>	<input type="checkbox"/>	<input type="checkbox"/>
Level of hydraulic oil	<input type="checkbox"/>	<input type="checkbox"/>	<input type="checkbox"/>
Closeness of the hydraulic system.....	<input type="checkbox"/>	<input type="checkbox"/>	<input type="checkbox"/>
Condition hydraulic hoses.....	<input type="checkbox"/>	<input type="checkbox"/>	<input type="checkbox"/>
Function test with vehicle.....	<input type="checkbox"/>	<input type="checkbox"/>	<input type="checkbox"/>
Function flabby switch	<input type="checkbox"/>	<input type="checkbox"/>	<input type="checkbox"/>
Function CE-STOP.....	<input type="checkbox"/>	<input type="checkbox"/>	<input type="checkbox"/>
Function/condition ratchets.....	<input type="checkbox"/>	<input type="checkbox"/>	<input type="checkbox"/>
Function/condition pulleys.....	<input type="checkbox"/>	<input type="checkbox"/>	<input type="checkbox"/>
Function/condition slide-guidance.....	<input type="checkbox"/>	<input type="checkbox"/>	<input type="checkbox"/>
Condition plugs.....	<input type="checkbox"/>	<input type="checkbox"/>	<input type="checkbox"/>

(mark here applicable, in case of verification mark in addition to the first mark!)

Security check carried out:.....

Carried out the company:.....

Name, address of the competent:.....

Result of the Check:

Initiation not permitted, verification necessary

Initiation possible, repair failures

until.....

No failings, Initiation possible

.....
signature of the expert

.....
signature of the operator

If failures must be repaired:

Failures repaired at:

.....
signature of the operator

(Use another form for verification!)